

# ASSEMBLY AND FINISHING INSTRUCTIONS

## COLLECTORS NO 42404

Chippendale  
Pier Mirror  
Circa 1750

The distinguishing feature between a pier mirror and a standard mirror was its overall length in comparison to its width. It was designed to be hung in the area between two long windows, an area which

often projected slightly into the room, that architecturally is known as a pier.

There is a fine distinction between a mirror and a looking glass and the difference lies in the type of material that is used for a reflective surface. The mirror could be of either metal or glass, while the looking glass was always glass. Prior to America having a relative plentiful supply of glass, this difference was an important selling point.

The outer shapes of these scrolled mirrors reflected the free flowing, undulating shapes particularly favored by Chippendale. He also tended to create asymmetrical designs while his American contemporaries leaned more towards designs that were symmetrical.

This mirror was framed in pine with a mahogany veneered surface. The reflecting surface was glass.



AUTHENTIC REPRODUCTIONS IN MINIATURE

The X-ACTO® House of Miniatures® Collectors Series of furniture and accessories have all been carefully researched by specialists through major museum and library collections to assure the highest quality of authenticity in reproduction. Details are extraordinarily accurate to satisfy the most discriminating miniaturist.

All wood parts are machined to assure accurate and precise acceptance of each piece by another.

For a complete catalog of the X-ACTO® HOUSE OF MINIATURES furniture line and accessories, write to:

X-ACTO® THE HOUSE OF MINIATURES Dept. KIT  
45-35 Van Dam Street  
Long Island City,  
New York 11101

Please include \$1.00 for postage and handling.

### TOOLS AND MATERIALS

A. The following tools will be helpful in constructing this kit:

1. One-inch Sander, X-ACTO No. 7041
2. X-ACTO Professional Finishing Kit (or equivalent, see note)

B. The following materials will be needed to construct this kit:

1. X-ACTO Tinted Glue (see note)
2. Waxed paper
3. Sandpaper - 220 and 280 grit
4. White glue (or equivalent)
5. Small Artist's Brush

**NOTE:** The X-ACTO tinted glue is matched to the finish used in the Professional Finishing Kit. This will produce the authentic finish of the period in which the original Furniture was produced. When not using X-ACTO glue follow manufacturer's directions.

### GLUING

- A. Glue should be applied in small amounts to surface being joined. When gluing dado joints apply glue to dado only.
- B. To ensure a tight fit, squeeze excess glue out of the joints. Hold glued parts together with clamps, rubber bands or weights on the parts.
- C. Wipe off excess glue promptly.
- D. Be sure a glued assembly has dried thoroughly before adding parts.

### FINISHING

The X-ACTO Professional Finishing Kit enables you to finish your furniture by the same process used by the professional furniture maker. The end result is what is important — there are easier methods, but none that will give the quality results that this process will. If you use a finish other than X-ACTO's, refer to the manufacturer's directions.

## INTRODUCTION

### BEFORE STARTING

Identify and account for each part by placing it on the Layout Sheet (make sure the correct layout sheet is used when working on multi-kit Instruction Sheets). Should any parts be missing, send a post card to:

X-ACTO/The House of Miniatures  
45-35 Van Dam Street  
Long Island City, N.Y. 11101

Please print Name, Address, Part Number (Number from Layout Sheet) and Kit Name and Number on card when ordering.

### SANDING

Before assembly, sand all the outer surfaces of individual parts with 220 grit sandpaper, or finer, sanded in the same direction as the wood grain until the surface is smooth. Take care not to round any edges or corners of the pieces. Finish sanding with 280 grit sandpaper.

### PRE-ASSEMBLY

- A. After sanding, check the proper location and fit of each part by assembling parts loosely, without gluing. Use the **DETAIL VIEWS** as a guide.
- B. All parts for X-ACTO kits are made on precision milling machines. When adjustments are required, sand to fit.

© X-ACTO, a unit of CBS, Inc., 1979

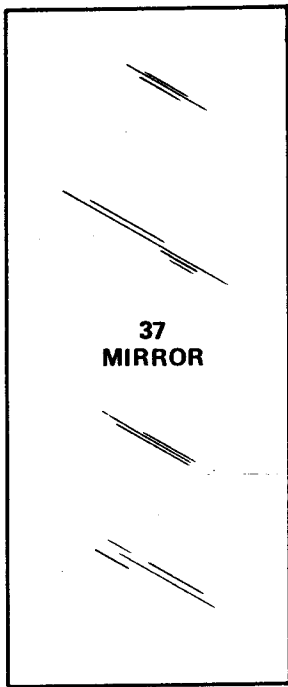

**37  
MIRROR**

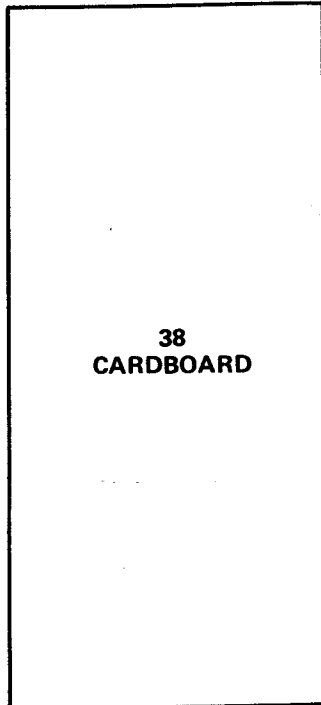

**38  
CARDBOARD**

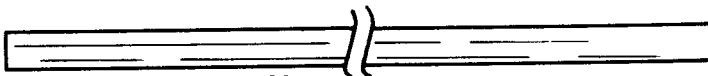

**30  
(4 REQ'D)**

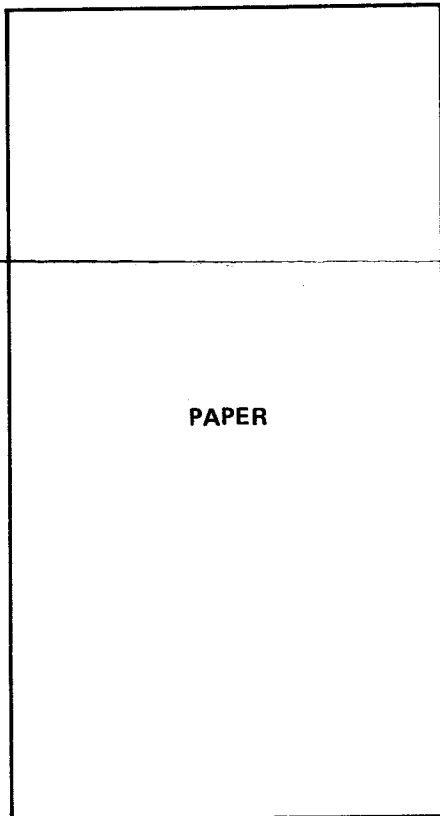

**PAPER**

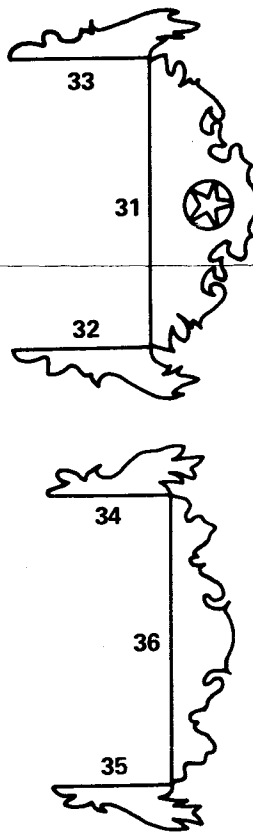

## Step 1

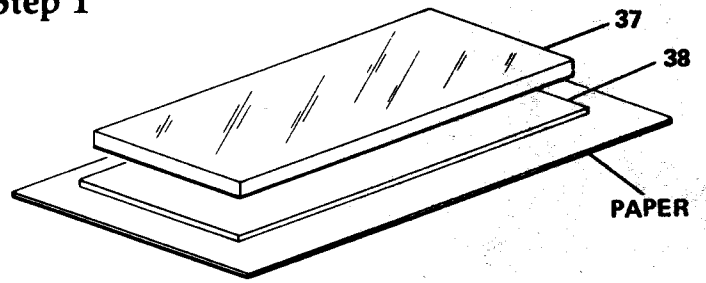

**PAPER**

A. Glue mirror (37) to backing (38). Trim backing to exact size of mirror.

B. Glue backing to a piece of plain white paper (not supplied) that is larger than backing. Do not trim.

## Step 2

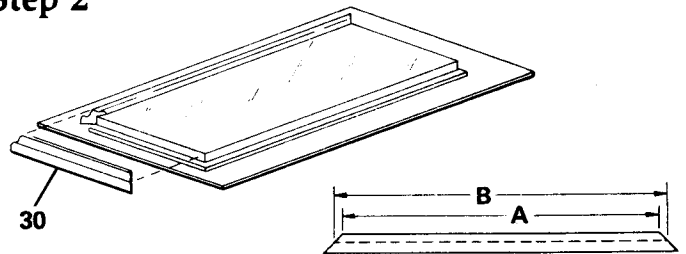

A. Frame mirror using picture frame molding (30). Miter corners at a 45° angle. Glue to backing and paper.

**NOTE:** Since the frame molding extends over the edge of the mirror, care must be taken when measuring the molding. On the mitering guide, "B" is the length of the mirror edge you are working on. "A" is the length of the inside edge that will rest on the mirror. "B" less 1/16" will equal "A" with this particular molding regardless of the length of "B".

is the length of the mirror edge you are working on. "A" is the length of the inside edge that will rest on the mirror. "B" less 1/16" will equal "A" with this particular molding regardless of the length of "B".

## Step 3

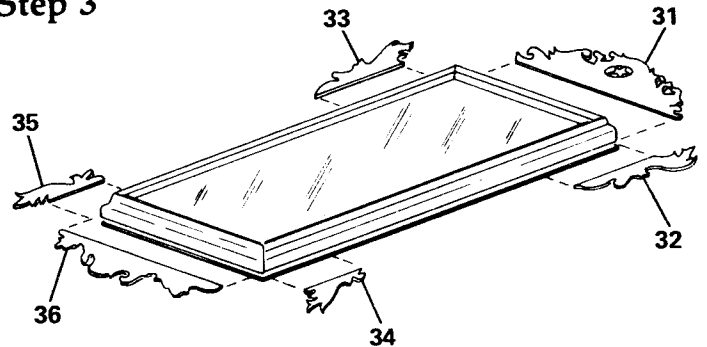

A. Once glue in Step 2 has set, trim paper backing so that you just have a slight reinforcing piece under the trim.

B. Glue on the scrolled frame

as shown. One side of these pieces is not as smooth as the other. In all cases the smooth side should face up. Trim is glued flush with back of mirror. Apply final finish.