

COLLECTORS NO. 41220 JAMES RIVER FIREPLACE

ASSEMBLY AND FINISHING INSTRUCTIONS



AUTHENTIC REPRODUCTIONS IN MINIATURE

The X-ACTO® House of Miniatures Collectors Series® of furniture and accessories have all been carefully researched by specialists through major museum and library collections to assure the highest quality of authenticity in reproduction. Details are extraordinarily accurate to satisfy the most discriminating miniaturist.

Every item in the line is an authentic reproduction in miniature of regular-size furniture created by master craftsmen during the Colonial period, precision scaled, one inch to one foot.

All wood parts are machined to assure accurate and precise acceptance of each piece by another.

The rooms illustrated have been completed using standard X-ACTO® HOUSE OF MINIATURES products. All individual components are available.

For a complete catalog of the X-ACTO® HOUSE OF MINIATURES furniture line and accessories, write to:

X-ACTO® THE HOUSE OF MINIATURES Dept. KIT
45-35 Van Dam Street
Long Island City, New York
11101

Please include \$2.00 for postage and handling.

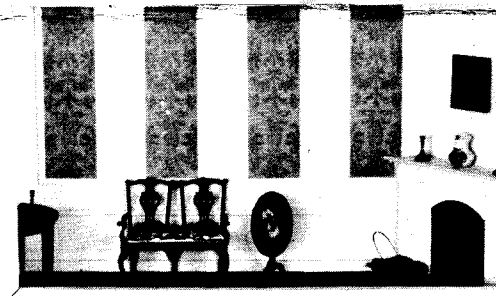
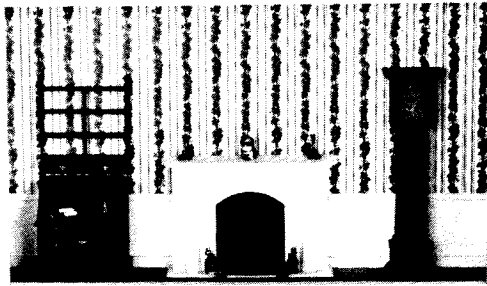

X-ACTO

© X-ACTO, a subsidiary of Hunt Mfg. Co., Philadelphia, Pa., 1977

www.TheHouseOfMiniatures.org

INTRODUCTION

BEFORE STARTING

Identify and account for each part by placing it on the Layout Sheet (make sure the correct layout sheet is used when working on multi-kit Instruction Sheets). Should any parts be missing, send a post card to:

X-ACTO/The House of Miniatures
45-35 Van Dam Street
Long Island City, N.Y. 11101

Please print Name, Address, Part Number (Number from Layout Sheet) and Kit Name and Number on card when ordering.

SANDING

NOTE: When using sandpaper, remember that the higher the grit number, the finer the finish.

A. One sanding method that has proved successful is the use of a sanding platform. Tape a sheet of sandpaper of the proper grit size to a hard flat surface such as a table top or wood block. Press down lightly and move the piece to be sanded in the same direction as the wood grain until the surface is smooth. Take care not to round any edges or corners of the pieces.

B. Before assembly, sand all the outer surfaces of individual parts with 220 grit sandpaper, or finer. Finish sanding with 400 grit sandpaper.

PRE-ASSEMBLY

A. After sanding, check the proper location and fit of each part by assembling parts loosely, without gluing. Use the **DETAIL VIEWS** as a guide.

B. All parts for X-ACTO kits are made on precision milling machines. When adjustments are required, sand or file to fit.

TOOLS AND MATERIALS

A. The following tools will be helpful in constructing this kit:

1. Knife, X-ACTO No. 1, with Blade, X-ACTO No. 11
2. Two-inch Sander, X-ACTO No. 7042
3. Large Clamp, X-ACTO No. 4004
4. Small Clamp, X-ACTO No. 4003

B. The following materials will be needed to construct this kit:

1. White Glue
2. Waxed paper
3. Sandpaper - 220 and 400 grit
4. High Quality Modeler's Paint

GLUING

A. Glue should be applied in small amounts to surface being joined. When gluing dado joints apply glue to dado only. On end cuts, it may be necessary to apply a second coat of glue before joining the parts.

B. To ensure a tight fit, squeeze excess glue out of the joints. Hold glued parts together with clamps, rubber bands or weights on the parts.

C. Wipe off excess glue promptly.

D. Be sure a glued assembly has dried thoroughly before adding parts.

MITERING

A. Mitering is the process of forming a joint by cutting two pieces of molding at a predetermined angle.

1. Inside Molding. This terminology refers to molding designed to dress off a recessed section of an assembly. Inside molding dimensions are given from farthest point to farthest point and shall be cut at 45° angles unless otherwise noted.

Example:

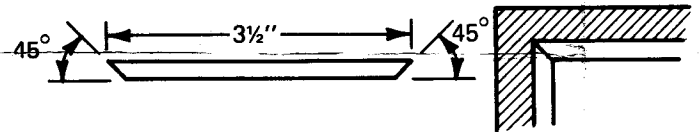

2. Outside Molding. This terminology refers to molding designed to dress off outside portions of a structure. Outside molding dimensions are given from inside point to inside point and shall be cut at 45° angles unless otherwise noted.

Example:

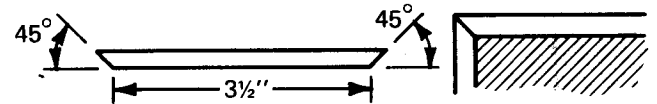

3. Miter Cut. To match two pieces of molding together by cutting the two pieces at a specified angle.

Example:

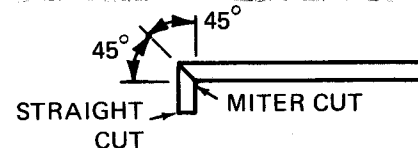

4. Straight Cut. To match two pieces together without the use of a mitered cut.

FINAL FINISHING

A. After assembly is completed and the glue has set, lightly sand all joint areas to remove excess glue, using 220 grit sandpaper or finer.

B. Paint with a high quality paint of your choice.

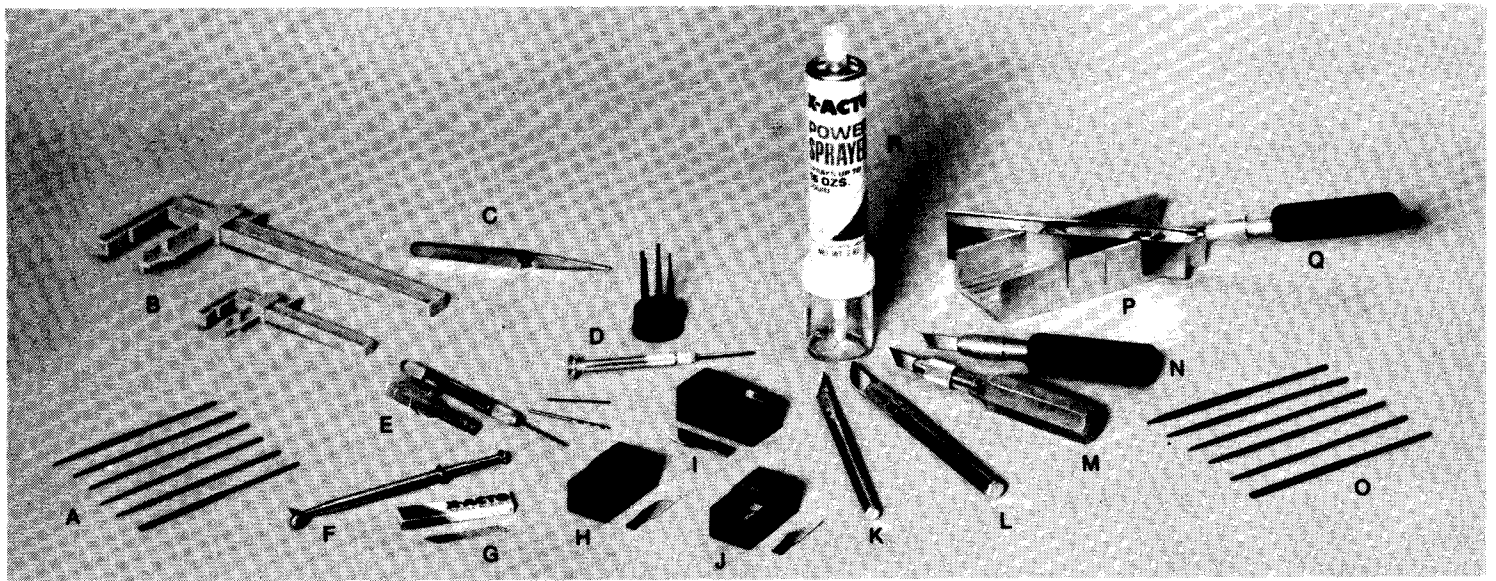

X-ACTO® precision tools make fine miniatures.

A. MINIATURE FILE SET

6 miniature needle files. 3 $\frac{1}{8}$ " long. For intricate filing. Vinyl storage pouch. No. 7365

B. PLASTIC CLAMPS

Light duty plastic clamps for delicate work. Notched jaw allows grip of round parts. Smooth face prevents damage to workpiece.

Small plastic clamp. 3 $\frac{1}{4}$ " opening with 1" throat depth.

2 per card: No. 7003

Large plastic clamp. 7 $\frac{1}{4}$ " opening with 2 $\frac{1}{8}$ " throat depth.

2 per card: No. 7004

C. SELF-CLOSING POINTED TWEEZER

Self-closing serrated points. Nickel-plated steel. 6 $\frac{1}{2}$ ". Carded: No. 7337

D. SCREWDRIVER WITH INTERCHANGEABLE BLADES

Aluminum handle and chuck and 5 steel screwdriver blades sizes .040" through .100". Notched shank for greater torque. Storage base. Carded: No. 7070

E. PIN VISE SET

Includes double-ended pin vise, pin vise bit guard and 3 assorted drill bits. Carded: No. 7144

F. PARTPICKER

For small hard-to-handle pieces. Smooth one-handed action. Carded: No. 7380

G. No. 13 BLADE

Precision saw cutting. 5 blades. Carded: No. 213

H. No. 10 BLADE

For fine general cutting, carving, correcting stencils. Safety dispenser of 10 blades. Carded: No. 410

I. No. 22 BLADE

General shaping, whittling, trimming, removing excess flashing. Safety dispenser of 10 blades. Carded: No. 422

J. No. 11 BLADE

Extremely sharp point for fine angle cutting and stripping. Safety dispenser of 10 blades. Carded: No. 411

K. No. 1 KNIFE

Aluminum handle 4 $\frac{7}{8}$ " long with No. 11 blade. Carded: No. 3201

L. No. 2 KNIFE

Aluminum handle 5" long with No. 22 blade. Carded: No. 3202

M. No. 6 KNIFE

Aluminum handle 4 $\frac{3}{4}$ " long with No. 24 blade. Carded: No. 3206

N. No. 5 KNIFE

Plastic handle with metal blade lock, 4 $\frac{1}{4}$ " long with No. 19 blade. Carded: No. 3205

O. MINIATURE NEEDLE RASPS

6 assorted rasps. For rough shaping of wood or plastic. 4 $\frac{3}{4}$ " long. Vinyl storage pouch. No. 7366

P. MITRE BOX

Aluminum 3 $\frac{1}{4}$ " x 1 $\frac{3}{4}$ " capacity. 6" long. With two 45° and one 90° cutting slots. Carded: No. 7533

Q. EXTRA-FINE RAZOR SAW

1 $\frac{1}{4}$ " deep with cutting edge 5 $\frac{1}{2}$ " long and 54 teeth per inch for extra fine precision. For use with No. 7533 mitre box. Carded: No. 7535

R. POWER SPRAYER

Push-button action sprays evenly. Includes a one ounce jar and propellant to spray on intricate or flat surfaces up to 16 ounces of liquid materials. Carded: No. 43561

MINIATURIST'S TOOL SET

Basic tools for assembling miniatures, models and working with small parts. 4 clamps, tweezer, pin vise with 3 bits, 2 sanders, screwdriver and No. 1 Knife in fitted tray. No. 43910

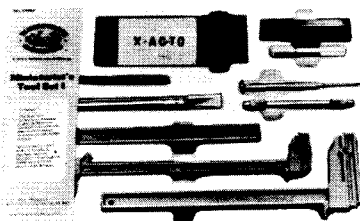

DELUXE MINIATURIST'S TOOL CHEST

Fitted wooden chest contains precision tools for assembling miniatures, models and working with small parts: razor saw blade, mitre box, 4 clamps, pin vise and 3 bits, Nos. 1 and 5 Knives, sanders and screwdriver. Boxed: No. 43911

Layout Sheet

KIT 41220

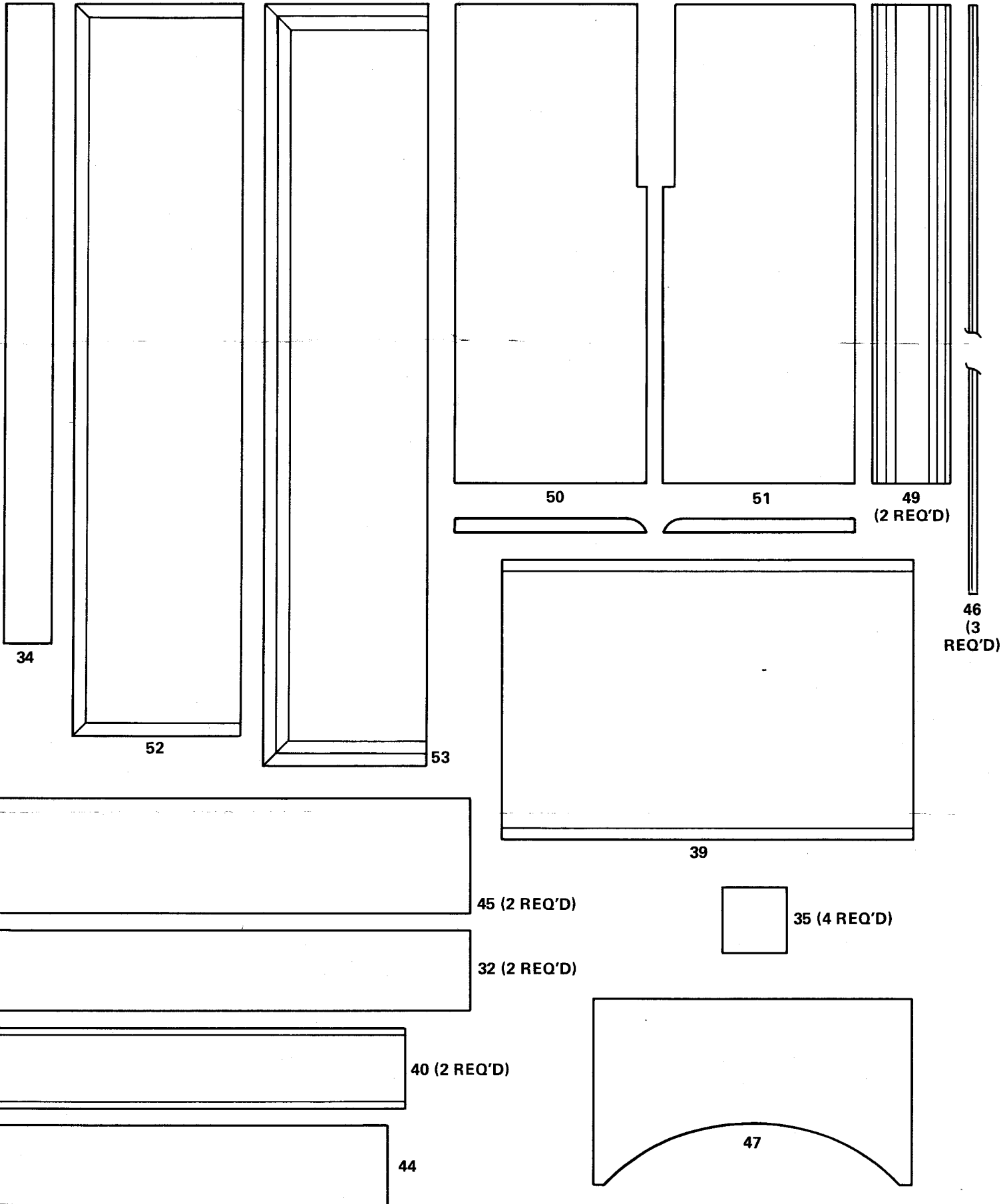

Detail Views

KIT 41220

Step 1

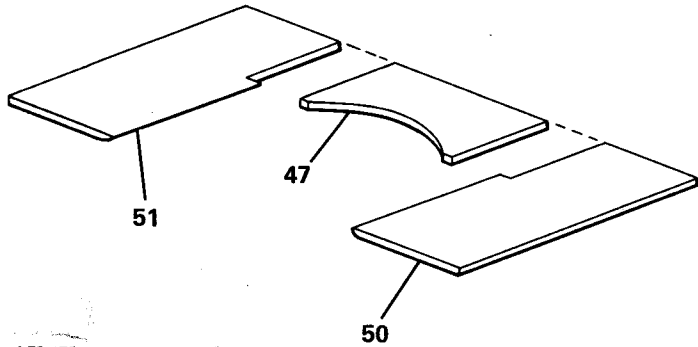

NOTE: Assemble front side down.

A. Cover flat surface with waxed paper and glue front center top (47) to front left side (51) and front right side (50).

Step 3

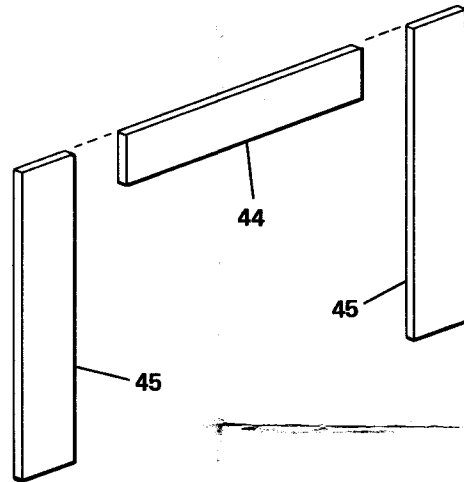

A. Glue frame sides (45) to frame top (44). Ensure top edges of frame are flush.

NOTE: Ensure top edges of frame are flush.

Step 2

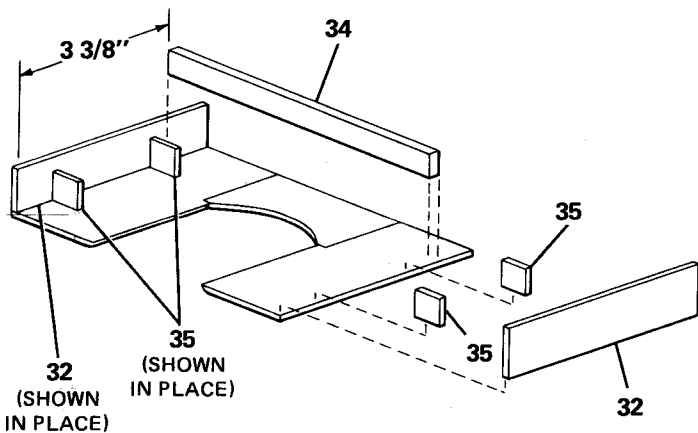

A. With front assembly remaining face down glue brace (34) to back of assembly $3 \frac{5}{16}$ inches from bottom and centered on assembly.

B. Glue two sides (32) to assembly.

NOTE: The gussets (35) support the sides (32).

D. Glue the four gussets (35) to the assembly as shown. Position is not critical.

Step 4

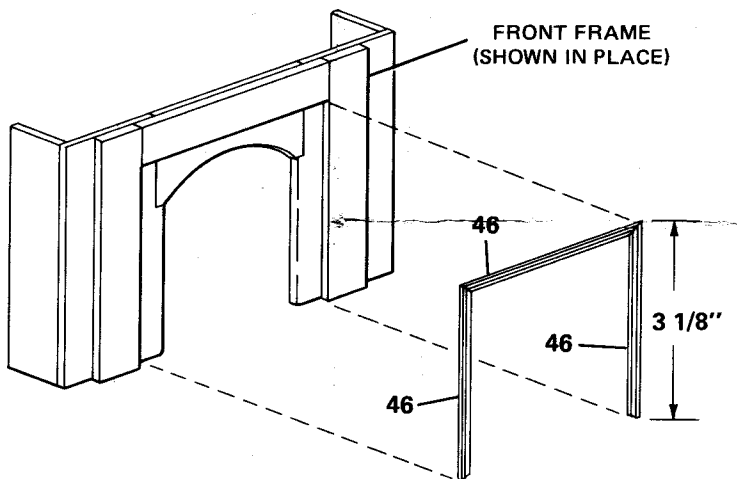

A. Center and glue front frame to assembly. Ensure top and bottom are flush.

NOTE: Refer to mitering in the introduction for a brief explanation of terms before proceeding.

B. Miter cut three pieces of inside molding (46) $3 \frac{1}{8}$ inches long (two lengths are mitered on one end only).

C. Glue molding (46) to main assembly on the inside edge of the front frame.

Detail Views

KIT 41220

Step 5

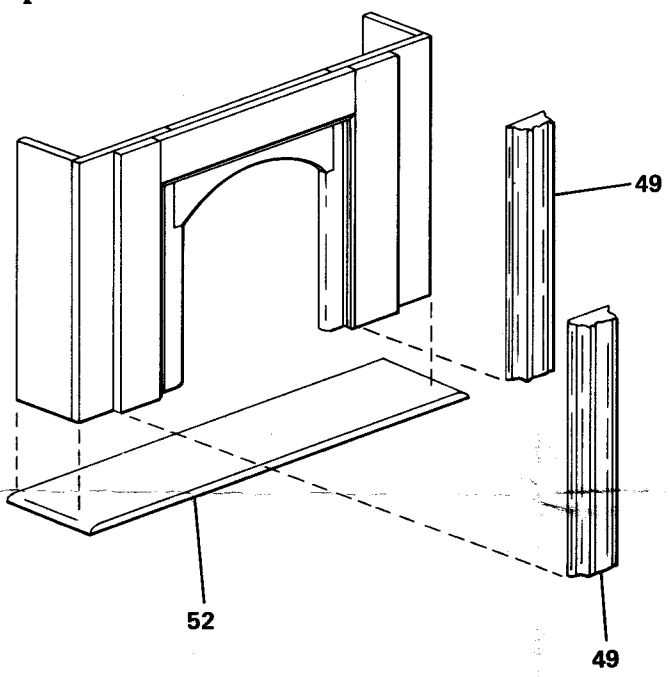

A. Center and glue bottom hearth (52) to assembly keeping rear edges flush and with 1/4 round edges up.
 B. Center and glue special columns (49) to front frame.

Step 7

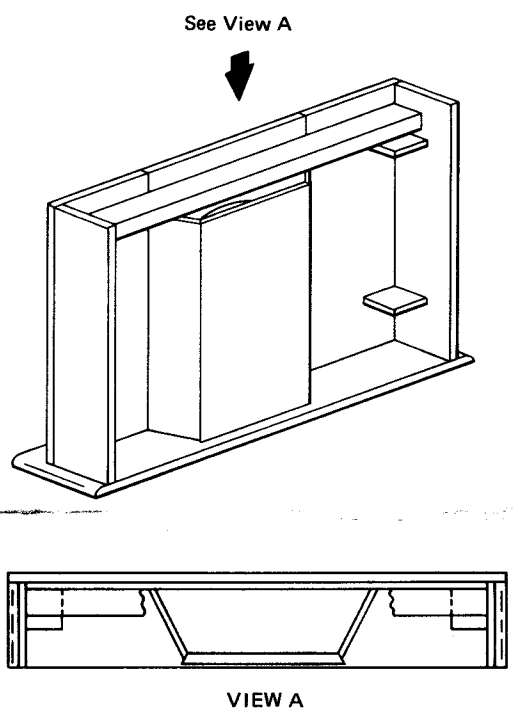

NOTE: Ensure firebox is centered and chamfered edges are against main assembly.
 A. Glue firebox assembly to main assembly.
 NOTE: Firebox should not extend beyond back.

Step 6

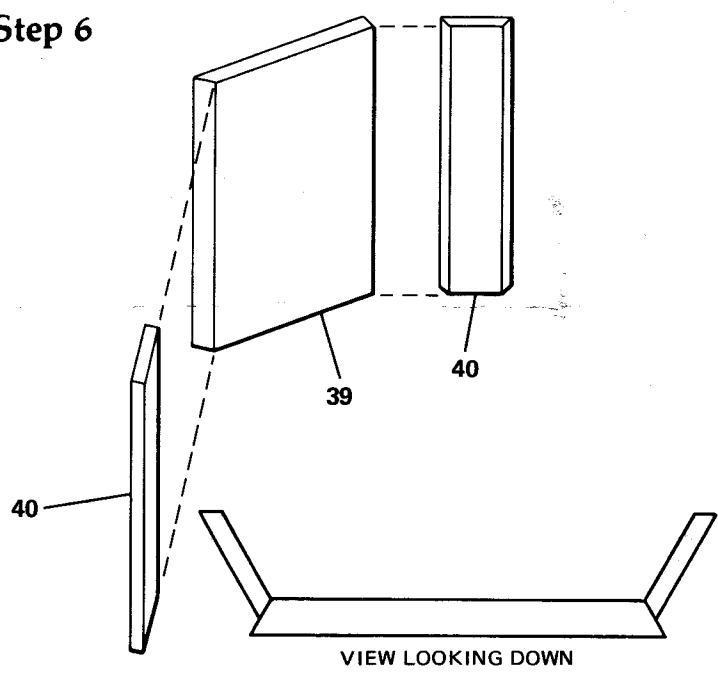

NOTE: The fire box sides (40) and back (39) are chamfered to insure proper alignment after gluing.
 A. Glue sides (40) to back (39).

Step 8

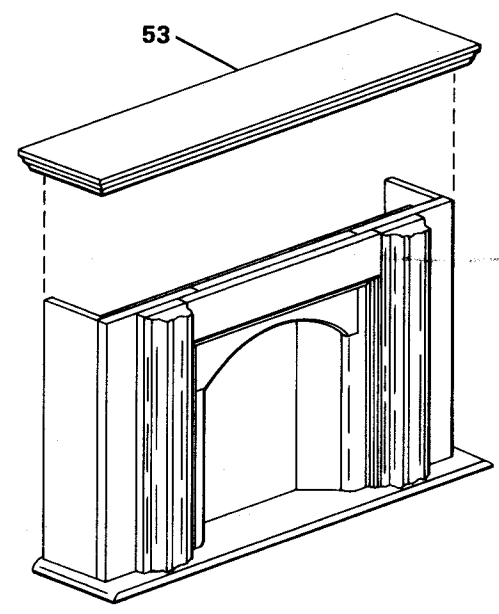

A. Center and glue mantle (53) to main assembly keeping rear edges flush.
 B. Sand arch to match contour of sides.
 NOTE: Refer to Final Finishing.

)