

COLLECTORS NO. 40078



Duncan Phyfe
Window Seat

Circa 1810-20

Window seats were very popular early in the 18th Century primarily due to the construction of the homes of that period. Homes, especially in the Northeast, were being built of stone and brick with walls that were often two feet, or more, thick. The windows were set back making an ideal space for, either a built in, or a window seat such as we have selected.

This seat has many of the features of one of Phyfe's most classic designs, the Saber Leg, Lyre Back chair. It is undoubtedly an adaptation of that design and was, perhaps, made for a room where the Lyre Back Chair was also used. The rear legs are the same, as are the lyre splats.

This type of chair was also used in places other than window alcoves. They could be used in hallways, in front of pier mirrors, or along the side walls of a ballroom. Many were also used in dressing, or bedrooms.

The seat was covered in rich fabrics which provided a contrast to the texture of the mahogany frame. In miniature this window seat will serve to add a touch of elegance to your room or hall.

ASSEMBLY AND FINISHING INSTRUCTIONS



AUTHENTIC REPRODUCTIONS IN MINIATURE

The X-ACTO® HOUSE OF MINIATURES COLLECTORS SERIES of furniture and accessories have all been carefully researched by specialists through major museum and library collections to assure the highest quality of authenticity in reproduction. Details are extraordinarily accurate to satisfy the most discriminating miniaturist.

All wood parts are machined to assure accurate and precise acceptance of each piece by another.

For a complete catalog of the X-ACTO® HOUSE OF MINIATURES furniture line and accessories, write to:
THE HOUSE OF MINIATURES
Customer Service - Catalog Dept.
80 Newbridge Road
Bergenfield, NJ 07621

INTRODUCTION

BEFORE STARTING

Identify and account for each part by placing it on the Layout Sheet (make sure the correct layout sheet is used when working on multi-kit Instruction Sheets). Should any parts be missing, send a post card to:

THE HOUSE OF MINIATURES
Customer Service - Parts Dept.
2000 Craftmark Center
Statesville, NC 28677-2000

Please print Name, Address, Part Number (Number from Layout Sheet) and Kit Name and Number on card when ordering.

SANDING

Before assembly, sand all the outer surfaces of individual parts with 220 grit sandpaper, or finer, sanded in the same direction as the wood grain until the surface is smooth. Take care not to round any edges or corners of the pieces. Finish sanding with 280 grit sandpaper.

PRE-ASSEMBLY

A. After sanding, check the proper location and fit of each part by assembling parts loosely, without gluing. Use the **DETAIL VIEWS** as a guide.

B. All parts for X-ACTO kits are made on precision

milling machines. When adjustments are required, sand to fit.

TOOLS AND MATERIALS

A. The following tools will be helpful in constructing this kit:

1. 2" Sander, X-ACTO No. 7042
2. Small Clamp, X-ACTO No. 7003
3. X-ACTO Professional Finishing Kit (or equivalent, see note)

B. The following materials will be needed to construct this kit:

1. X-ACTO Tinted Glue (see note)
2. Sandpaper - 220 and 280 grit
3. Small Artist's Brush

NOTE: The X-ACTO tinted glue is matched to the finish used in the Professional Finishing Kit. This will produce the authentic finish of the period in which the original Furniture was produced. When not using X-ACTO glue follow manufacturer's directions.

GLUING

A. Glue should be applied in small amounts to surface being joined. When gluing dado joints apply glue to dado only.

B. To ensure a tight fit, squeeze excess glue out of the joints. Hold glued parts together with clamps, rubber bands or weights on the parts.

C. Wipe off excess glue promptly.

D. Be sure a glued assembly has dried thoroughly before adding parts.

FINISHING

The X-ACTO Professional Finishing Kit enables you to finish your furniture by the same process used by the professional furniture maker. The end result is what is important — there are easier methods, but none that will give the quality results that this process will. If you use a finish other than X-ACTO's, refer to the manufacturer's directions.

Detail Views

Kit 40078

Layout Sheet

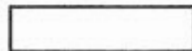
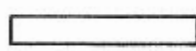
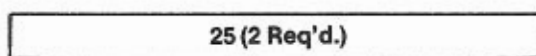
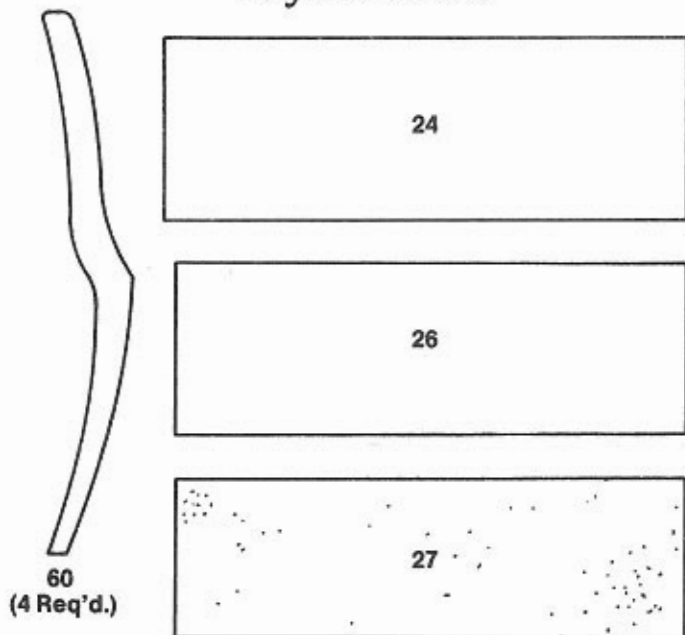

MATERIAL - 28 (not shown)

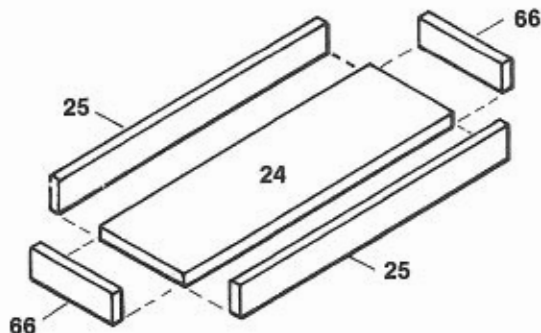

Step 1

A. Glue the side rails (25) and the end rails (66) to seat bottom (24). They should be flush on the bottom and form a notch in each corner.

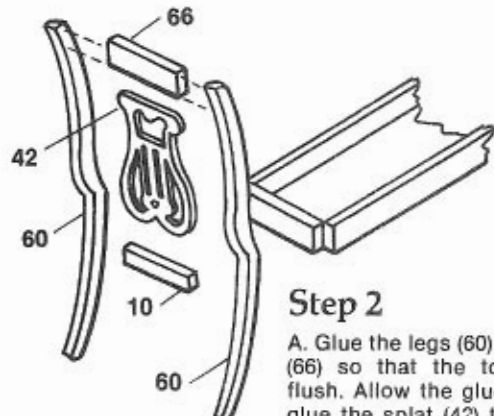

Step 2

A. Glue the legs (60) to the top rail (66) so that the top edges are flush. Allow the glue to set, then glue the splat (42) to the top rail (66) and glue the lower rail (10) to the bottom of the splat and the legs. Allow the glue to set. Make two sets of these.

B. Glue one leg and back assembly to the seat assembly made in Step 1. The flat surface at the front of the legs fits into the notches at the end of the seat. The bottom of the curve of the back should meet the top of the side rail.

C. Mount the other leg and back assembly. Apply stain and final finish to the window seat.

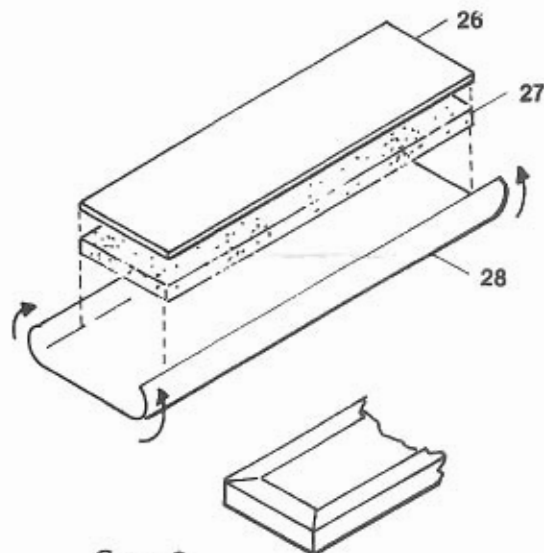

Step 3

A. Glue the cushion base (26) to the foam cushion (27). Lay the foam side on the material (28) and glue (with white glue) the material to the base on the two long sides. Fold the ends neatly and glue to the base. Cut away the excess material at the corners. Glue the cushion in place on the window seat.