

COLLECTORS NO. 40065



**Hepplewhite
Serving Table**

Circa 1780-1800

The original of this graceful serving table was believed to have been crafted by John or Thomas Seymour. The serpentine sides and bow front give this table an unusual, yet attractive, shape. The sides were flame satinwood panels and the front apron was crossbanded with rosewood.

The graceful tapered legs had line inlaid borders and cuffs.

Serving tables were somewhat taller and had larger top surface areas than ordinary side tables. One or more tables such as this were used in the dining rooms of the Colonial homes and they were occasionally used in other rooms where liquors or tea was being served.

Hepplewhite's design genius is best illustrated by tables similar to this one. His almost exclusive use of tapered legs on his small tables and his skillful use of decorative inlays gave Hepplewhite's furniture an easily identifiable style. The simple lines of his pieces gave them a fragile, light look that was appealing and a refreshing change after the heavy and massive appearance of the furniture of earlier periods.

This reproduction will allow you to provide additional serving areas in your miniature dining room as did the original two centuries ago.

ASSEMBLY AND FINISHING INSTRUCTIONS



AUTHENTIC REPRODUCTIONS IN MINIATURE

The X-ACTO® House of Miniatures Collectors Series™ of furniture and accessories have all been carefully researched by specialists through major museum and library collections to assure the highest quality of authenticity in reproduction. Details are extraordinarily accurate to satisfy the most discriminating miniaturist.

All wood parts are machined to assure accurate and precise acceptance of each piece by another.

For a complete catalog of the X-ACTO® HOUSE OF MINIATURES furniture line and accessories, write to:

X-ACTO® THE HOUSE OF MINIATURES Dept. KIT
45-35 Van Dam Street
Long Island City,
New York 11101

Please include \$2.00 for postage and handling.

TheHouseOfMiniature.com

INTRODUCTION

BEFORE STARTING

Identify and account for each part by placing it on the Layout Sheet (make sure the correct layout sheet is used when working on multi-kit Instruction Sheets). Should any parts be missing, send a post card to:

X-ACTO/The House of Miniatures
45-35 Van Dam Street
Long Island City, N.Y. 11101

Please print Name, Address, Part Number (Number from Layout Sheet) and Kit Name and Number on card when ordering.

SANDING

Before assembly, sand all the outer surfaces of individual parts with 220 grit sandpaper, or finer, sanded in the same direction as the wood grain until the surface is smooth. Take care not to round any edges or corners of the pieces. Finish sanding with 280 grit sandpaper.

PRE-ASSEMBLY

A. After sanding, check the proper location and fit of each part by assembling parts loosely, without gluing. Use the **DETAIL VIEWS** as a guide.

B. All parts for X-ACTO kits are made on precision milling machines. When adjustments are required, sand to fit.

TOOLS AND MATERIALS

A. The following tools will be helpful in constructing this kit:

1. X-ACTO One-inch Sander No. 7041
2. X-ACTO Small Clamp No. 7003
3. X-ACTO Professional Finishing Kit (or equivalent, see note)

B. The following materials will be needed to construct this kit:

1. X-ACTO Tinted Glue (see note)
2. Sandpaper - 220 and 280 grit
3. White glue (or equivalent)
4. Small Artist's Brush

NOTE: The X-ACTO tinted glue is matched to the finish used in the Professional Finishing Kit. This will produce the authentic finish of the period in which the original Furniture was produced. When not using X-ACTO glue follow manufacturer's directions.

GLUING

A. Glue should be applied in small amounts to surface being joined. When gluing dado joints apply glue to dado only.

B. To ensure a tight fit, squeeze excess glue out of the joints. Hold glued parts together with clamps, rubber bands or weights on the parts.

C. Wipe off excess glue promptly.

D. Be sure a glued assembly has dried thoroughly before adding parts.

FINISHING



The X-ACTO Professional Finishing Kit enables you to finish your furniture by the same process used by the professional furniture maker. The end result is what is important — there are easier methods, but none that will give the quality results that this process will. If you use a finish other than X-ACTO's, refer to the manufacturer's directions.

Detail Views

Kit 40065

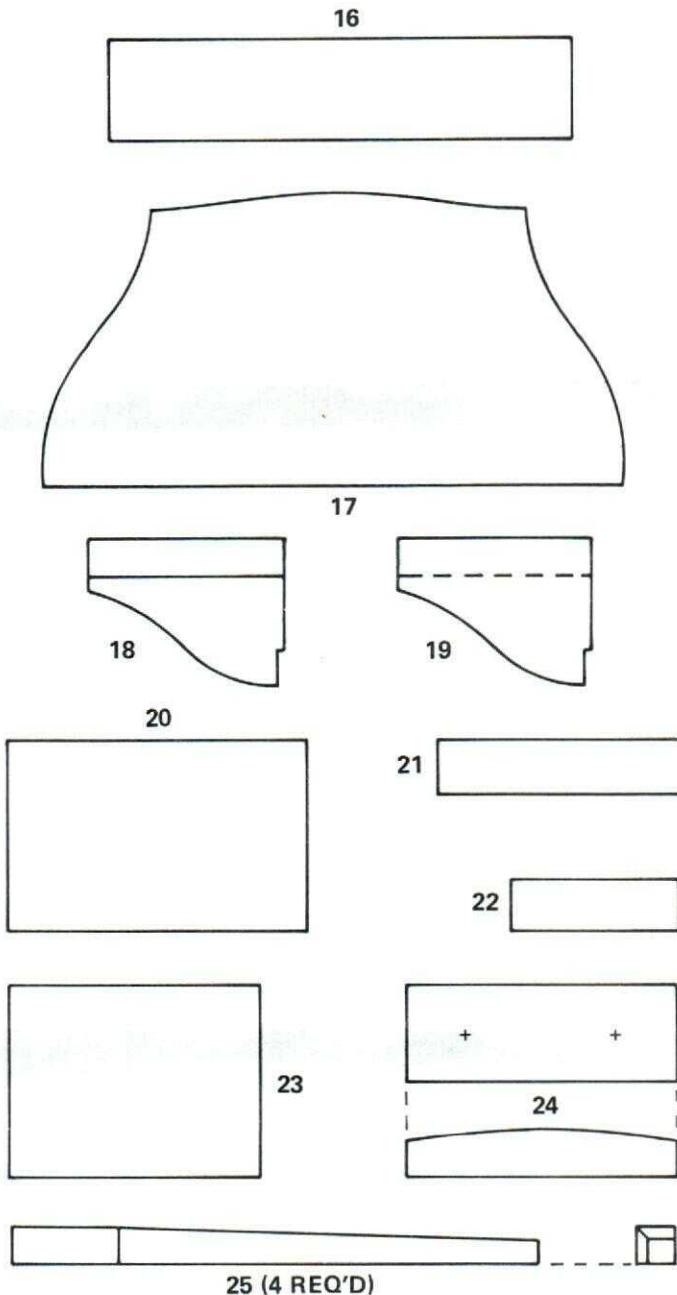
Layout Sheet



Description	Visual	Qty
Knob		2
Plate		2

Step 1

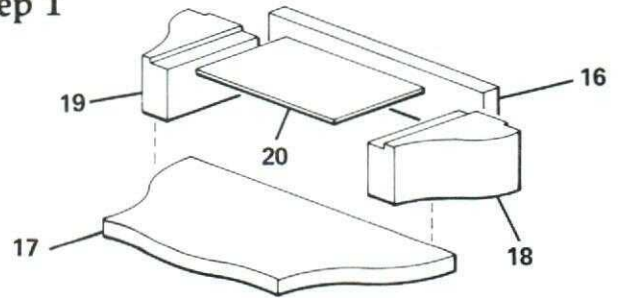

- A. Glue the sides (18) & (19) to the bottom (20). Glue the back (16) in place to align the assembly.
- B. Glue the base assembly to the top (17) so that the backs are flush and the base is centered on the top.

Step 2

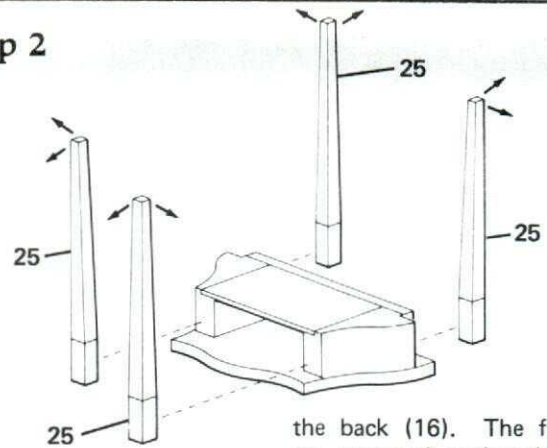

- A. Glue the legs (25) in place. The straight sides of the legs should face outward as indicated by the arrows. The rear legs fit into the notches formed by the sides (18) & (19) and the back (16). The front legs are mounted so that their outer edges are flush with the sides (18) & (19). Check that all the legs are straight.
- B. This assembly is now ready for the final finish.

Step 3

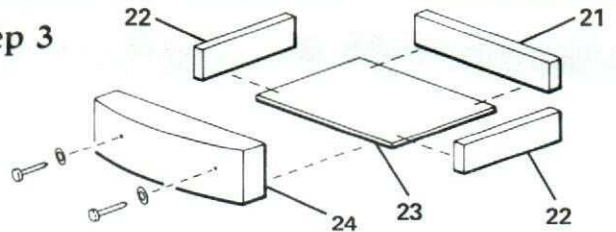

- A. Glue the two sides (22) onto the base (23) so that they are flush with the front edge and sides. The drawer front (24) should be mounted so that it is flush with the top of the sides (22), forming a lip on the bottom that overlaps the front of the base bottom (20).
- B. Glue the back (21) to the ends of the sides (22) and on the bottom (23).
- C. If the interior of the drawers are not to be stained apply the final finish to the front (24) before completing assembly.
- D. Use the guide marks on the layout sheet to locate where to drill the holes for the knobs. A drop of white glue on the back of the plates will keep them in place.