

COLLECTORS NO. 40057



Firescreen
Circa 1775

The word firescreen usually brings to mind the device that is placed in front of a fireplace to prevent coals or sparks from burning the carpet. However, the firescreen in centuries past filled various roles.

The one that we have reproduced in miniature, and some of other design, were placed between the fire and a lady's chair to protect her stylishly pale complexion from taking on, what was thought to be, an unattractive rosey glow from the heat of the fire. In this way, she could sit close enough to the fire to be comfortable, yet remain attractive.

The screens came in various sizes and shapes and were often lavishly decorated. Some screens were frames upon which the lady of the house could display her needlepoint skills.

The screens were often adjustable in height and some, like the one we have reproduced, had a small shelf on which one could place a candle and holder.

After stoves and later central heating replaced fireplaces, most of these screens were discarded. Very few of them are around today, since they had no secondary purpose.

ASSEMBLY AND FINISHING INSTRUCTIONS



AUTHENTIC REPRODUCTIONS IN MINIATURE

The X-ACTO® House of Miniatures® Collectors Series of furniture and accessories have all been carefully researched by specialists through major museum and library collections to assure the highest quality of authenticity in reproduction. Details are extraordinarily accurate to satisfy the most discriminating miniaturist.

All wood parts are machined to assure accurate and precise acceptance of each piece by another.

For a complete catalog of the X-ACTO® HOUSE OF MINIATURES furniture line and accessories, write to:

X-ACTO® THE HOUSE OF MINIATURES Dept. KIT
45-35 Van Dam Street
Long Island City,
New York 11101

Please include \$2.00 for postage and handling.

INTRODUCTION

BEFORE STARTING

Identify and account for each part by placing it on the Layout Sheet (make sure the correct layout sheet is used when working on multi-kit Instruction Sheets). Should any parts be missing, send a post card to:

X-ACTO/The House of Miniatures
45-35 Van Dam Street
Long Island City, N.Y. 11101

Please print Name, Address, Part Number (Number from Layout Sheet) and Kit Name and Number on card when ordering.

SANDING

Before assembly, sand all the outer surfaces of individual parts with 220 grit sandpaper, or finer, sanded in the same direction as the wood grain until the surface is smooth. Take care not to round any edges or corners of the pieces. Finish sanding with 280 grit sandpaper.

PRE-ASSEMBLY

A. After sanding, check the proper location and fit of each part by assembling parts loosely, without gluing. Use the **DETAIL VIEWS** as a guide.

B. All parts for X-ACTO kits are made on precision milling machines. When adjustments are required, sand to fit.

TOOLS AND MATERIALS

A. The following tools will be helpful in constructing this kit:

1. One-inch Sander, X-ACTO No. 7041
2. Small Clamp, X-ACTO No. 4003
3. X-ACTO Professional Finishing Kit (or equivalent, see note)

B. The following materials will be needed to construct this kit:

1. X-ACTO Tinted Glue (see note)
2. Sandpaper 220 and 280 grit
3. Steel Wool - Grade 0000
4. Small Artist's Brush

NOTE: The X-ACTO tinted glue is matched to the finish used in the Professional Finishing Kit. This will produce the authentic finish of the period in which the original Furniture was produced. When not using X-ACTO glue follow manufacturer's directions.

GLUING

A. Glue should be applied in small amounts to surface being joined. When gluing dado joints apply glue to dado only.

B. To ensure a tight fit, squeeze excess glue out of the joints. Hold glued parts together with clamps, rubber bands or weights on the parts.

C. Wipe off excess glue promptly.

D. Be sure a glued assembly has dried thoroughly before adding parts.

FINISHING

The X-ACTO Professional Finishing Kit enables you to finish your furniture by the same process used by the professional furniture maker. The end result is what is important — there are easier methods, but none that will give the quality results that this process will. If you use a finish other than X-ACTO's refer to the manufacturer's directions.

Detail Views

Kit 40057

Step 1

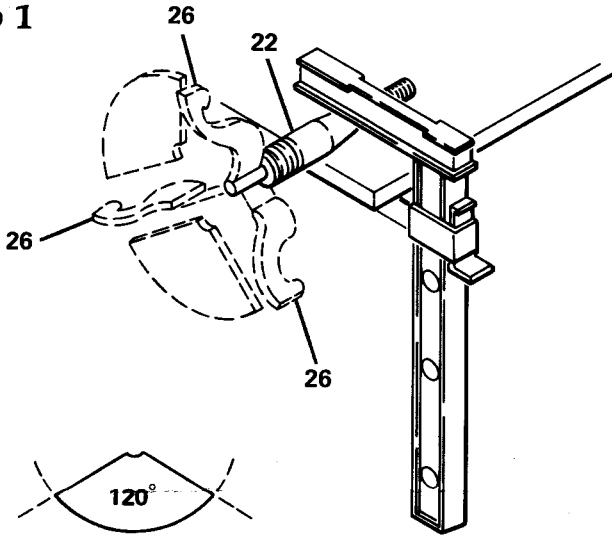

A. Shape all three legs (26) by rounding all edges except edge that connects to the pedestal.

B. Clamp or tape the pedestal (22) to the edge of a table or flat surface. Glue one leg (26) to the base of the pedestal. Allow to set firmly.

C. Cut out the 120°. Guide to use in positioning other two legs. Glue legs on one at a time allowing glue to set firmly each time.

D. Once glue has set firmly check that base sets level. Sand legs on side opposite the direction of tilt if not level.

Layout Sheet

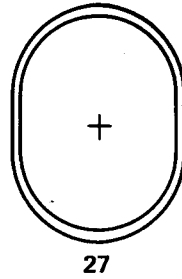

27

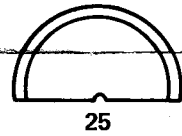

25



24



22



23



26 (3 REQ'D)

Step 2

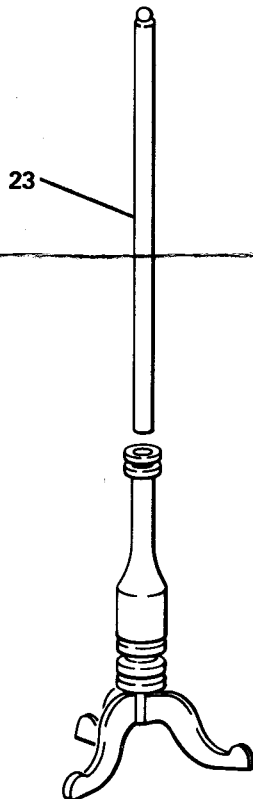

A. Glue post (23) into hole in pedestal.

Step 3

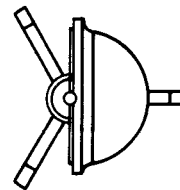

Top View

NOTE: Use top view as a guide to positioning screen and candle shelf in relation to the leg. Position of these parts on the post is a matter of judgement since originals were adjustable.

A. Glue bracket (24) and candle shelf (25) to the post.

B. Glue screen (27) to post.

C. Apply Final Finish.

