

COLLECTORS NO. 40055

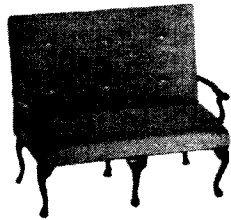

Queen Anne Settee
Circa 1730

This graceful, cabriole legged, settee combined the art of the cabinet maker and the upholsterer into a fine piece of furniture.

These pieces were upholstered in a variety of fabrics; sometimes linen-backed needlepoint created by the lady of the house or a local artisan.

The fine finished mahogany legs and arms provided just enough contrast to the upholstery to make the eye appreciate each of them.

Our settee is more formal than some designs and was probably used in the parlor or sitting room. It was probably not used in a hallway, except in the most elegant of homes.

The tufting on the back of the seat was held to a minimum, and was only used to break the overstuffed appearance of the fairly large flat surface of the back.

The Queen Anne era introduced a new elegance and grace in furniture design, which has survived to the present time.

ASSEMBLY AND FINISHING INSTRUCTIONS



AUTHENTIC REPRODUCTIONS IN MINIATURE

The X-ACTO® House of Miniatures® Collectors Series of furniture and accessories have all been carefully researched by specialists through major museum and library collections to assure the highest quality of authenticity in reproduction. Details are extraordinarily accurate to satisfy the most discriminating miniaturist.

All wood parts are machined to assure accurate and precise acceptance of each piece by another.

For a complete catalog of the X-ACTO® HOUSE OF MINIATURES furniture line and accessories, write to:

X-ACTO® THE HOUSE OF MINIATURES Dept. KIT
45-35 Van Dam Street
Long Island City,
New York 11101

Please include \$2.00 for postage and handling.

TOOLS AND MATERIALS

A. The following tools will be helpful in constructing this kit:

1. X-ACTO Professional Finishing Kit (or equivalent, see note)

B. The following materials will be needed to construct this kit:

1. X-ACTO Tinted Glue (see note)
2. Sandpaper - 220 and 280 grit
3. Steel Wool - Grade 0000
4. White glue (or equivalent)
5. Small Artist's Brush

NOTE: The X-ACTO tinted glue is matched to the finish used in the Professional Finishing Kit. This will produce the authentic finish of the period in which the original Furniture was produced. When not using X-ACTO glue follow manufacturer's directions.

GLUING

A. Glue should be applied in small amounts to surface being joined. When gluing dado joints apply glue to dado only.

B. To ensure a tight fit, squeeze excess glue out of the joints. Hold glued parts together with clamps, rubber bands or weights on the parts.

C. Wipe off excess glue promptly.

D. Be sure a glued assembly has dried thoroughly before adding parts.

FINISHING

The X-ACTO Professional Finishing Kit enables you to finish your furniture by the same process used by the professional furniture maker. The end result is what is important — there are easier methods, but none that will give the quality results that this process will. If you use a finish other than X-ACTO's, refer to the manufacturer's directions.

INTRODUCTION

BEFORE STARTING

Identify and account for each part by placing it on the Layout Sheet (make sure the correct layout sheet is used when working on multi-kit Instruction Sheets). Should any parts be missing, send a post card to:

X-ACTO/The House of Miniatures
45-35 Van Dam Street
Long Island City, N.Y. 11101

Please print Name, Address, Part Number (Number from Layout Sheet) and Kit Name and Number on card when ordering.

SANDING

Before assembly, sand all the outer surfaces of individual parts with 220 grit sandpaper, or finer, sanded in the same direction as the wood grain until the surface is smooth. Take care not to round any edges or corners of the pieces. Finish sanding with 280 grit sandpaper.

PRE-ASSEMBLY

A. After sanding, check the proper location and fit of each part by assembling parts loosely, without gluing. Use the DETAIL VIEWS as a guide.

B. All parts for X-ACTO kits are made on precision milling machines. When adjustments are required, sand to fit.

Layout Sheet

Kit 40055

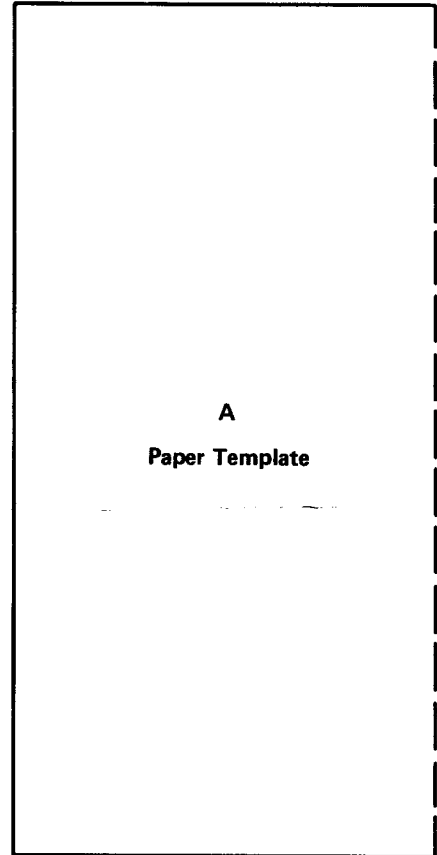
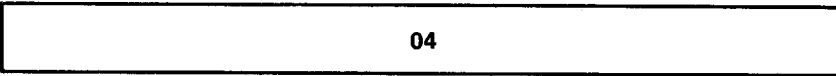
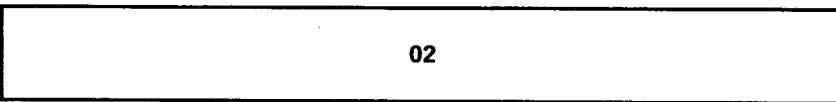
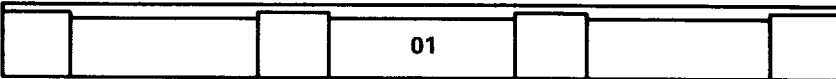
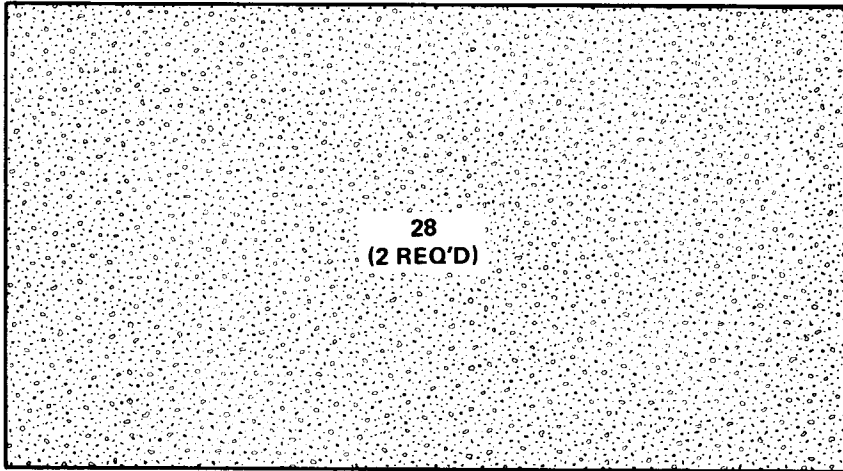

Step 1

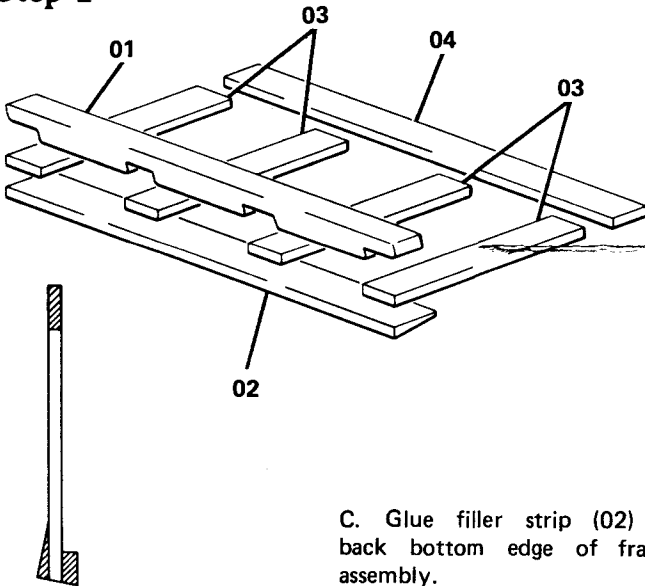

A. Glue vertical braces (03) into the dadoes and rabbets of the lower horizontal frame piece (01).

B. Glue upper rail (04) to ends of the vertical braces (03). Square entire assembly.

C. Glue filler strip (02) to back bottom edge of frame assembly.

NOTE: The edge of this strip is cut to a thin taper and may become chipped in cutting or shipping. This in no way effects its use since it will be completely covered later.

D. Sand bottom of assembly so all pieces are flush.

Step 2

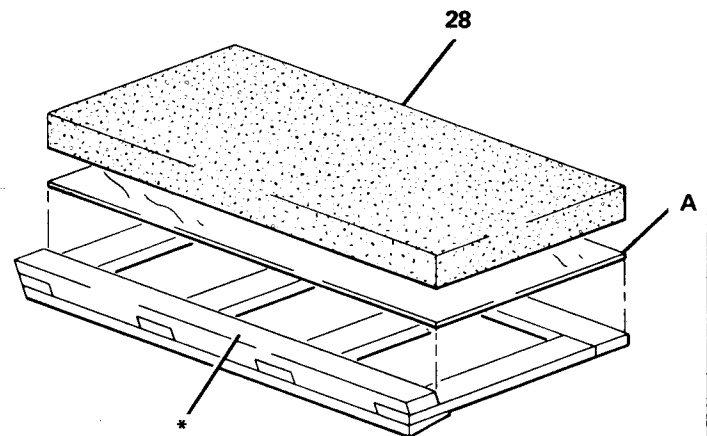

A. Glue Paper Template (A) to front of frame assembly.

B. Glue foam (28) to template (A). Trim to fit.

C. Cover as described in Step 4.

* When applying upholstery, glue material to this surface to ensure firm bond when seat is attached.

Detail Views

Kit 40055

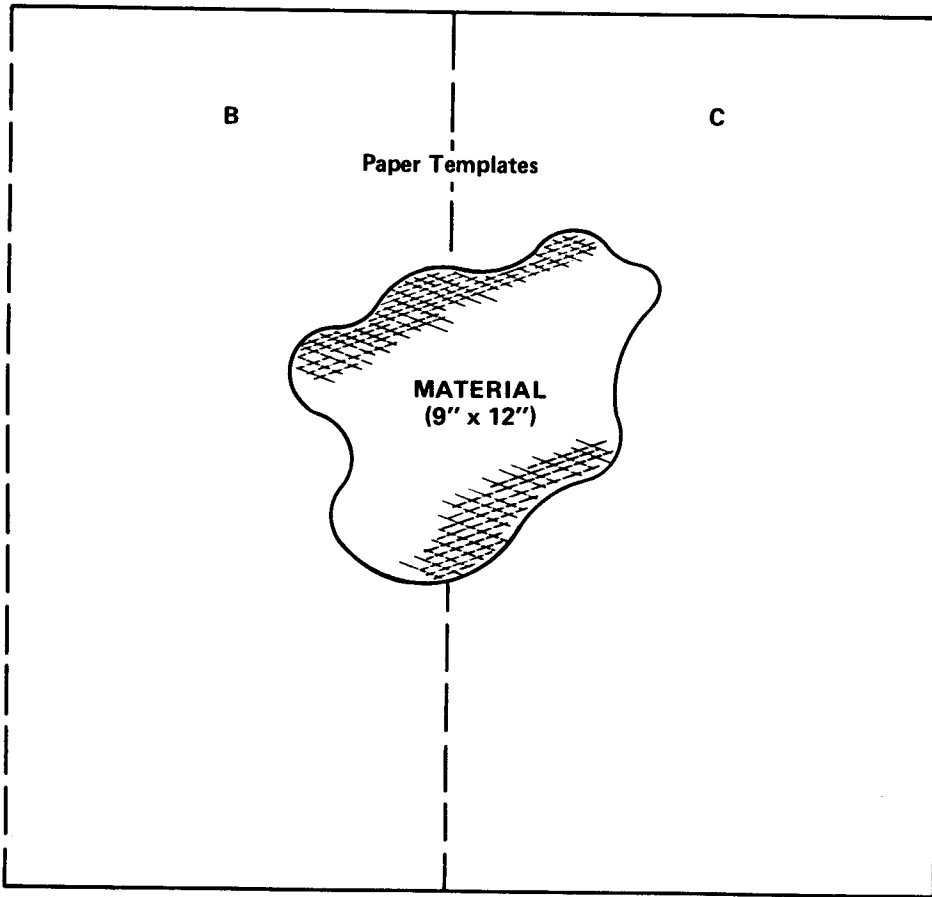

Layout Sheet

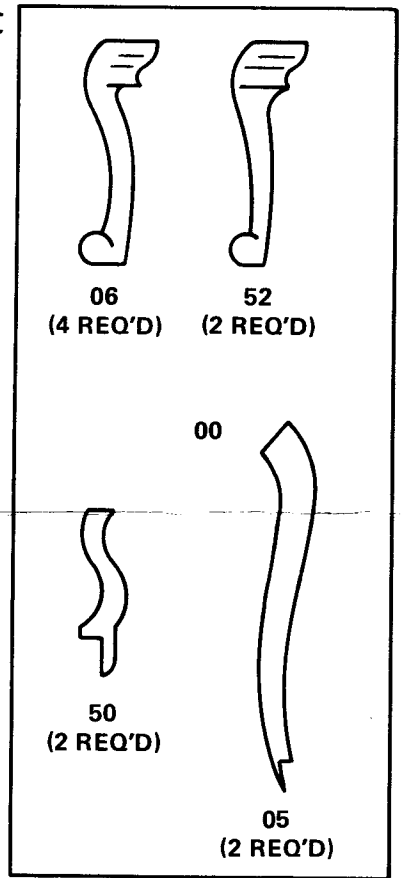

Step 3

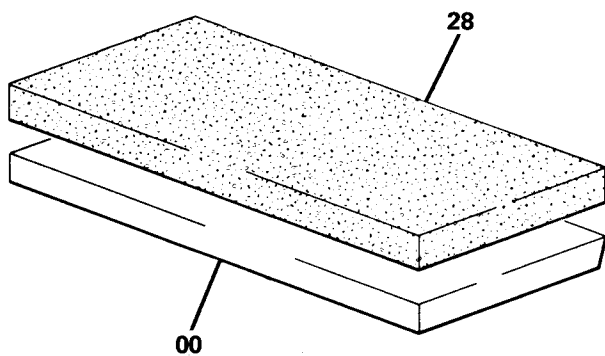

- A. Glue foam (28) to seat base (00). Foam should be flush with front square edge.
- B. Cover as described in Step 4.

Step 4

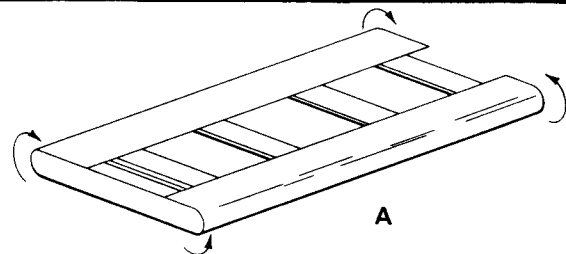

These are general instructions that apply to all parts of this settee.

- A. Lay part to be covered on material with the surface to be covered face down. Trim material allowing enough excess to overlap back enough to glue. Use white glue. Avoid staining finished area.
- B. Glue one of the long edges and allow glue to set up. Pull material smooth and taut and glue to opposite edge.
- C. Glue center sections of each end.

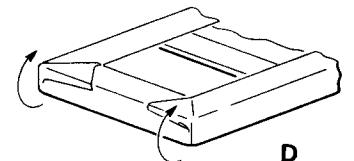
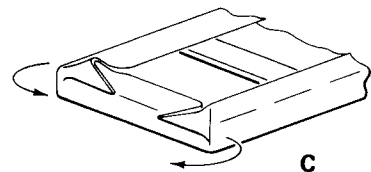
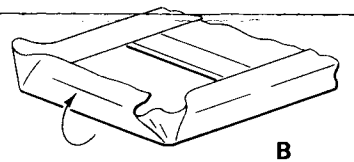

- D. Fold and glue corners. Try to eliminate excess build-up of material at corner. Trim as you go. Saturate excess material with glue and allow to dry. Carefully trim as flat as possible.

Detail Views

Kit 40055

Step 5

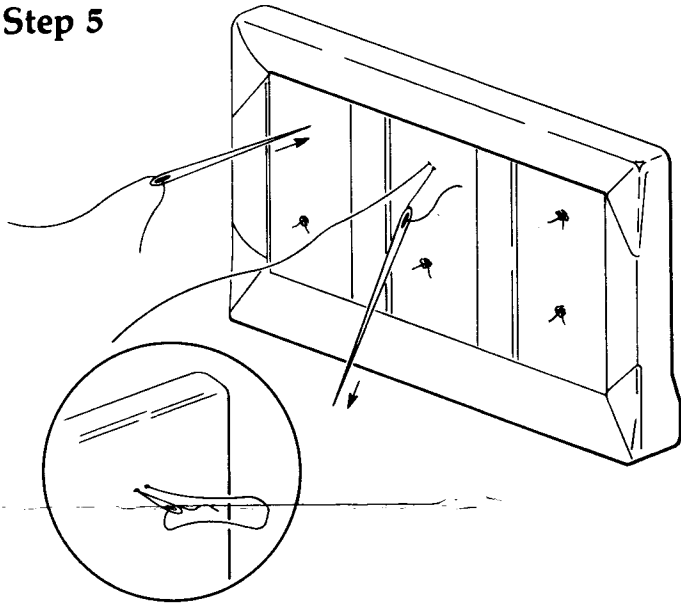

A. Tufting may be achieved by stitching through the template, foam, and material then knotting the thread, pulling it tight to achieve the tufted appearance.

B. Tufts are centered between braces $\frac{1}{3}$ from top and $\frac{1}{3}$

from the bottom of the opening formed by the braces and frames. Stitch should enter back $\frac{1}{8}$ " from each side of tuft location and only catch 3 or 4 threads of the material. After knotting put a drop of glue on knot to prevent it from loosening.

Step 6

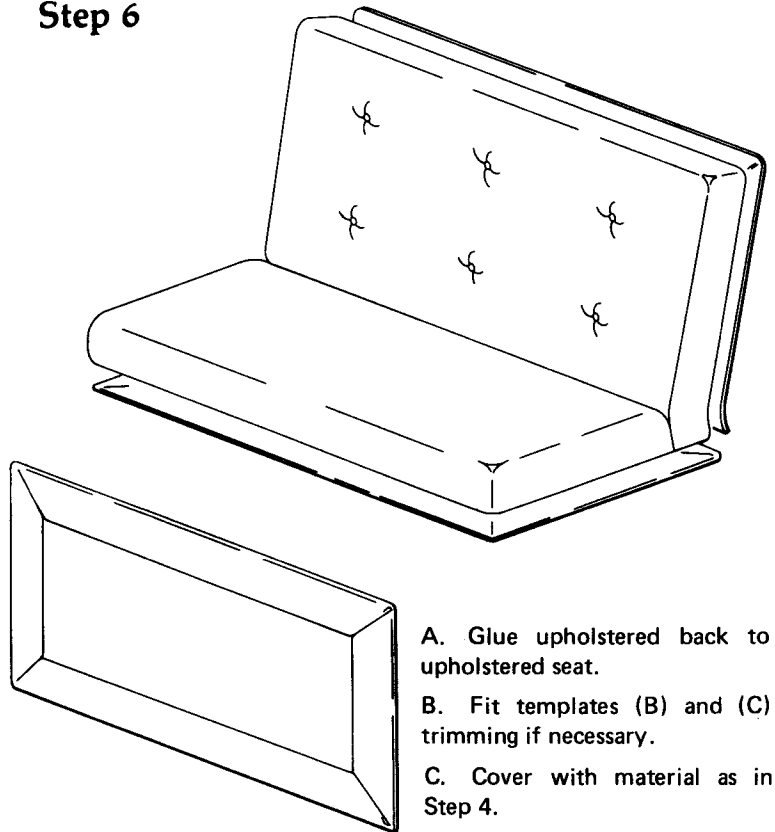

A. Glue upholstered back to upholstered seat.

B. Fit templates (B) and (C) trimming if necessary.

C. Cover with material as in Step 4.

D. Glue firmly in place.

Step 7

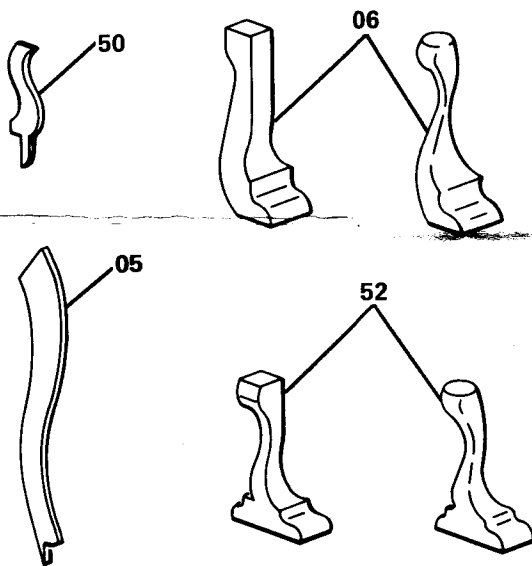

A. Round corner legs (06) and shape foot.

B. Round center legs (52) and shape foot.

C. Round all curved edges of arm brace (50) and arm (05).

D. Apply Final Finish.

Step 8

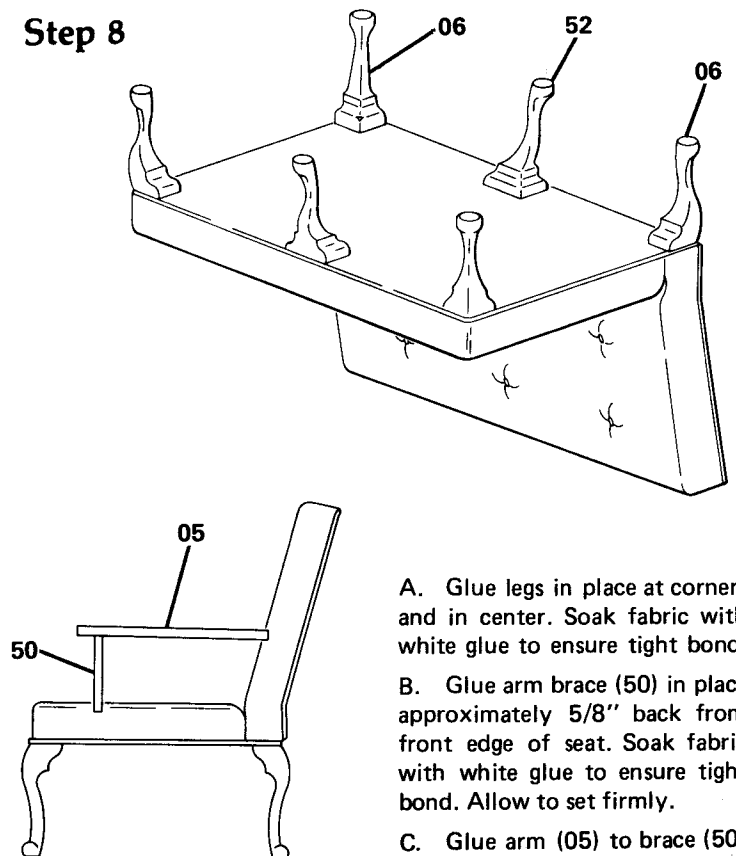

A. Glue legs in place at corners and in center. Soak fabric with white glue to ensure tight bond.

B. Glue arm brace (50) in place approximately $\frac{5}{8}$ " back from front edge of seat. Soak fabric with white glue to ensure tight bond. Allow to set firmly.

C. Glue arm (05) to brace (50) and to back. Arm curve flares outward.