

## COLLECTORS NO. 40054

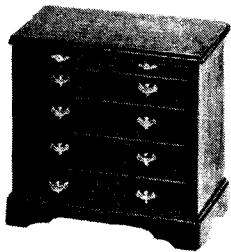

**Bachelor's Chest**  
Circa 1750

The bachelor of the 1700's was constantly changing his residence, as he sought to establish himself in a career. His quarters were often shared with several other men of the same status.

His possessions were few and were often able to fit into a chest such as the one that we have created in miniature. These chests were derived from the old campaign chests and were often brass bound.

This piece of furniture had many uses. It could be used as a chest of drawers for storing clothing; as a desk by pulling out the shelf; as a shaving stand by placing a wash bowl and mirror on top.

Many versions of these versatile chests have survived, possibly due to their sturdy design and their usefulness.

Once the bachelor settled down at a permanent residence, a chest was used as a bedside table, a lamp stand, or for storage in almost any room.

## ASSEMBLY AND FINISHING INSTRUCTIONS



AUTHENTIC REPRODUCTIONS IN MINIATURE

The X-ACTO® House of Miniatures® Collectors Series of furniture and accessories have all been carefully researched by specialists through major museum and library collections to assure the highest quality of authenticity in reproduction. Details are extraordinarily accurate to satisfy the most discriminating miniaturist.

All wood parts are machined to assure accurate and precise acceptance of each piece by another.

For a complete catalog of the X-ACTO® HOUSE OF MINIATURES furniture line and accessories, write to:

**THE HOUSE OF MINIATURES**  
Customer Service - Catalog Dept.  
80 Newbridge Road  
Bergenfield, NJ 07621

## INTRODUCTION

## BEFORE STARTING

Identify and account for each part by placing it on the Layout Sheet (make sure the correct layout sheet is used when working on multi-kit Instruction Sheets). Should any parts be missing, send a post card to:

**THE HOUSE OF MINIATURES**  
Customer Service - Parts Dept.  
2000 Craftmark Center  
Statesville, NC 28677-2000

Please print Name, Address, Part Number (Number from Layout Sheet) and Kit Name and Number on card when ordering.

## SANDING

Before assembly, sand all the outer surfaces of individual parts with 220 grit sandpaper, or finer, sanded in the same direction as the wood grain until the surface is smooth. Take care not to round any edges or corners of the pieces. Finish sanding with 280 grit sandpaper.

## PRE-ASSEMBLY

A. After sanding, check the proper location and fit of each part by assembling parts loosely, without gluing. Use the **DETAIL VIEWS** as a guide.

B. All parts for X-ACTO kits are made on precision milling machines. When adjustments are required, sand to fit.

## TOOLS AND MATERIALS

A. The following tools will be helpful in constructing this kit:

1. Two inch Sander, X-ACTO No 7042
2. Large Clamp, X-ACTO No. 4004
3. Small Clamp, X-ACTO No. 4003
4. X-ACTO Professional Finishing Kit (or equivalent, see note)

B. The following materials will be needed to construct this kit:

1. X-ACTO Tinted Glue (see note)
2. Waxed paper
3. Sandpaper 220 and 280 grit
4. Steel Wool - Grade 0000
5. White glue (or equivalent)
6. Small Artist's Brush

**NOTE:** The X-ACTO tinted glue is matched to the finish used in the Professional Finishing Kit. This will produce the authentic finish of the period in which the original Furniture was produced. ~~When not using X-ACTO glue follow manufacturer's directions.~~

## GLUING

A. Glue should be applied in small amounts to surface being joined. When gluing dado joints apply glue to dado only.

B. To ensure a tight fit, squeeze excess glue out of the joints. Hold glued parts together with clamps, rubber bands or weights on the parts.

C. Wipe off excess glue promptly.

D. Be sure a glued assembly has dried thoroughly before adding parts.

## FINISHING

The X-ACTO Professional Finishing Kit enables you to finish your furniture by the same process used by the professional furniture maker. The end result is what is important — there are easier methods, but none that will give the quality results that this process will. If you use a finish other than X-ACTO's, refer to the manufacturer's directions.

# Layout Sheet

Kit 40054

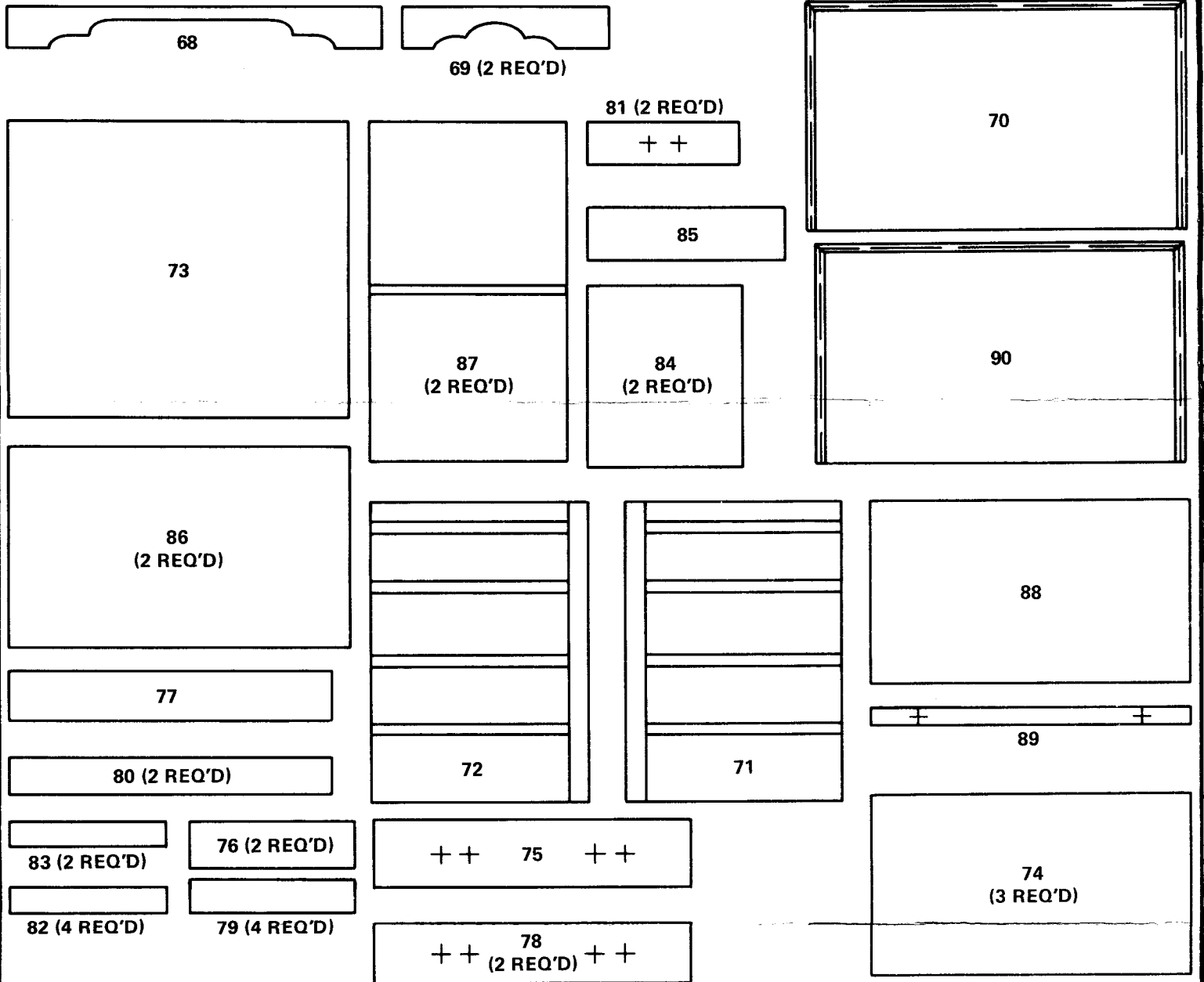

## Step 1

A. Place base (70) with contoured edge down. Glue bracket foot trim (68) to the bottom of the base flush with the front contoured edge.

B. Glue the side bracket foot trim (69) to the base (70) flush with the ends and against the front trim (68).

\*One foot of the side bracket foot trim is narrower than the other and should be glued forward and against the front trim (68).

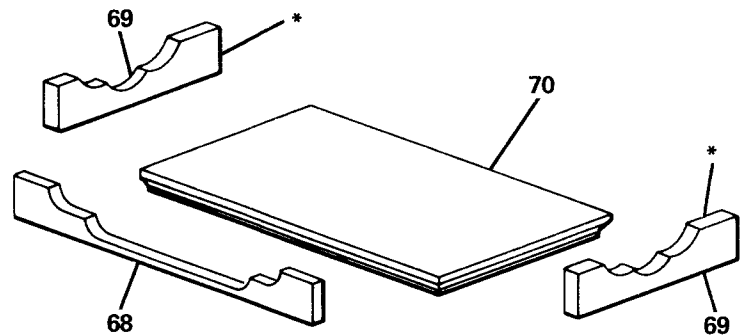

# Detail Views

Kit 40054

## Step 2

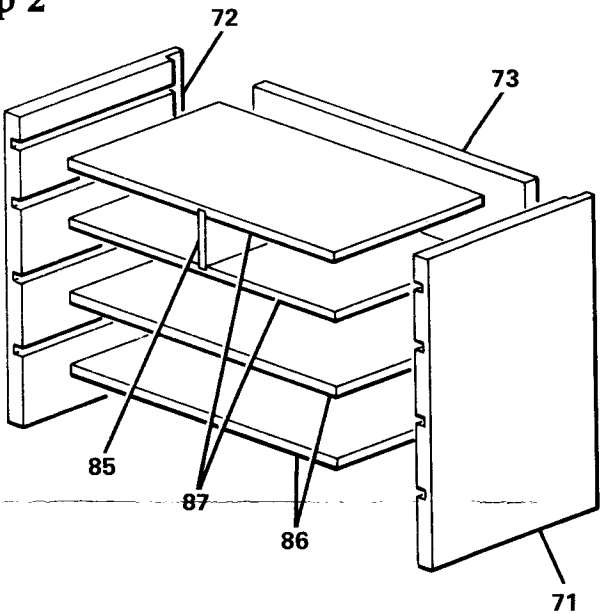

- A. Glue the divider (85) into the dadoes of the upper horizontal dividers (87).
- B. Now glue this set of dividers and lower dividers (86) into the rabbets at the rear of the sides.
- C. Glue back (73) to the dividers and sides.

## Step 3

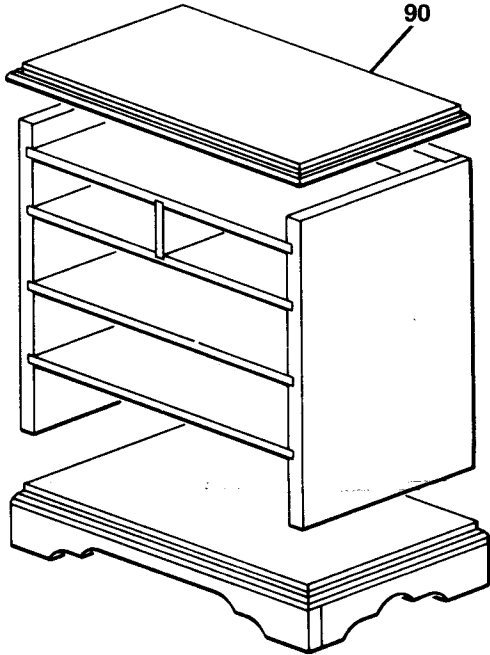

- A. Glue case assembly made in Step 2 to the base assembly made in Step 1. Line up front edges and center on the base.
- B. Glue on the top (90) lining up the front and sides. Sand back of assembly flush.
- C. Apply Final Finish.

## Step 4

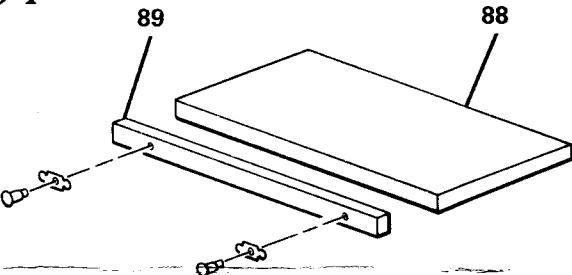

- A. Pre-drill holes for knobs in trim strip (89). Glue trim strip (89) to pull shelf (88).
- B. Apply Final Finish.
- C. Install knobs and escutcheon plates as shown.

## Step 5

	A	B	C	D
TOP DRAWERS	84	82	83	81
CENTER DRAWERS	74	79	80	78
BOTTOM DRAWER	74	76	77	75

**NOTE:** There are three sizes of drawers in this unit. Assembly is the same for all. Consult chart for proper part numbers.

- A. Glue sides (B) to bottom (A) so that they are flush with the front and edges.
- B. Glue back (C) on top of bottom (A) and to sides (B).
- C. Pre-drill holes for hardware using marks on layout sheet as a guide. If entire drawer is to be stained, front (D) may be glued on at this time. If drawer interiors are not to be stained, finish drawer fronts before gluing them on.
- D. Apply Final Finish.
- E. Install plates and handles.

HARDWARE CHECK LIST		
DESCRIPTION	VISUAL DESCRIPTION	QTY
HANDLE PLATE		8
HANDLE		8
ESCUTCHEON		2
KNOB		2

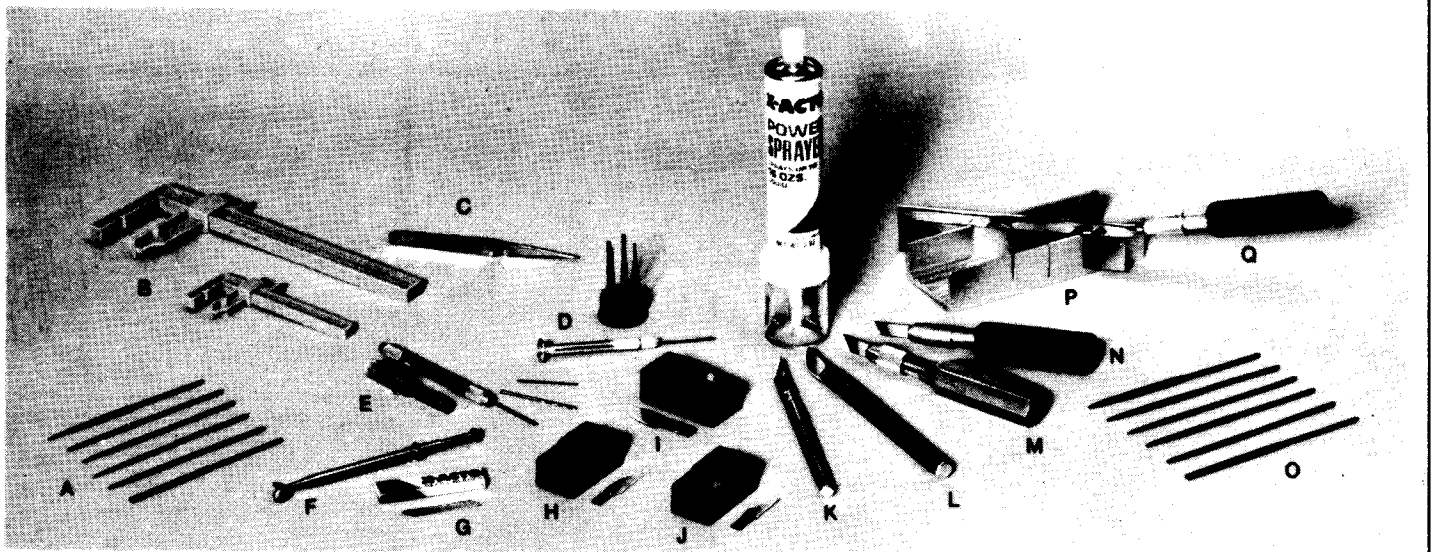

## X-ACTO precision tools make fine miniatures.

### A. MINIATURE FILE SET

6 miniature needle files. 3 1/8" long. For intricate filing. Vinyl storage pouch. No. 7365

### B. PLASTIC CLAMPS

Light duty plastic clamps for delicate work. Notched jaw allows grip of round parts. Smooth face prevents damage to workpiece.

**Small plastic clamp.** 3 1/4" opening with 1" throat depth.

2 per card: No. 7003

**Large plastic clamp.** 7 1/4" opening with 2 1/8" throat depth.

2 per card: No. 7004

### C. SELF-CLOSING POINTED TWEEZER

Self-closing serrated points. Nickel-plated steel. 6 1/2" Carded: No. 7337

### D. SCREWDRIVER WITH INTERCHANGEABLE BLADES

Aluminum handle and chuck and 5 steel screwdriver blades sizes .040" through .100". Notched shank for greater torque. Storage base. Carded: No. 7070

### E. PIN VISE SET

Includes double-ended pin vise, pin vise bit guard and 3 assorted drill bits. Carded: No. 7144

### F. PARTPICKER

For small hard-to-handle pieces. Smooth one-handed action. Carded: No. 7380

### G. No. 13 BLADE

Precision saw cutting. 5 blades. Carded: No. 213

### H. No. 10 BLADE

For fine general cutting, carving, correcting stencils. Safety dispenser of 10 blades. Carded: No. 410

### I. No. 22 BLADE

General shaping, whittling, trimming, removing excess flashing. Safety dispenser of 10 blades. Carded: No. 422

### J. No. 11 BLADE

Extremely sharp point for fine angle cutting and stripping. Safety dispenser of 10 blades. Carded: No. 411

### K. No. 1 KNIFE

Aluminum handle 4 7/8" long with No. 11 blade. Carded: No. 3201

### L. No. 2 KNIFE

Aluminum handle 5" long with No. 22 blade. Carded: No. 3202

### M. No. 6 KNIFE

Aluminum handle 4 3/4" long with No. 24 blade. Carded: No. 3206

### N. No. 5 KNIFE

Plastic handle with metal blade lock, 4 1/4" long with No. 19 blade. Carded: No. 3205

### O. MINIATURE NEEDLE RASPS

6 assorted rasps. For rough shaping of wood or plastic. 4 3/4" long. Vinyl storage pouch. No. 7366

### P. MITRE BOX

Aluminum 3/4" x 1 3/4" capacity. 6" long. With two 45° and one 90° cutting slots. Carded: No. 7533

### Q. EXTRA-FINE RAZOR SAW

1 1/4" deep with cutting edge 5 1/2" long and 54 teeth per inch for extra fine precision. For use with No. 7533 mitre box. Carded: No. 7535

### R. POWER SPRAYER

Push-button action sprays evenly. Includes a one ounce jar and propellant to spray on intricate or flat surfaces up to 16 ounces of liquid materials. Carded: No. 43561

### MINIATURIST'S TOOL SET

Basic tools for assembling miniatures, models and working with small parts. 4 clamps, tweezer, pin vise with 3 bits, 2 sanders, screwdriver and No. 1 Knife in fitted tray. No. 43910

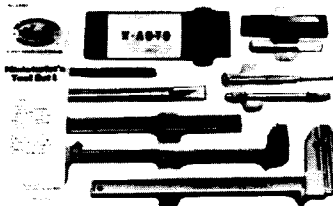

### DELUXE MINIATURIST'S TOOL CHEST

Fitted wooden chest contains precision tools for assembling miniatures, models and working with small parts: razor saw blade, mitre box, 4 clamps, pin vise and 3 bits, Nos. 1 and 5 Knives, sanders and screwdriver. Boxed: No. 43911