

ASSEMBLY AND FINISHING INSTRUCTIONS

COLLECTORS NO. 40049



Chippendale
Candlestands
Circa 1750

Chippendale's treatment of the designs of his candlestands didn't differ appreciably from his styling of any other piece of furniture. The cyma curved legs were often terminated in a ball-and-claw foot and the pedestals were usually embellished with ornate carving.

The tops usually were fairly plain since, due to their limited size, the candle holders, or other more decorative objects, covered most of the surface. The wood used in their construction was typically mahogany although the American cabinetmakers relied heavily upon native woods.

These tables had a high utilitarian value and were in great demand in the Colonial household. They were gradually replaced later in the 18th century, with the introduction of oil lamps, by a more stable, four-legged stand. Even after they were no longer used for lighting they still found a place in the homes as depositories of decorative vases and statuary. Surviving pieces are always in demand by collectors today.



AUTHENTIC REPRODUCTIONS IN MINIATURE

The X-ACTO® House of Miniatures Collectors Series® of furniture and accessories have all been carefully researched by specialists through major museum and library collections to assure the highest quality of authenticity in reproduction. Details are extraordinarily accurate to satisfy the most discriminating miniaturist.

All wood parts are machined to assure accurate and precise acceptance of each piece by another.

For a complete catalog of the X-ACTO® HOUSE OF MINIATURES furniture line and accessories, write to:

THE HOUSE OF MINIATURES
Customer Service - Catalog Dept.
80 Newbridge Road
Bergenfield, NJ 07621

410P49

INTRODUCTION

BEFORE STARTING

Identify and account for each part by placing it on the Layout Sheet (make sure the correct layout sheet is used when working on multi-kit Instruction Sheets). Should any parts be missing, send a post card to:

THE HOUSE OF MINIATURES
Customer Service - Parts Dept.
147 Lake Street
Delaware, OH 43015

Please print Name, Address, Part Number (Number from Layout Sheet) and Kit Name and Number on card when ordering.

SANDING

Before assembly, sand all the outer surfaces of individual parts with 220 grit sandpaper, or finer, sanded in the same direction as the wood grain until the surface is smooth. Take care not to round any edges or corners of the pieces. Finish sanding with 280 grit sandpaper.

PRE-ASSEMBLY

A. After sanding, check the proper location and fit of each part by assembling parts loosely, without gluing. Use the **DETAIL VIEWS** as a guide.

B. All parts for X-ACTO kits are made on precision milling machines. When adjustments are required, sand to fit.

TOOLS AND MATERIALS

A. The following tools will be helpful in constructing this kit:

1. Two-inch Sander, X-ACTO No. 7042
2. Small Clamp, X-ACTO No. 7003
3. X-ACTO Professional Finishing Kit (or equivalent, see note)

B. The following materials will be needed to construct this kit:

1. X-ACTO Tinted Glue (see note)
2. Sandpaper - 220 and 280 grit
3. Steel Wool - Grade 0000
4. Small Artist's Brush

NOTE: The X-ACTO tinted glue is matched to the finish used in the Professional Finishing Kit. This will produce the authentic finish of the period in which the original Furniture was produced. When not using X-ACTO glue follow manufacturer's directions.

GLUING

A. Glue should be applied in small amounts to surface being joined. When gluing dado joints apply glue to dado only.

B. To ensure a tight fit, squeeze excess glue out of the joints. Hold glued parts together with clamps, rubber bands or weights on the parts.

C. Wipe off excess glue promptly.

D. Be sure a glued assembly has dried thoroughly before adding parts.

FINISHING

The X-ACTO Professional Finishing Kit enables you to finish your furniture by the same process used by the professional furniture maker. The end result is what is important — there are easier methods, but none that will give the quality results that this process will. If you use a finish other than X-ACTO's, refer to the manufacturer's directions.

Detail Views

Kit 40049

Layout Sheet

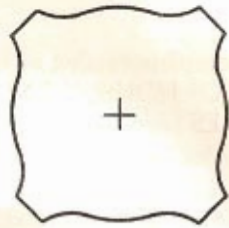

96



26
(6 REQ'D)



33
(2 REQ'D)

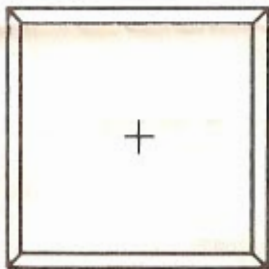

95

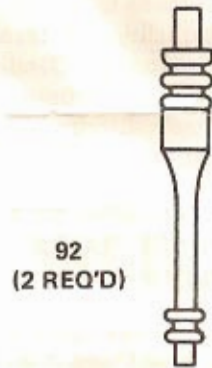

92
(2 REQ'D)

NOTE: Parts included for 2 candlestands.

Step 1

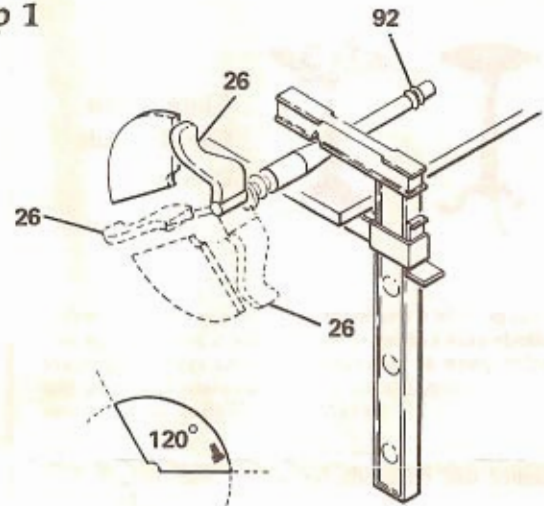

A. Glue on leg (26) to long projection on the pedestal. Allow glue to set, then using the 120° guide for proper spacing, glue on other two legs.

B. Repeat for second pedestal.

Step 2

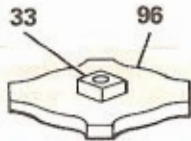

A. Center and glue mounting block (33) on top (96).

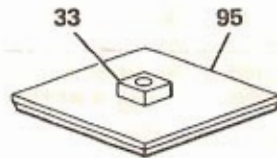

B. Center and glue mounting block on top (95). Shaped edge should face up when completed.

Step 3

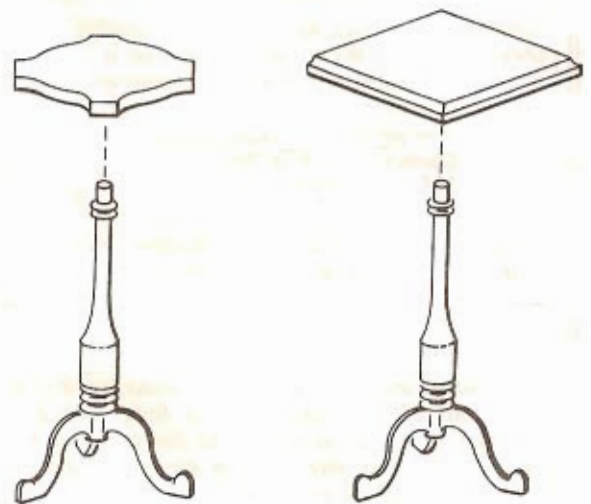

A. Glue tops to pedestals. Check that they are level before glue sets.

B. Apply final finish.