

## COLLECTORS NO. 40039



Queen Anne  
Tea Table

Circa 1740-1750

This was a very popular design in its period and as an antique is highly prized today. Versions of this table have been reproduced almost continually since the inception of the design and are listed in the current catalogs of many furniture manufacturers.

It is also referred to as a Tray-Top Table due to the deep molded top edge which gives it a tray like appearance. Although it was primarily used as a Tea Table many other uses were found for it in the colonial time.

Its graceful cabriole legs were either left plain or were decorated with shell carvings on the knees. The skirt was either plain, or molded as in our version. Other versions also had a scroll balanced lower edge.

Pull out candle shelves at each end are found on some, and some very rare versions had a shallow drawer on the side.

The English versions were almost exclusively constructed of mahogany, while walnut and curly maple were widely used here.

## ASSEMBLY AND FINISHING INSTRUCTIONS



AUTHENTIC REPRODUCTIONS IN MINIATURE

The X-ACTO® House of Miniatures Collectors Series® of furniture and accessories have all been carefully researched by specialists through major museum and library collections to assure the highest quality of authenticity in reproduction. Details are extraordinarily accurate to satisfy the most discriminating miniaturist.

All wood parts are machined to assure accurate and precise acceptance of each piece by another.

For a complete catalog of the X-ACTO® HOUSE OF MINIATURES furniture line and accessories, write to:

X-ACTO® THE HOUSE OF MINIATURES Dept. KIT  
45-35 Van Dam Street  
Long Island City,  
New York 11101

*Please include \$2.00 for postage and handling.*

### TOOLS AND MATERIALS

A. The following tools will be helpful in constructing this kit:

1. Two-inch Sander, X-ACTO No. 7042
2. Small Clamp, X-ACTO No. 7003
3. X-ACTO Professional Finishing Kit (or equivalent, see note)

B. The following materials will be needed to construct this kit:

1. X-ACTO Tinted Glue (see note)
2. Sandpaper - 220 and 280 grit
3. White glue (or equivalent)
4. Small Artist's Brush

**NOTE:** The X-ACTO tinted glue is matched to the finish used in the Professional Finishing Kit. This will produce the authentic finish of the period in which the original Furniture was produced. When not using X-ACTO glue follow manufacturer's directions.

### GLUING

A. Glue should be applied in small amounts to surface being joined. When gluing dado joints apply glue to dado only.

B. To ensure a tight fit, squeeze excess glue out of the joints. Hold glued parts together with clamps, rubber bands or weights on the parts.

C. Wipe off excess glue promptly.

D. Be sure a glued assembly has dried thoroughly before adding parts.

### FINISHING

The X-ACTO Professional Finishing Kit enables you to finish your furniture by the same process used by the professional furniture maker. The end result is what is important — there are easier methods, but none that will give the quality results that this process will. If you use a finish other than X-ACTO's, refer to the manufacturer's directions.

## INTRODUCTION

### BEFORE STARTING

Identify and account for each part by placing it on the Layout Sheet (make sure the correct layout sheet is used when working on multi-kit Instruction Sheets). Should any parts be missing, send a post card to:

X-ACTO/The House of Miniatures  
45-35 Van Dam Street  
Long Island City, N.Y. 11101

Please print Name, Address, Part Number (Number from Layout Sheet) and Kit Name and Number on card when ordering.

### SANDING

Before assembly, sand all the outer surfaces of individual parts with 220 grit sandpaper, or finer, sanded in the same direction as the wood grain until the surface is smooth. Take care not to round any edges or corners of the pieces. Finish sanding with 280 grit sandpaper.

### PRE-ASSEMBLY

A. After sanding, check the proper location and fit of each part by assembling parts loosely, without gluing. Use the **DETAIL VIEWS** as a guide.

B. All parts for X-ACTO kits are made on precision milling machines. When adjustments are required, sand to fit.



# Layout Sheet

KIT 40039

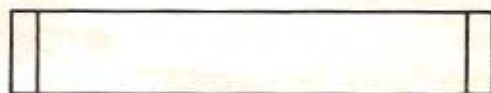

0 (2 REQ'D)

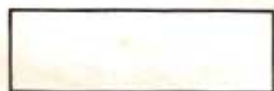

1 (2 REQ'D)

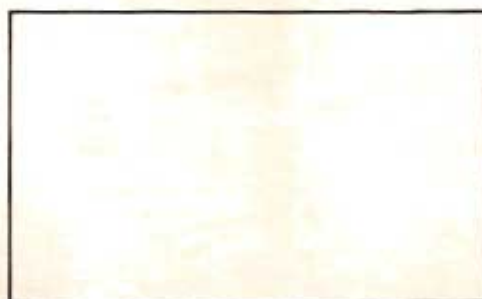

99



2 (2 REQ'D)

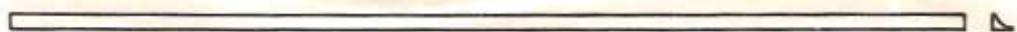

26 (2 REQ'D)

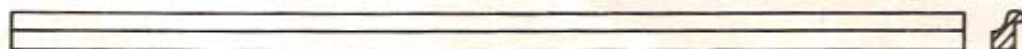

98 (2 REQ'D)



24  
(4 REQ'D)

## Step 1

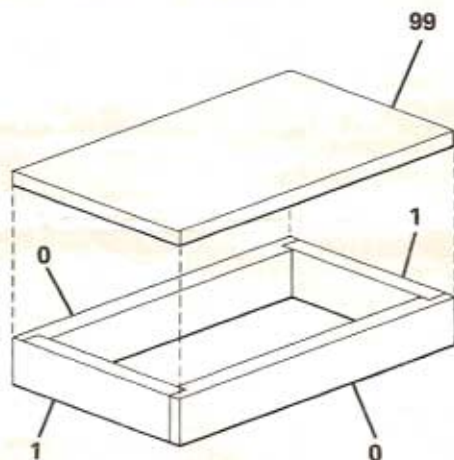

**NOTE:** Ensure all edges are properly aligned before glue sets.

A. Glue right and left sides (1) to front and rear (0).

B. Glue top (99) to assembled sides. Ensure all edges are flush.

## Step 2

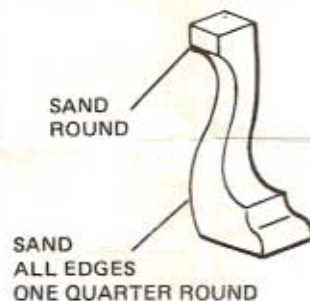

FINISHED SHAPED LEG

**NOTE:** Cabriole legs (6) may be shaped prior to assembly.

A. Shape legs by sanding.

B. Sand base of leg until it is round.

# Detail Views

KIT 40039

## Step 3

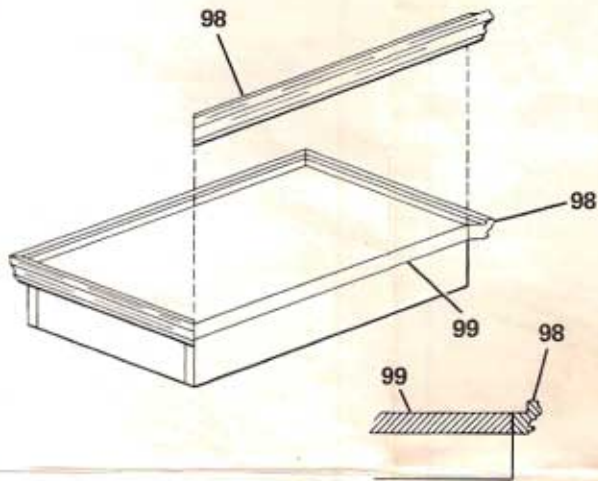

A. Miter cut two pieces of Outside Molding (98) 2 1/2 inches long and two pieces 1 1/2 inches long.

B. Glue molding (98) flush with top (99).

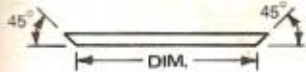

## Step 4

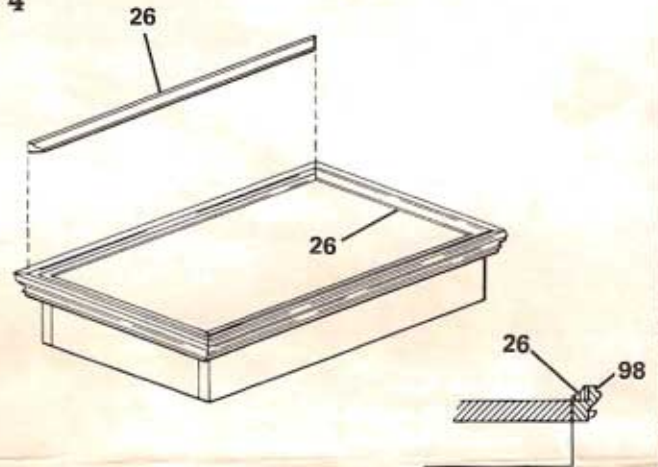

NOTE: The molding in this step is Inside Molding and dimensions are given from outside measurements.

A. Miter cut two pieces of inside 1/16" cove molding (26) 2 1/2 inches long and two pieces 1 1/2 inches long.

B. Glue molding (26) to inside lip of molding (98).

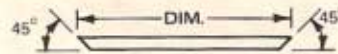

## Step 5

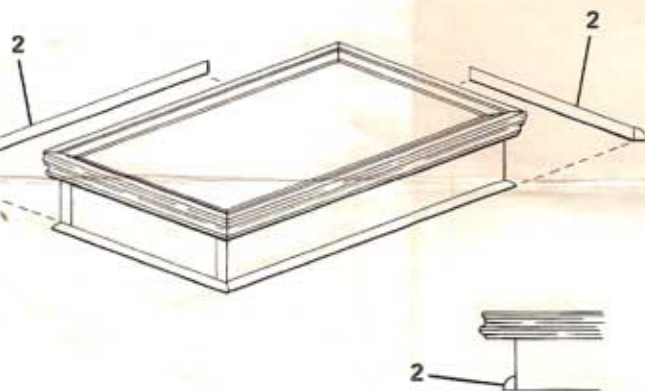

A. Miter cut two pieces of 1/4" round molding (2) 2 1/2 inches long and two pieces 1 1/2 inches long.

B. Glue molding (2) to bottom edge of sides.

NOTE: The molding we will be assembling in this step is Outside Molding. Outside Molding dimensions are all given from inside point to inside point and shall be cut at 45° angles.

## Step 6

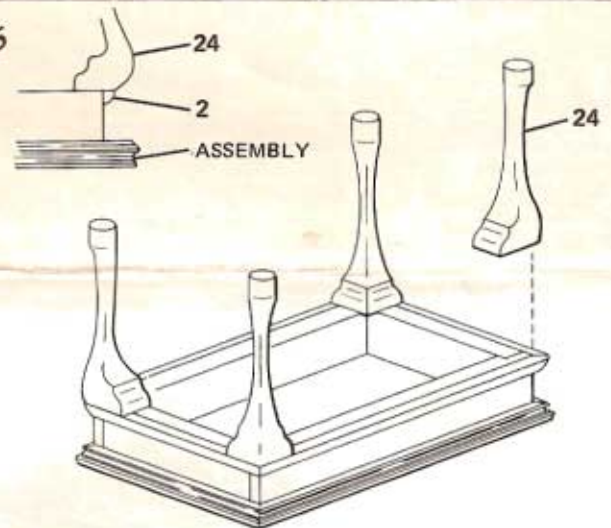

NOTE: Turn assembly upside down and place on a clean flat surface.

A. Glue legs (24) to bottom of assembly keeping outside edges of legs flush with molding (2).

NOTE: Refer to Final Finishing.