

## COLLECTORS NO. 40014



Chippendale  
Canopy Bed  
Circa 1750-1790

This type bed was also known as a "bedstead", meaning wooden frame with mattress. Although a few high-post bedsteads in the Queen Anne style have been found in our country, the story of fine American bedsteads really begins at about 1735 with those having square block feet or ball and claw feet in the Chippendale style. The high-post bedstead became an article of elegance in our country, as it was in England, with the increase in wealth and the building of fine houses. The wood used in finer bedsteads in America was generally mahogany.

Since there were no commercial springs available for beds, it was common practice to have rope springs which were strung in both directions giving firm support for the straw (or) down feather filled mattress. This bed has square legs, terminating in square block feet, not tapered, which at first sight may appear to be tapered spade feet such as were used by Hepplewhite and Sheraton on side boards and other pieces. The foot-posts were fluted, but the head-posts were plain columns. All the posts were slightly tapered.

The canopy curtain and foot skirt were commonly covered with matching design of the wall covering. The fabric design was also found in drapery material giving this classic bed an elegance of the colonial sleeping salon.

## ASSEMBLY AND FINISHING INSTRUCTIONS



AUTHENTIC REPRODUCTIONS IN MINIATURE

The X-ACTO® House of Miniatures® Collectors Series of furniture and accessories have all been carefully researched by specialists through major museum and library collections to assure the highest quality of authenticity in reproduction. Details are extraordinarily accurate to satisfy the most discriminating miniaturist.

All wood parts are machined to assure accurate and precise acceptance of each piece by another.

For a complete catalog of the X-ACTO® HOUSE OF MINIATURES furniture line and accessories, write to:

X-ACTO® THE HOUSE OF MINIATURES Dept. KIT  
45-35 Van Dam Street  
Long Island City,  
New York 11101

Please include \$1.00 for postage and handling.

## INTRODUCTION

### BEFORE STARTING

Identify and account for each part by placing it on the Layout Sheet (make sure the correct layout sheet is used when working on multi-kit Instruction Sheets). Should any parts be missing, send a post card to:

X-ACTO/The House of Miniatures  
45-35 Van Dam Street  
Long Island City, N.Y. 11101

Please print Name, Address, Part Number (Number from Layout Sheet) and Kit Name and Number on card when ordering.

### SANDING

Before assembly, sand all the outer surfaces of individual parts with 220 grit sandpaper, or finer, sanded in the same direction as the wood grain until the surface is smooth. Take care not to round any edges or corners of the pieces. Finish sanding with 280 grit sandpaper.

### PRE-ASSEMBLY

A. After sanding, check the proper location and fit of each part by assembling parts loosely, without gluing. Use the DETAIL VIEWS as a guide.

B. All parts for X-ACTO kits are made on precision milling machines. When adjustments are required, sand to fit.

### TOOLS AND MATERIALS

A. The following tools will be helpful in constructing this kit:

1. Two-inch Sander, X-ACTO No. 7042
2. Large Clamp, X-ACTO No. 7004
3. Small Clamp, X-ACTO No. 7003
4. X-ACTO Professional Finishing Kit (or equivalent see note)

B. The following materials will be needed to construct this kit:

1. X-ACTO Tinted Glue (see note)
2. Sandpaper -220 and 280 grit
3. Steel Wool - Grade 0000
4. Small Artist's Brush

**NOTE:** The X-ACTO tinted glue is matched to the finish used in the Professional Finishing Kit. This will produce the authentic finish of the period in which the original Furniture was produced. When not using X-ACTO glue follow manufacturer's directions.

### GLUING

A. Glue should be applied in small amounts to surface being joined. When gluing dado joints apply glue to dado only.

B. To ensure a tight fit, squeeze excess glue out of the joints. Hold glued parts together with clamps, rubber bands or weights on the parts.

C. Wipe off excess glue promptly.

D. Be sure a glued assembly has dried thoroughly before adding parts.

### FINISHING

The X-ACTO Professional Finishing Kit enables you to finish your furniture by the same process used by the professional furniture maker. The end result is what is important - there are easier methods, but none that will give the quality results that this process will. If you use a finish other than X-ACTO's, refer to the manufacturer's directions.

# Detail Views

Kit 40014

## Step 3

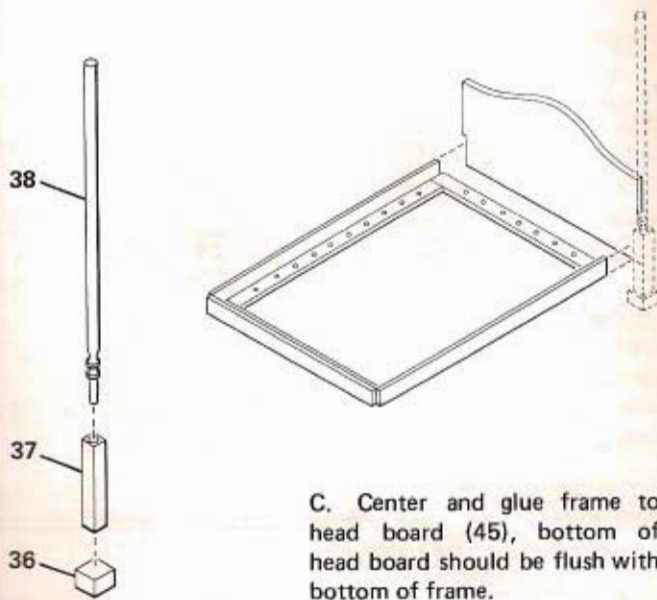

Center corner post (37) on lock foot (36) and glue.

Apply small amount of glue to small end of post (38) and insert into corner post (37). Repeat for remaining three posts.

C. Center and glue frame to head board (45), bottom of head board should be flush with bottom of frame.

D. Position each corner post against the head board making certain post is placed tightly against frame and notch in headboard. Mark each post at bottom of headboard with a pencil.

## Step 4

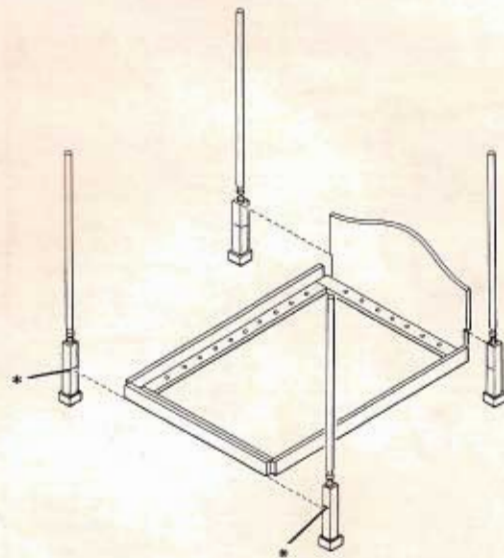

A. Glue two posts to headboard. Posts should be against the frame and up against the notch in the headboard. Check vertical alignment of each post.

B. Position two posts at foot of bed. Using marks made in Step 3 align marks (\*) at bottom of frame. Glue post into notches of each corner. Check vertical alignment of each post.

## Step 5

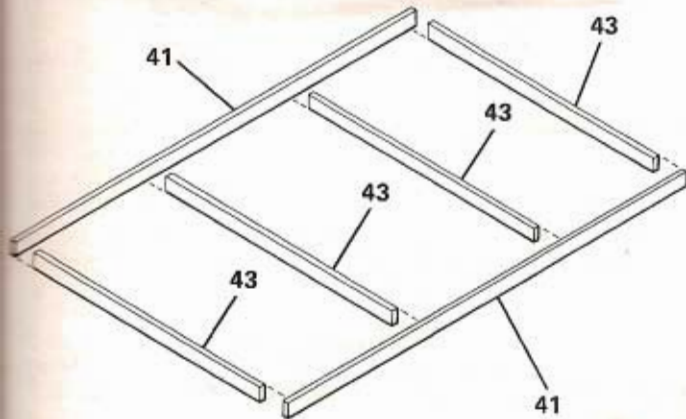

Assemble canopy frame utilizing Alignment Pattern 3.

With canopy frame still on Alignment Pattern turn assembled bed upside down.

C. Glue posts to frame corners. Pin in place until glue sets.

D. Refer to Final Finishing before proceeding to Step 6.

## Step 6

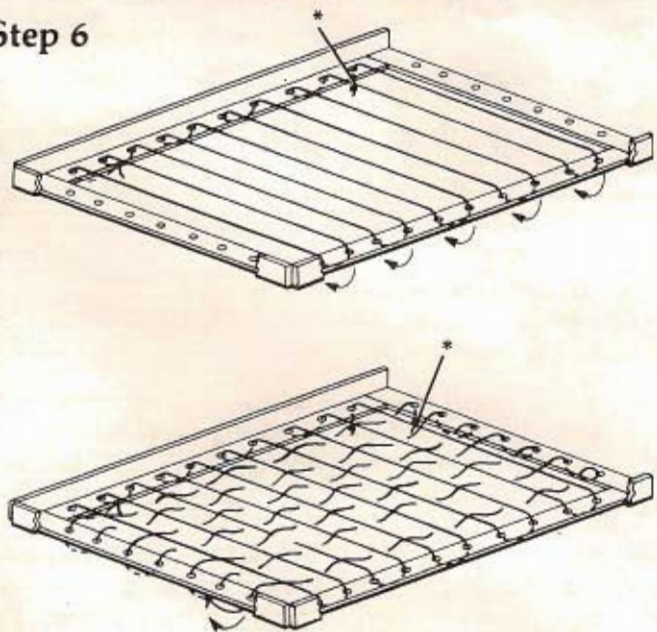

NOTE: For ease of stringing, dip one end of string in glue, wipe off excess and allow to dry.

A. Tie knot (\*) in other end of string. Reeve glued tip back and forth across frame, keeping

string tight. Tie off end of string with knot.

B. Repeat Step A, stringing in opposite direction, weaving string over and under string installed in Step A.

C. Install foam mattress (31).

# Layout Sheet

Kit 40014

41 (2 REQ'D)

31 (FOAM MATTRESS)

39 (2 REQ'D)

44 (2 REQ'D)

38 (4 REQ'D)

STRING

37 (4 REQ'D)

36 (4 REQ'D)

40 (3 REQ'D)

43 (4 REQ'D)

45

## Step 1

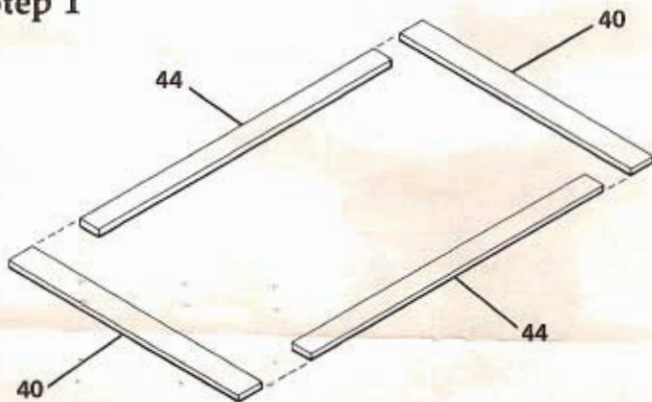

A. Utilizing Alignment Pattern No. 1, glue ends (40) to sides (44).

B. After glue sets, drill holes for string with a No. 52 drill bit utilizing Alignment Pattern No. 1.

## Step 2

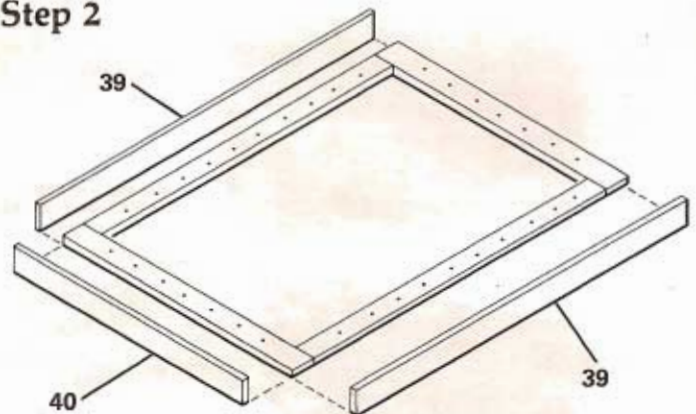

A. Utilizing Alignment Pattern No. 2, glue side rails (39) and footboard (40) to frame assembly.

# Alignment Pattern

Kit 40014

This Alignment Pattern to be used with Steps 1 and 2.

(Sheet 1 of 2)

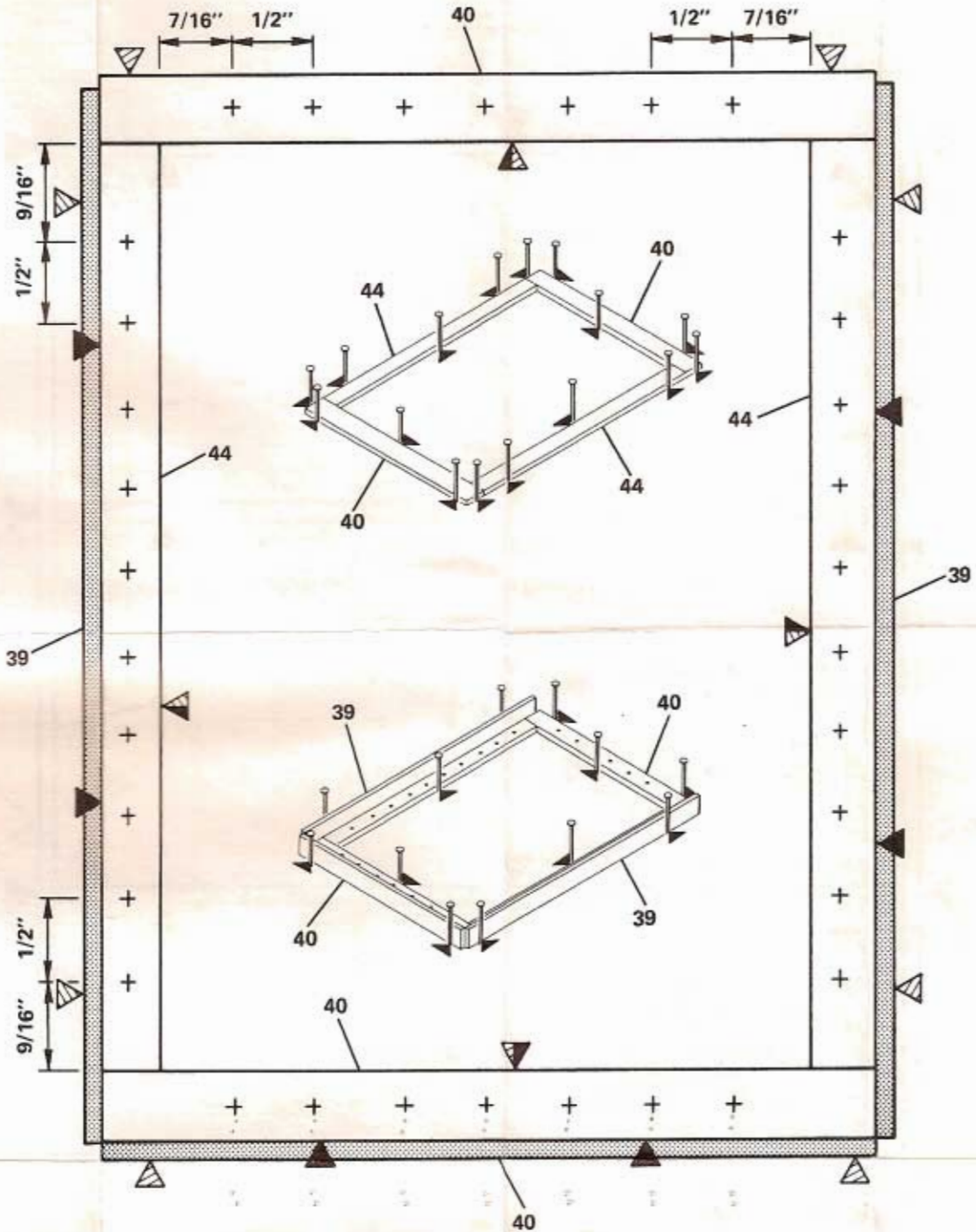

-  ALIGNMENT PATTERN NO. 1
-  ALIGNMENT PATTERN NO. 2

# Alignment Pattern

Kit 40014

This Alignment Pattern to be used with Step 6 (fold over during assembly).

(Sheet 2 of 2)

Alignment Pattern No. 3

