

## COLLECTORS NO. 40011



**Chippendale  
Three Drawer Chest**  
Circa 1750-1790

Thomas Chippendale, the best known and best advertised figure in the history of furniture making, was born about 1705.

Few furniture designers become influential enough to have their names rather than a monarch's linked with current styles. One of these was Thomas Chippendale, who operated one of the most fashionable shops in London from 1745 until his death in 1777, after which his son, known as Thomas Chippendale the younger, continued the business into the 1790's. During the years in which the Chippendale prevailed in America from about 1755-1785, practically all of our furniture of the better sort was made in that style. The style continued for some time after it was supplanted in England by new styles. This occurred because of the Revolutionary War which stopped business relations between the two countries for several years. The American cabinet makers, not having the new styles, continued in the Chippendale tradition.

This three drawer chest was often referred to as a "bureau" which was used to hold clothing and storage of bedding and extra soft goods. The Chippendale three drawer chest is of the "straight front flat top" design with bracket feet. Each drawer had a lock. The chest was a large piece found in sleeping salons, hallways and ante rooms.

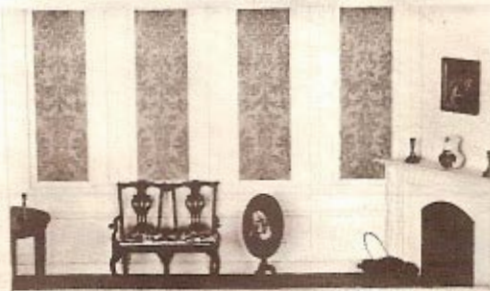

## ASSEMBLY AND FINISHING INSTRUCTIONS



**AUTHENTIC REPRODUCTIONS IN MINIATURE**

The CRAFTMARK House of Miniatures Collectors Series of furniture and accessories have all been carefully researched by specialists through major museum and library collections to assure the highest quality of authenticity in reproduction. Details are extraordinarily accurate to satisfy the most discriminating miniaturist.

Every item in the line is an authentic reproduction in miniature of regular-size furniture created by master craftsmen during the Colonial period, precision scaled, one inch to one foot.

All wood parts are machined to assure accurate and precise acceptance of each piece by another.

The rooms illustrated have been completed using standard CRAFTMARK HOUSE OF MINATURES products. All individual components are available.

For a complete catalog of the CRAFTMARK HOUSE OF MINATURES furniture line and accessories, write to:

CRAFTMARK/ HOUSE OF MINATURES  
Customer Service Catalog Dept.  
147 Lake Street  
Delaware, Ohio 43015

*Please include \$2.00 for postage and handling.*

# INTRODUCTION

## INSTRUCTIONS BEFORE STARTING

### before starting

A. Identify and account for each part by placing it on the **LAYOUT SHEET** (Page 2). This will indicate, at a glance, whether any parts are missing. **(See instructions at bottom of last sheet to order missing parts.)**

B. The **LAYOUT SHEET** contains a hardware check list. Use this to identify and account for all hardware that comes with the kit.

### sanding

**NOTE:** When using sandpaper, remember that the higher the grit number, the finer the finish.

A. One sanding method that has proved successful is the use of a sanding platform. Tape a sheet of sandpaper of the proper grit size to a hard flat surface such as a table top or wood block. Press down **lightly** and move the piece to be sanded **in the same direction** as the wood grain until the surface is smooth. **Take care not to round any edges or corners of the pieces.**

B. Before assembly, sand all the outer surfaces of individual parts with 220 grit sandpaper, or finer, paying particular attention to edges that will be exposed after assembly. After sanding each piece thoroughly, finish sanding with 400 grit sandpaper. Remember, your final stained finish will only be as smooth as the surface under it.

### hardware

A. All hardware to complete this kit is provided. Installation holes for all hardware must be made in accordance with the **ASSEMBLY** instructions that follow. Use the **DETAIL VIEWS** (Page 3) for hole locations.

B. Do not force handle into holes in handle plate. If a hole is too small, enlarge it slightly with a small knife or needle file.

C. Do not install brass hardware until final finishing has been done to avoid staining hardware.

### gluing

A. Glue should be applied in small amounts to both surfaces being joined. On end cuts, it may be necessary to apply a second coat of glue before joining the parts.

B. To ensure a tight fit, squeeze excess glue out of the joints by holding glued parts together with either clamps, rubber bands or by placing weights on the parts.

C. Wipe off excess glue promptly with a damp cloth.

D. Be sure a glued assembly has dried thoroughly before adding any more parts.

### tools and materials

A. The following tools **will be helpful** in constructing this kit:

1. Knife
2. Tweezer
3. One-inch Sander
4. Two-inch Sander
5. Large Clamp
6. Small Clamp
7. Swiss Needle File Set
8. Professional Finishing Kit
9. Power Sprayer

B. The following materials **will be needed** to construct this kit:

1. Straight pins or artist's push pins
2. Rubber bands
3. Waxed paper
4. Sandpaper - 220, 320, and 400 grit
5. Steel wool - Grade 000
6. Masking tape
7. Ruler
8. Wood stain of your choice. **(See Note)**
9. Glaze stain of your choice. **(See Note)**
10. Lacquer or varnish of your choice. **(See Note)**
11. White glue, or any good wood glue. **(See Note)**
12. Sealer **(See Note)**
13. Small Artist's Brush

**NOTE:** The CRAFTMARK No. 43801 Professional Finishing Kit will produce the authentic Mahogany finish of the period in which the original furniture was produced. Base stain, glaze stain, lacquer or varnish, sealer and glue are required only if the CRAFTMARK Professional Finishing Kit is not used.

### pre-assembly

A. After sanding, check the proper location and fit of each part by assembling parts loosely, without gluing. Use the **DETAIL VIEWS** (Page 3) as a guide.

B. Parts can be held together to check proper fit with rubber bands or masking tape.

C. All parts for CRAFTMARK kits are made on precision milling machines, using rabbet and dado joints. Parts will fit together snugly with very little adjustments required. When adjustments are required, sand or file to fit.

# LAYOUT SHEET

22 (3 REQ'D)

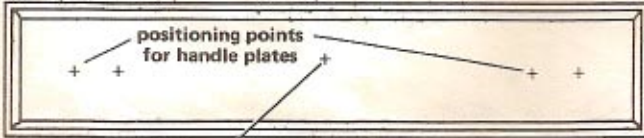

positioning for keyhole plate

23 (3 REQ'D)

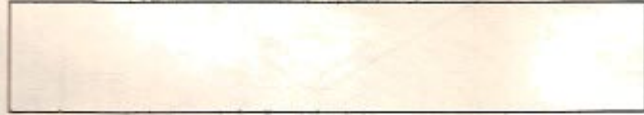

24 (6 REQ'D)

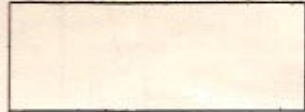

25 (3 REQ'D)

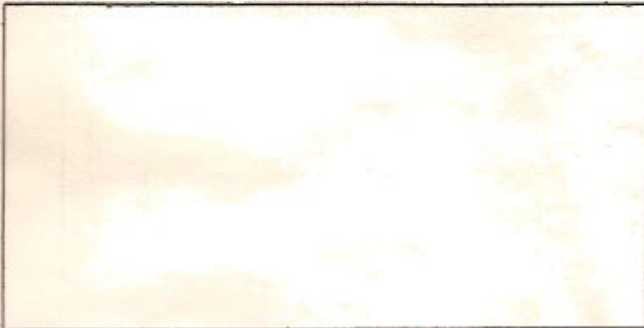

26



27 (6 REQ'D)

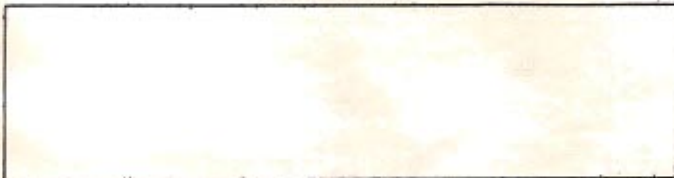

31

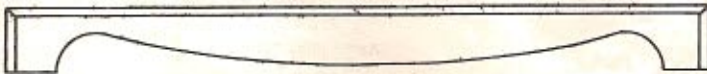

28



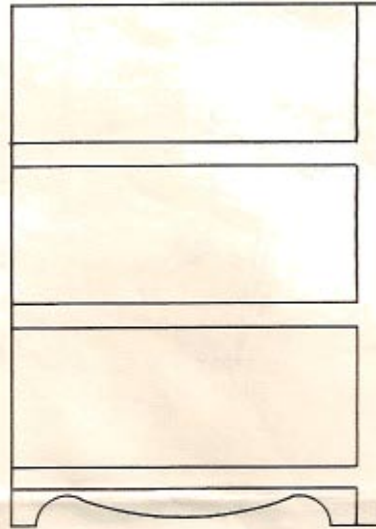

29

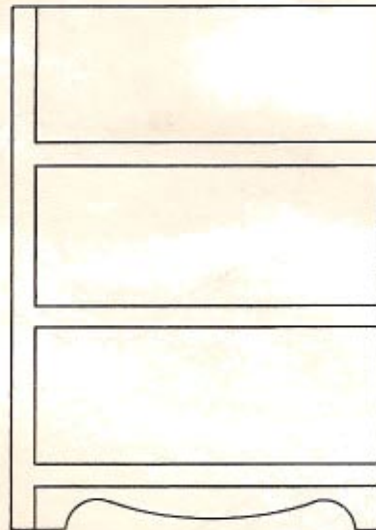

30



## HARDWARE CHECK LIST

DESCRIPTION	VISUAL DESCRIPTION	QTY
HANDLE PLATE		6
HANDLE		6
KEYHOLE PLATE		3

# DETAIL VIEWS

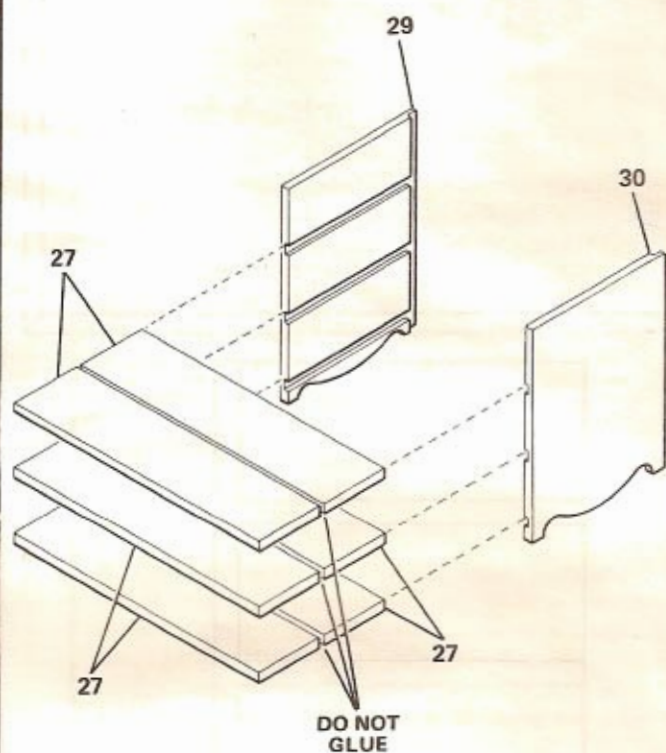

**DETAIL A**

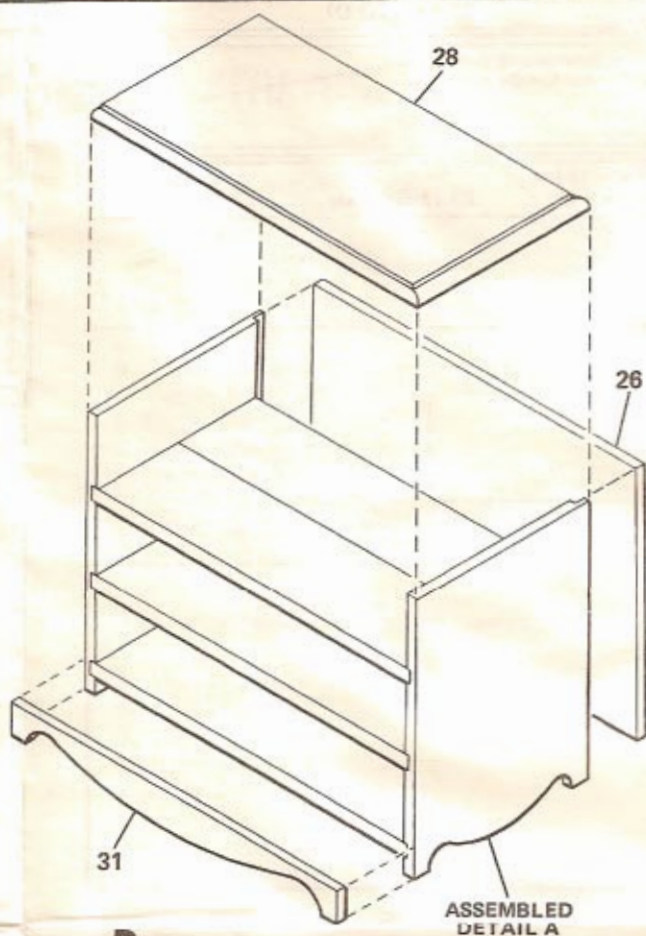

**DETAIL B**

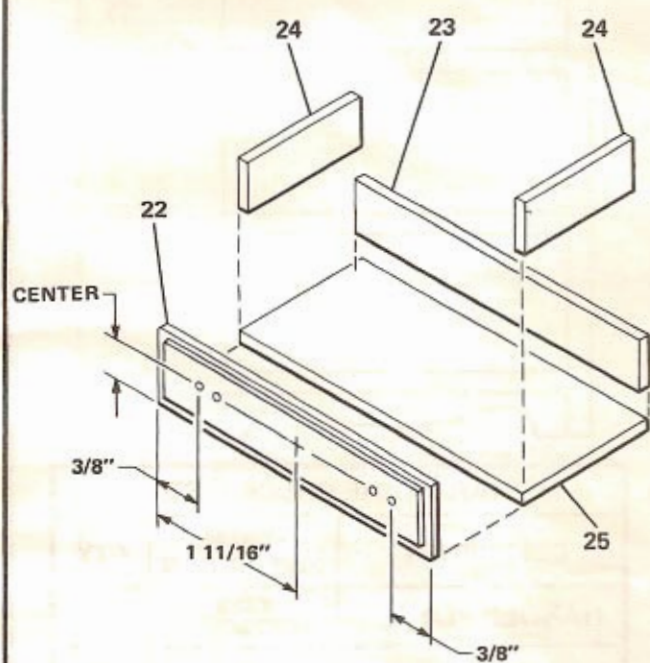

**DETAIL C**

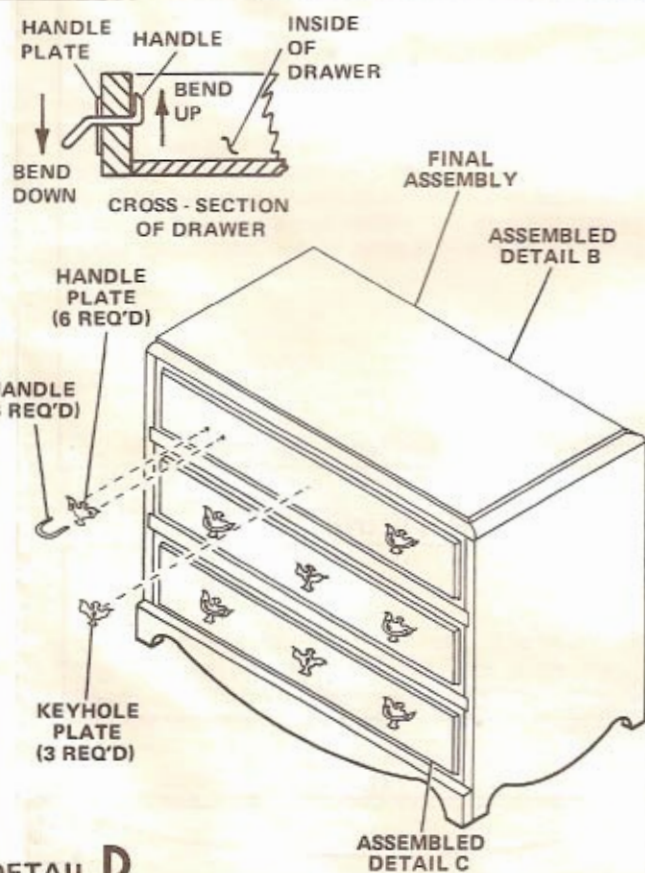

**DETAIL D**

# ASSEMBLY

A. Before starting to assemble your kit, study all illustrations and instructions carefully. Be certain you understand each step before proceeding to the next one.

B. Follow the sequence of steps in the order they are presented. Do not skip steps or take any short cuts.

C. Refer to **ALIGNMENT** (page 5) for pattern to be used to align the frame for gluing. When gluing parts together, use a flat toothpick or similar tool to apply a small amount of glue to the parts to be joined. Remove any excess glue promptly with a damp cloth. Remember to let each glued assembly dry thoroughly before adding the next part.

D. The Professional finishing Kit, CRAFTMARK No. 43801, will produce the authentic Mahogany finish of this period and contains a **matching tinted glue**, is recommended for assembly of this kit. The **tinted glue** is of furniture grade quality, equivalent to that used by professional cabinet makers and its use will avoid the appearance of a glue line at each joint.

E. Begin assembly of the **frame** (see **DETAIL A**, page 3) as follows:

1. Glue two shelves (part no. 27) into each groove of side (part no. 29). Position each shelf so that front edge of front shelf is flush with front edge of side and that both shelves in each groove are butted together tightly.

**( DO NOT GLUE PARTS 27 TOGETHER )**

2. Carefully insert and glue exposed edges of shelves into grooves of remaining side (part no. 30). Again make sure that front edge of each front shelf is flush with front edge of side and that both shelves in each groove are butted together tightly.

3. Place assembly face down on alignment **pattern** (see **ALIGNMENT**, page 5). Press back (part no. 26) in position but **do not glue**. This will help to align parts until glue sets.

4. Use clamps or several rubber bands to hold parts in place until glue sets. (Follow the instructions for the glue being used for the proper setting time.)

F. Complete assembly of frame (see **DETAIL B**, page 3) as follows:

1. Glue back (part no. 26) to rear of sides and rear edges of back shelves.

2. Glue top (part no. 28) to top edges of sides and back.

3. Glue bottom trim (part no. 31) to front edges of sides and lower shelf.

G. Assemble **drawers** (see **DETAIL C**, page 3) as follows:

1. Using dimensions shown, locate a handle plate at the proper position on a drawer front (part no. 22). Mark the positions of the handle holes with a straight pin or an artist's push pin.

2. Using the straight pin or the push pin, make through-holes at the marked positions.

3. Repeat this procedure for five additional sets of handle holes.

4. Brass hardware will be installed at these positions as a final step.

5. Glue drawer back (part no. 23) and two drawer sides (part no. 24) to drawer bottom (part no. 25), as shown.

6. Glue drawer front (part no. 22) to front edges of drawer sides and bottom.

7. Repeat this procedure for two remaining drawers.

H. You have now completed assembly of your furniture, except for the installation of brass hardware. Refer now to **FINAL FINISHING** for final finishing instructions. **Then continue with ASSEMBLY paragraph I**, for installation of hardware.

**NOTE:** For authenticity, when finishing drawers, finish only the drawer fronts.

I. Install brass hardware on drawers (see **DETAIL D**, page 3) as follows:

1. Insert a handle through holes in handle plate. Apply a small amount of glue to the back of the handle plate and insert ends of handle through holes in drawer front as shown. Bend up ends of handles on back surface of drawer front and bend down front of handles. (see **DETAIL D** page 3)

2. Repeat this procedure for five remaining handles and plates.

3. Apply a small amount of glue to the back of a keyhole plate and install at marked position on drawer front, as shown.

4. Repeat this procedure for two remaining keyhole plates.

J. You have now completed assembly of your furniture. The completed piece should look like that shown in **DETAIL D**, (page 3).

## FINAL FINISHING

In order to ensure that your piece is stained and highlighted in the tones of the period in which the original furniture was produced, we recommend that **CRAFTMARK Professional Finishing Kit, No. 43801** be used. The following method is used by professional furniture makers, and, if done properly, will result in museum quality.

A. After assembly is completed and the glue has set, **lightly** sand all joint areas to remove excess glue, using 220 grit sandpaper or finer. Moisten a cloth slightly and rub the dampened cloth over the entire wood surface to raise the grain. When all signs of moisture have gone from the wood, resand using a 320 to 400 grit sandpaper.

B. With a small brush, apply a light sealer coat to all edges and end grains. Use the side of the brush rather than the tip, in a wiping motion, so that the sealer does not touch other surfaces. Sealing the edge and end grains will prevent the subsequent stain from penetrating these areas as deeply, resulting in a more uniform stain on all parts.

**NOTE:** If the **CRAFTMARK** Finishing Kit (which contains a high quality sealer) is not used, thinned varnish or lacquer can be used for this purpose.

C. To match the color of furniture of this period apply **CRAFTMARK Base Stain** or mahogany or cherry stain of your choice with a brush or cloth over the entire wood surface. Immediately wipe off all excess stain leaving an even color on the surface. Allow to dry.

D. Apply a thin coat of **CRAFTMARK Sealer** or any commercial wood sealer over the base stain. This can be applied with either a brush or with the **CRAFTMARK Power Sprayer**. Make sure there are no drip marks present. Allow the sealer to dry for at least 6 hours.

**CRAFTMARK POWER SPRAYER** No. 43561 can be used to apply sealer, top coat, and paint for outstanding results. This spray ensures application of an even coat, especially on intricate and flat surfaces, and it is highly recommended for finishing your furniture.

E. Lightly go over all surfaces with Grade 000 steel wool until they are smooth to the touch.

F. **"Highlighting"** is a technique of creating light and dark areas and is accomplished by applying the **CRAFTMARK Glaze Stain** or any commercial glaze stain of your choice (Van Dyck Brown is the color recommended) and then toning by rubbing off the glaze in certain areas, exposing the base stain. In order to "highlight", apply a dark glaze with a brush or rag over the entire piece of furniture. As soon as you have applied this glaze, wipe off the excess. Blend tones of base color and glaze stain by using a piece of soft cloth. There should never be a sharp line of dark color to light color but rather a smooth blending effect. Lighten the middle surface of the wood, but do not lighten the entire surface. The **"highlighting"** technique will produce museum quality miniature furniture.

G. After the glaze stain has dried for 24 hours, thoroughly and briskly wipe all surfaces with a clean cloth until you are satisfied with the appearance. Apply the **CRAFTMARK Top Coat** or a coat of lacquer or varnish, with a brush, an airbrush, or with the **CRAFTMARK Power Sprayer**. Apply two or more top coats with light buffing between coats using Grade 000 steel wool. After each steel wool rubbing make sure all steel wool "dust" is removed thoroughly. **(Continue with ASSEMBLY starting with paragraph I).**

# ALIGNMENT

A. Tape this sheet to a smooth, flat surface. Then tape sheet of waxed paper to the pattern so that any excess glue at the joint will not stick to the pattern, making it difficult to remove the completed assembly.

B. Use the alignment pattern shown here to position the indicated parts properly and to hold them in alignment while drying.

## alignment pattern

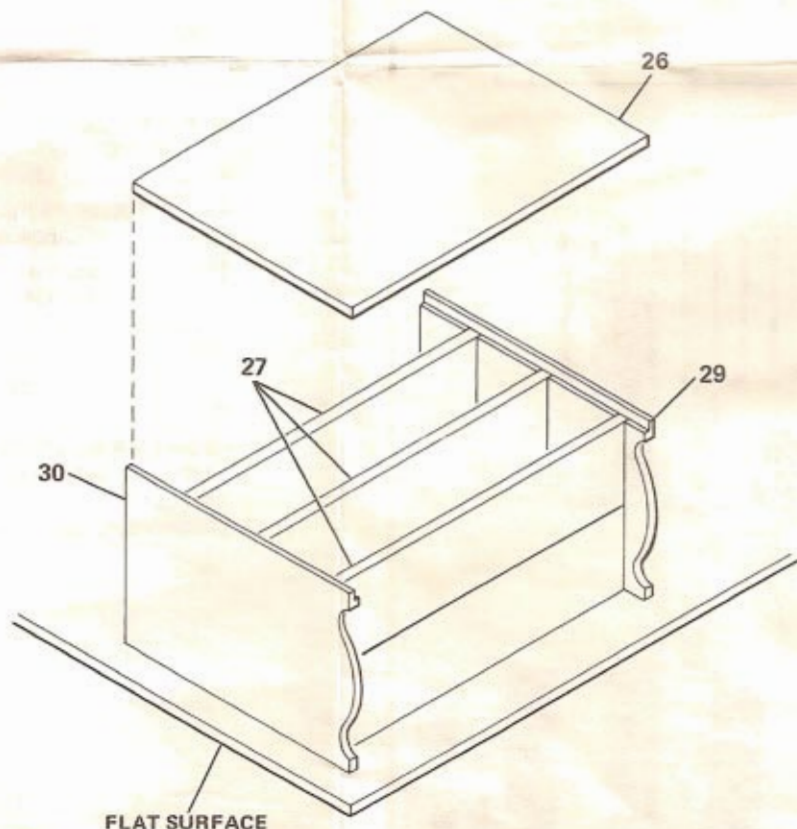
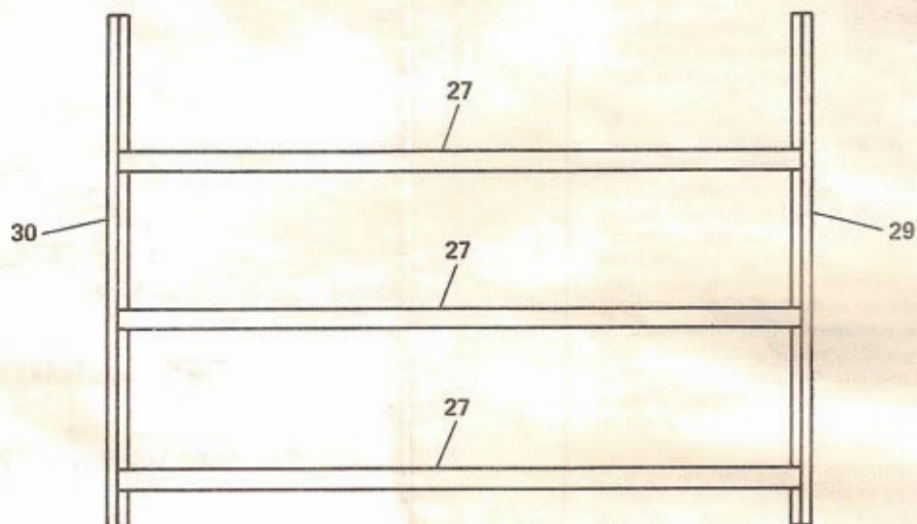

Every effort has been made to insure the completeness of this KIT - however, should any parts be missing, write directly to:  
CRAFTMARK/THE HOUSE OF MINIATURES  
147 Lake Street  
Delaware, Ohio



When ordering missing parts, please Print your name and address plainly. State the missing PART NO. (See LAYOUT SHEET, page 2), KIT NO. 40011 and the Kit Name, "CHIPPENDALE THREE DRAWER CHEST".