

40006C

COLLECTORS NO. 40006

Hepplewhite Three Piece Dining Room Table
 Circa early 1800's



Elegance and gracefulness sum up the appearance of furniture inspired by George Hepplewhite's designs. Elegance was inherent in the rich mahogany while gracefulness was achieved by square tapering legs and oval tops on tables. Hepplewhite's style dominated the early years of the federal furniture period in the United States. This being the decade after the Revolutionary War which reflected the pride of Americans in their new and growing nation.

Hepplewhite style dining tables are chiefly found in the South, especially in Maryland. These dining tables are of mahogany.

The inlaid decorations of these tables are very pleasing. The areas where decoration was commonly used were on the surface under the top, called the "skirt" or "apron" or "frieze", and on the legs. At these places the inlaid forms of the Hepplewhite period are seen. Some of the dining tables in this style are without decoration of any kind. The legs are square, straight and tapered as on the sideboards and card tables in the Hepplewhite style about 1785-1800. Today a faithful reproduction of this Hepplewhite table can be seen in the Daphne Room of the Raleigh Tavern in Williamsburg.

ASSEMBLY AND FINISHING INSTRUCTIONS



AUTHENTIC REPRODUCTIONS IN MINIATURE.

The HOUSEWORKS LTD House of Miniature Collectors Series of furniture and accessories have all been carefully researched by specialists through major museum and library collections to assure the highest quality of authenticity in reproduction. Details are extraordinarily accurate to satisfy the most discriminating miniaturist.

Every item in the line is an authentic reproduction in miniature of regular-size furniture created by master craftsmen during the Colonial period, precision scaled, one inch to one foot.

All wood parts are machined to assure accurate and precise acceptance of each piece by another.

The rooms illustrated have been completed using standard HOUSEWORKS LTD-HOUSE OF MINIATURES products. All individual components are available.

For a complete catalog of the HOUSEWORKS LTD-HOUSE OF MINIATURES furniture line and accessories, write to:

HOUSEWORKS LTD-HOUSE
OF MINIATURES
P.O. Box 0468
147 LAKE STREET
DELAWARE, OH 43015

Please include \$2.00 for Postage
& Handling.

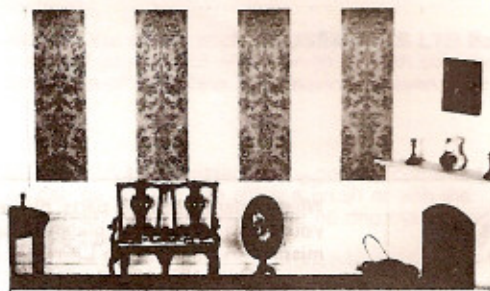
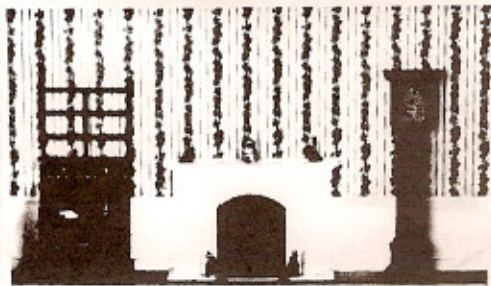

www.TheHouseOfMiniatures.org

INTRODUCTION

INSTRUCTIONS BEFORE STARTING

before starting

Identify and account for each part by placing it on the **LAYOUT SHEET** (Page 2). This will indicate, at a glance, whether any parts are missing. **(See instructions at bottom of last sheet to order missing parts.)**

sanding

NOTE: When using sandpaper, remember that the higher the grit number, the finer the finish.

A. One sanding method that has proved successful is the use of a sanding platform. Tape a sheet of sandpaper of the proper grit size to a hard flat surface such as a table top or wood block. Press down **lightly** and move the piece to be sanded **in the same direction** as the wood grain until the surface is smooth. **Take care not to round any edges or corners of the pieces.**

B. Before assembly, sand all the outer surfaces of individual parts with 220 grit sandpaper, or finer, paying particular attention to edges that will be exposed after assembly. After sanding each piece thoroughly, finish sanding with 400 grit sandpaper. Remember, your final stained finish will only be as smooth as the surface under it.

pre-assembly

A. After sanding, check the proper location and fit of each part by assembling parts loosely, without gluing. Use the **DETAIL VIEWS** (page 3) as a guide.

B. All parts for our kits are made on precision milling machines, using rabbet and dado joints. Parts will fit together snugly with very little adjustments required. When adjustments are required, sand or file to fit.

tools and materials

A. The following tools **will be helpful** in constructing this kit:

1. Knife
2. One-inch Sander
3. Two-inch Sander
4. Large Clamp
5. Small Clamp
6. Swiss Needle File Set
7. Houseworks Ltd Professional Finishing Kit, HOUSEWORKS LTD No. 43801
8. Power Sprayer, HOUSEWORKS LTD No. 43561

B. The following materials **will be needed** to construct this kit:

1. Waxed paper
2. Sandpaper-220, 320 and 400 grit
3. Steel wool-Grade 000
4. Masking tape
5. Wood stain of your choice. **(See Note)**
6. Glaze stain of your choice. **(See Note)**
7. Lacquer or varnish of your choice. **(See Note)**
8. White glue, or any good wood glue. **(See Note)**
9. Sealer **(See Note)**
10. Small artist's brush

NOTE: The HOUSEWORKS LTD No. 43801 Professional Finishing Kit will produce the authentic mahogany finish of the period in which the original furniture was produced. Base stain, glaze stain, lacquer or varnish, sealer and glue are required only if our Professional Kit is not used.

gluing

A. Glue should be applied in small amounts to both surfaces being joined. On end cuts, it may be necessary to apply a second coat of glue before joining the parts.

B. To ensure a tight fit, squeeze excess glue out of the joints by holding glued parts together with either clamps, rubber bands or by placing weights on the parts.

C. Wipe off excess glue promptly with a damp cloth.

D. Be sure a glued assembly has dried thoroughly before adding any more parts.

LAYOUT SHEET

77
(2 REQ'D)

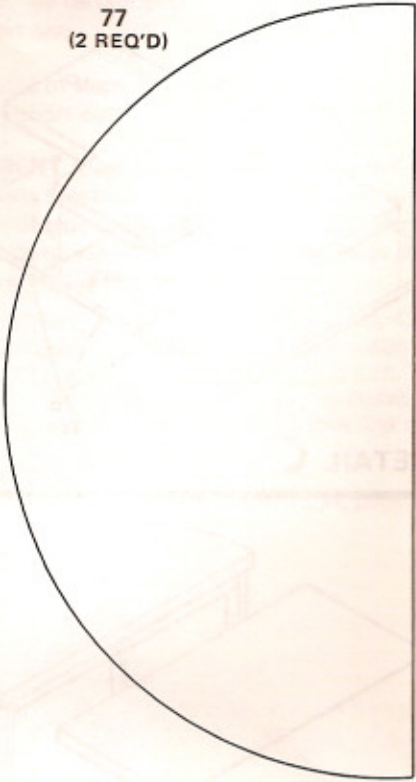

75 BASE

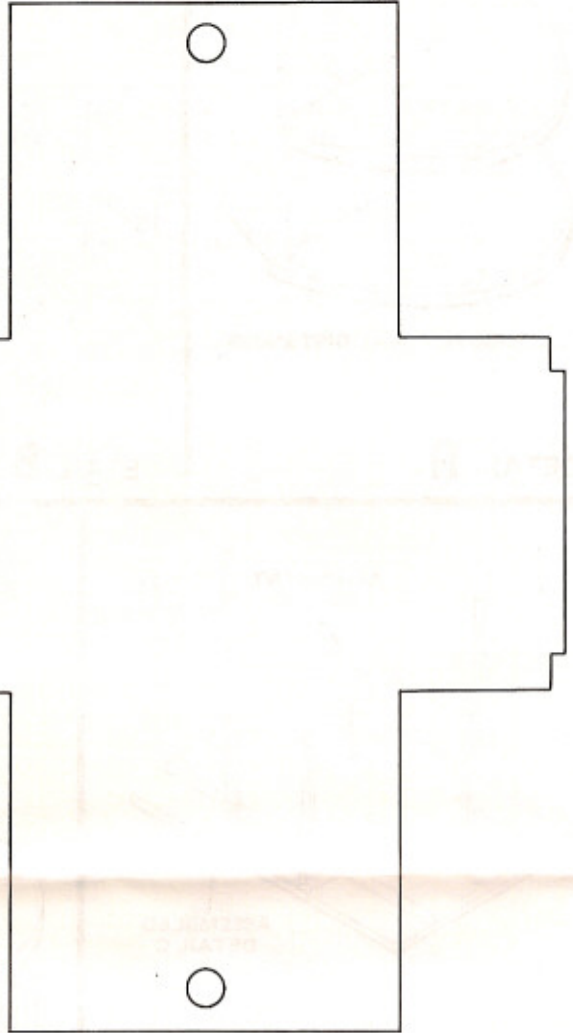

15
(14 REQ'D)



74
(2 REQ'D)

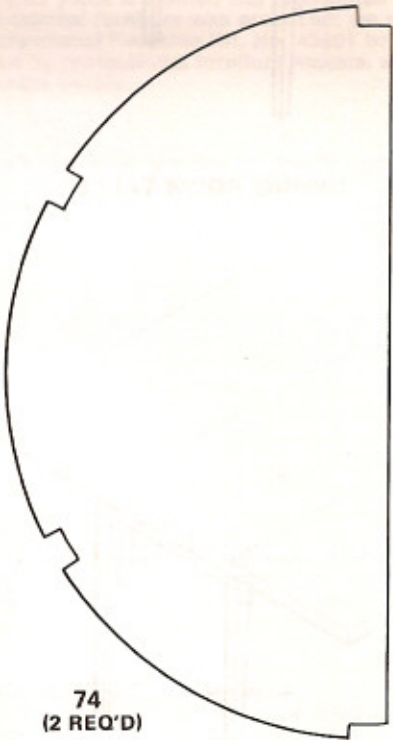

75 TOP
(3 REQ'D)

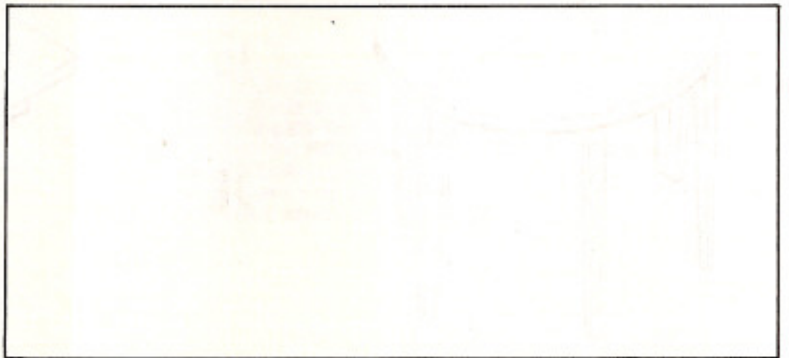

DETAIL VIEWS

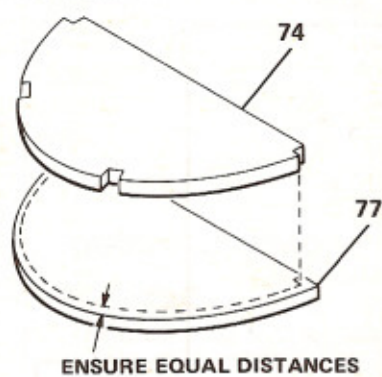

DETAIL A

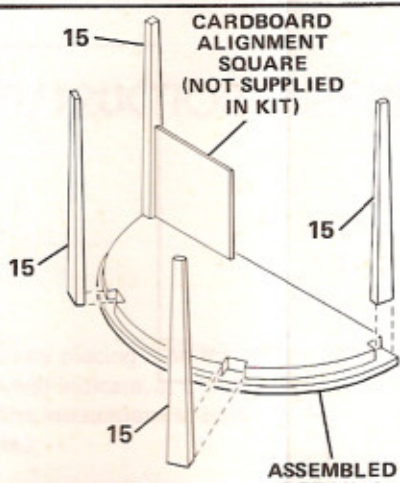

DETAIL B

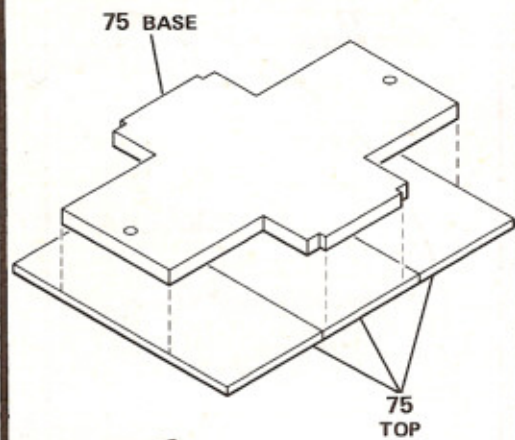

DETAIL C

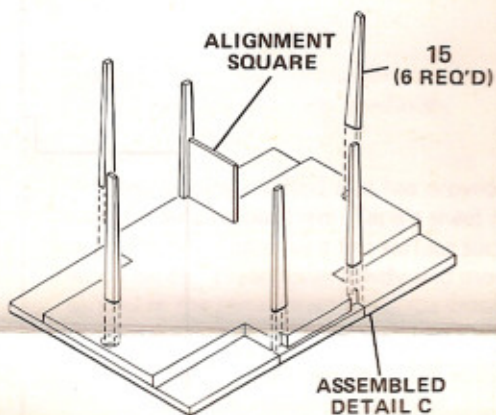

DETAIL D

FINAL ASSEMBLY CAN BE USED IN ANY OF THE STYLES SHOWN

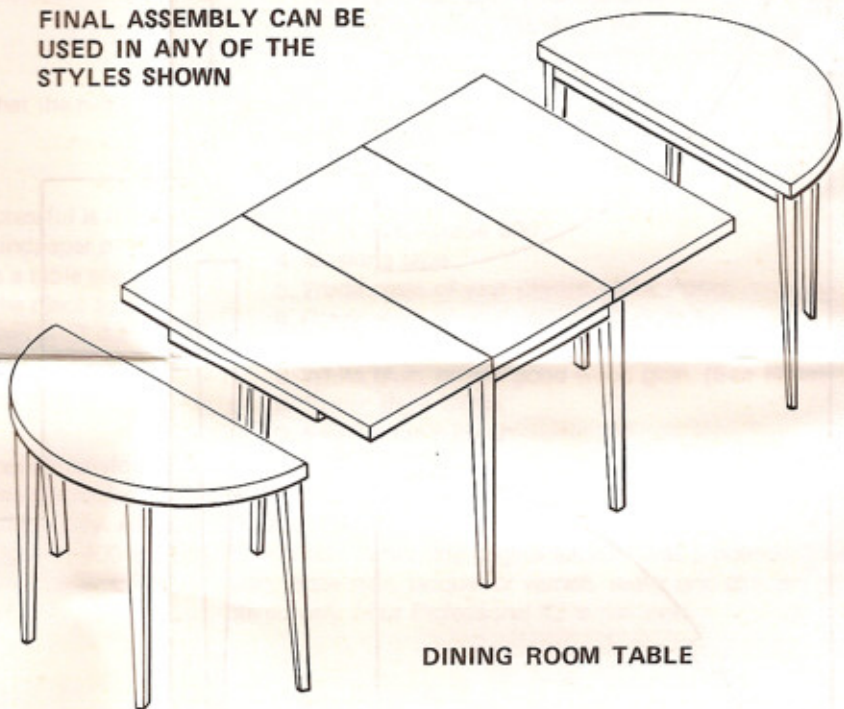

DINING ROOM TABLE

ROUND TABLE

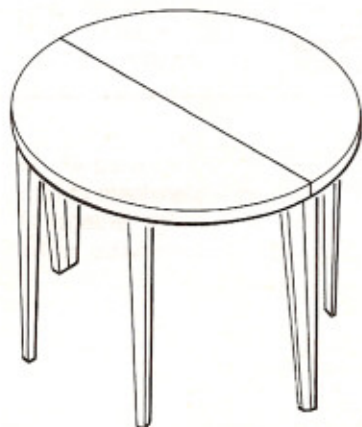

TABLE

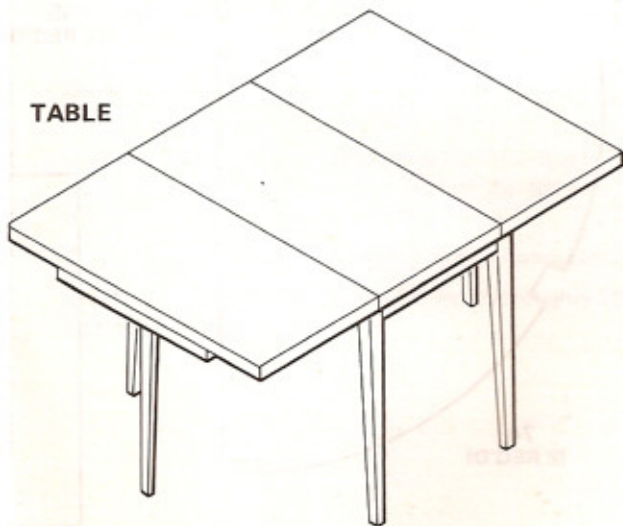

DETAIL E

ASSEMBLY

A. Before starting to assemble your kit, study all illustrations and instructions carefully. Be certain you understand each step before proceeding to the next one.

B. Follow the sequence of steps in the order they are presented. **Do not** skip steps or take any short cuts.

C. Refer to **ALIGNMENT** (page 5) for patterns to be used to align table top ends. When gluing parts together, use a flat toothpick or similar tool to apply a small amount of glue to the parts to be joined. Remove any excess glue promptly with a damp cloth. **Remember to let each glued assembly dry thoroughly before adding the next part.**

D. The Professional Finishing Kit HOUSEWORKS LTD No. 43801, will produce the authentic mahogany finish of this period and contains a **matching tinted glue**, which is recommended for assembly of this kit. The **tinted glue** is of furniture grade quality, equivalent to that used by professional cabinet makers, and its use will avoid the appearance of a glue line at each joint.

E. Begin assembly of the **end section** (see **DETAIL A**, page 3) by gluing part

no. 74 to part no. 77. Align the parts face down (see **ALIGNMENT**, page 5) and clamp the assembly to a table top until glue has set. (Follow instructions for the glue being used for proper setting time.) Repeat the above procedure for the other end section.

F. Complete assembly of the **end section** (see **DETAIL B**, page 3) by gluing the four legs (parts no. 15) to assembled Detail A. It is recommended that a small square be made by hobbyist to align legs. Repeat the above procedure for the opposite table top end.

G. Assemble the **table top** (see **DETAIL C**, page 3) by gluing the table base (part no. 75) to the three sections of the table top (part no. 75). Make sure the base does not overlap the constructed top.

H. Assemble the **main section** (see **DETAIL D**, page 3) by gluing six legs (parts no. 15) to main table top (part no. 75) using the alignment square to ensure legs are straight.

I. You have now completed assembly of your furniture. The assembled pieces should look like that shown in **DETAIL E** (page 3). Now refer to **FINAL FINISHING** to complete the piece.

FINAL FINISHING

In order to ensure that your piece is stained and highlighted in the tones of the period in which the original furniture was produced, we recommend that **HOUSEWORKS LTD Professional Finishing Kit, No. 43801** be used. The following method is used by professional furniture makers, and, if done properly, will result in museum quality.

A. After assembly is completed and the glue has set, **lightly** sand all joint areas to remove excess glue, using 220 grit sandpaper or finer. Moisten a cloth slightly and rub the dampened cloth over the entire wood surface to raise the grain. When all signs of moisture have gone from the wood, resand using a 320 to 400 grit sandpaper.

B. With a small brush, apply a light sealer coat to all edges and end grains. Use the side of the brush rather than the tip, in a wiping motion, so that the sealer does not touch other surfaces. Sealing the edge and end grains will prevent the subsequent stains from penetrating these areas as deeply, resulting in a more uniform stain on all parts.

NOTE: If our Finishing Kit (which contains a high quality sealer) is not used, thinned varnish or lacquer can be used for this purpose.

C. To match the color of furniture of this period apply **HOUSEWORKS LTD Base Stain** or mahogany or cherry stain of your choice with a brush or cloth over the entire wood surface. Immediately wipe off all excess stain leaving an even color on the surface. Allow to dry.

D. Apply a thin coat of **HOUSEWORKS LTD Sealer** or any commercial wood sealer over the base stain. This can be applied with either a brush or with the **HOUSEWORKS LTD Power Sprayer**. Make sure there are no drip marks present. Allow the sealer to dry for at least 6 hours.

HOUSEWORKS LTD POWER SPRAYER No. 43561 can be used to apply sealer, top coat, and paints for outstanding results. This spray ensures application of an even coat, especially on intricate and flat surfaces, and it is highly recommended for finishing your furniture.

E. Lightly go over all surfaces with Grade 000 steel wool until they are smooth to the touch.

F. **"Highlighting"** is a technique of creating light and dark areas and is accomplished by applying the **HOUSEWORKS LTD Glaze Stain** or any commercial glaze stain of your choice (Van Dyck Brown is the color recommended) and then toning by rubbing off the glaze in certain areas, exposing the base stain. In order to "highlight", apply a dark glaze with a brush or rag over the entire piece of furniture. As soon as you have applied this glaze, wipe off the excess. Blend tones of base color and glaze stain by using a piece of soft cloth. There should never be a sharp line of dark color to light color, but rather a smooth blending effect. Lighten the middle surface of the wood, but do not lighten the entire surface. The **"highlighting"** technique will produce museum quality miniature furniture.

G. After the glaze stain has dried for 24 hours, thoroughly and briskly wipe all surfaces with a clean cloth until you are satisfied with the appearance. Apply the **HOUSEWORKS LTD Top Coat** or a coat of lacquer or varnish, with a brush, an airbrush, or with the **HOUSEWORKS LTD Power Sprayer**. Apply two or more top coats with light buffing between coats using Grade 000 steel wool. After each steel wool rubbing make sure all steel wool "dust" is removed thoroughly. **(Continue with ASSEMBLY starting with paragraph K).**

ALIGNMENT

A. Tape this sheet to a smooth, flat surface. Then tape sheet of waxed paper to the pattern so that any excess glue at the joint will not stick to the pattern, making it difficult to remove the completed assembly.

B. Use the alignment pattern shown here to position the indicated parts properly and to hold them in alignment while drying.

alignment pattern

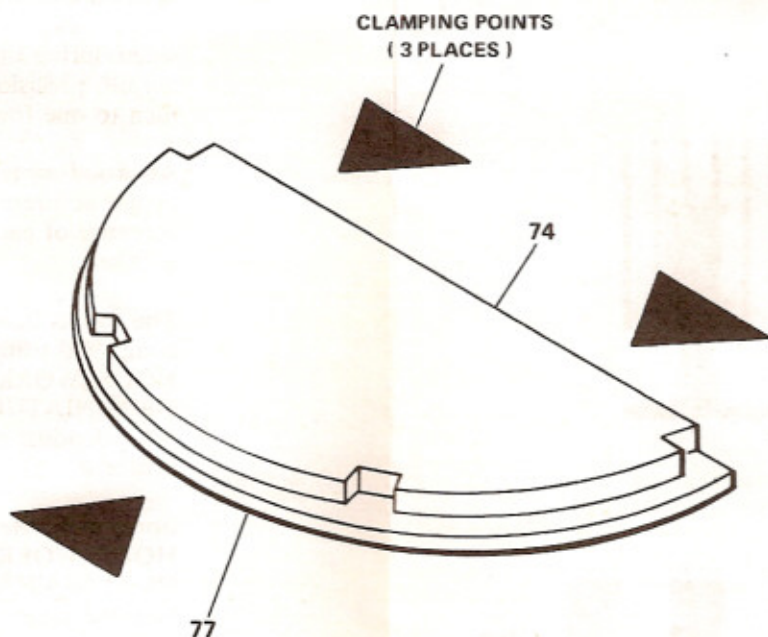
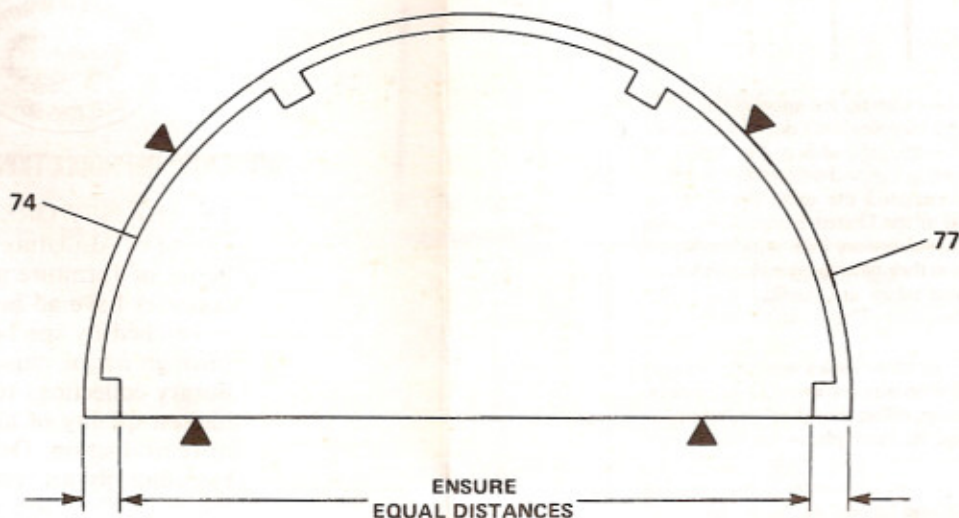

Every effort has been made to insure the completeness of this KIT—however, should any parts be missing, write directly to:
HOUSEWORKS LTD-HOUSE OF MINIATURES
P.O. Box 0468
147 Lake Street
Delaware, OH 43015



When ordering missing parts, please Print your name and address plainly. State the missing PART NO. (See LAYOUT SHEET, page 2), KIT NO. 40006 and the Kit Name, "HEPPLWHITE THREE PIECE DINING ROOM TABLE".