

## COLLECTORS NO. 40040



Chippendale  
Open Arm Chair

*Circa 1750*

The Open Arm Chair is also often called a "Ladies Chair." Its name is quite obviously derived from the open construction of its arms as opposed to a fully upholstered piece. It should not be confused with the Hepplewhite design that is commonly called the "Martha Washington Chair."

The fabric was usually fairly plain although damask and even needlepoint coverings weren't uncommon.

The exposed wood was mahogany and was often relieved with ornate carvings, especially the cabriole legs.

Many versions of this chair were made with both cabriole legs and straight legs. A few versions may be found with cabriole legs joined with turned stretchers but they are extremely rare.

This chair may be used as an occasional chair in almost any room in the house.

## ASSEMBLY AND FINISHING INSTRUCTIONS



AUTHENTIC REPRODUCTIONS IN MINIATURE

The X-ACTO® House of Miniatures Collectors Series® of furniture and accessories have all been carefully researched by specialists through major museum and library collections to assure the highest quality of authenticity in reproduction. Details are extraordinarily accurate to satisfy the most discriminating miniaturist.

All wood parts are machined to assure accurate and precise acceptance of each piece by another.

For a complete catalog of the X-ACTO® HOUSE OF MINIATURES furniture line and accessories, write to:

X-ACTO® THE HOUSE OF MINIATURES Dept. KIT  
45-35 Van Dam Street  
Long Island City,  
New York 11101

*Please include \$2.00 for postage and handling.*

## INTRODUCTION

## BEFORE STARTING

Identify and account for each part by placing it on the Layout Sheet (make sure the correct layout sheet is used when working on multi-kit Instruction Sheets). Should any parts be missing, send a post card to:

X-ACTO/The House of Miniatures  
45-35 Van Dam Street  
Long Island City, N.Y. 11101

Please print Name, Address, Part Number (Number from Layout Sheet) and Kit Name and Number on card when ordering.

## SANDING

Before assembly, sand all the outer surfaces of individual parts with 220 grit sandpaper, or finer, sanded in the same direction as the wood grain until the surface is smooth. Take care not to round any edges or corners of the pieces. Finish sanding with 280 grit sandpaper.

## PRE-ASSEMBLY

A. After sanding, check the proper location and fit of each part by assembling parts loosely, without gluing. Use the DETAIL VIEWS as a guide.

B. All parts for X-ACTO kits are made on precision milling machines. When adjustments are required, sand to fit.

## TOOLS AND MATERIALS

A. The following tools will be helpful in constructing this kit:

1. Two-inch Sander, X-ACTO No. 7042
2. Small Clamp, X-ACTO No. 7003
3. X-ACTO Professional Finishing Kit (or equivalent, see note)

B. The following materials will be needed to construct this kit:

1. X-ACTO Tinted Glue (see note)
2. Sandpaper - 220 and 280 grit
3. White glue (or equivalent)
4. Small Artist's Brush

NOTE: The X-ACTO tinted glue is matched to the finish used in the Professional Finishing Kit. This will produce the authentic finish of the period in which the original Furniture was produced. When not using X-ACTO glue follow manufacturer's directions.

## GLUING

A. Glue should be applied in small amounts to surface being joined. When gluing dado joints apply glue to dado only.

B. To ensure a tight fit, squeeze excess glue out of the joints. Hold glued parts together with clamps, rubber bands or weights on the parts.

C. Wipe off excess glue promptly.

D. Be sure a glued assembly has dried thoroughly before adding parts.

## FINISHING

The X-ACTO Professional Finishing Kit enables you to finish your furniture by the same process used by the professional furniture maker. The end result is what is important — there are easier methods, but none that will give the quality results that this process will. If you use a finish other than X-ACTO's, refer to the manufacturer's directions.

# Detail Views

KIT 40040

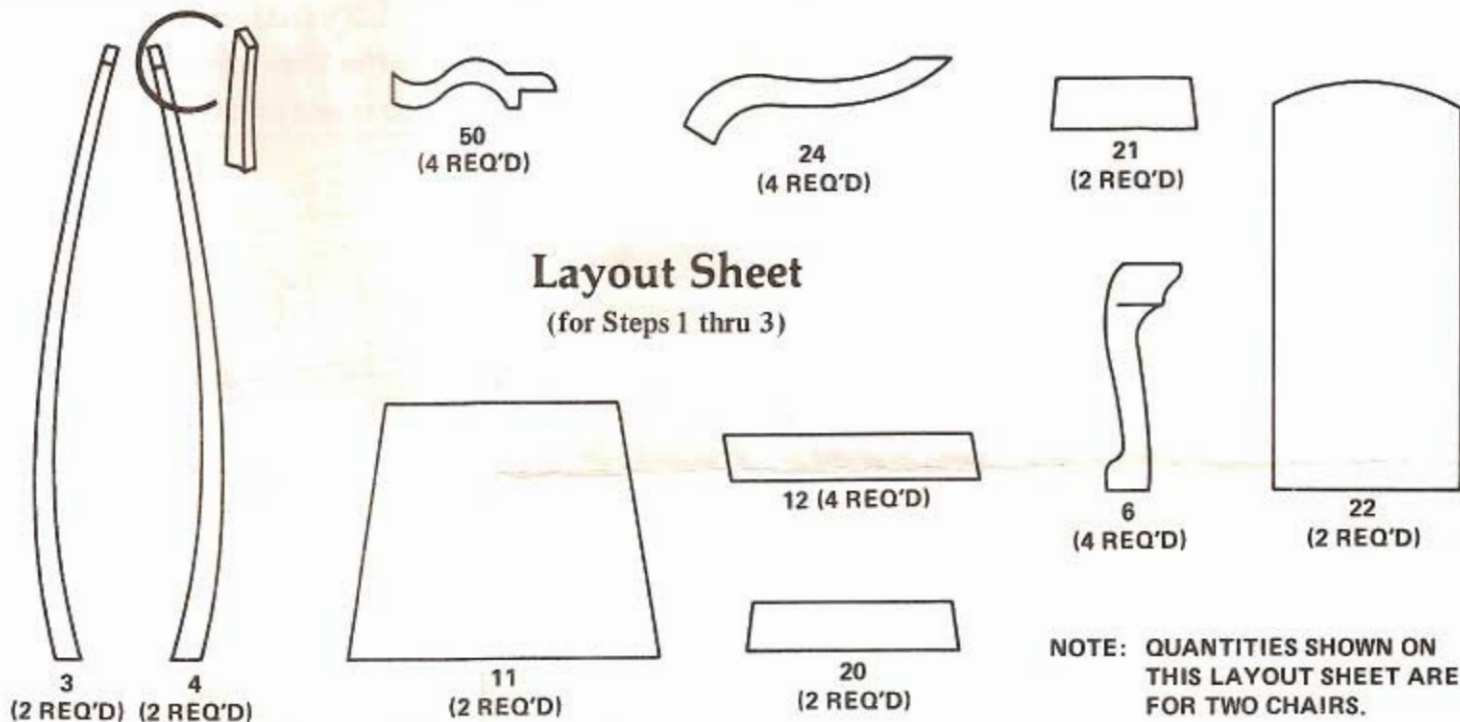

## Step 1

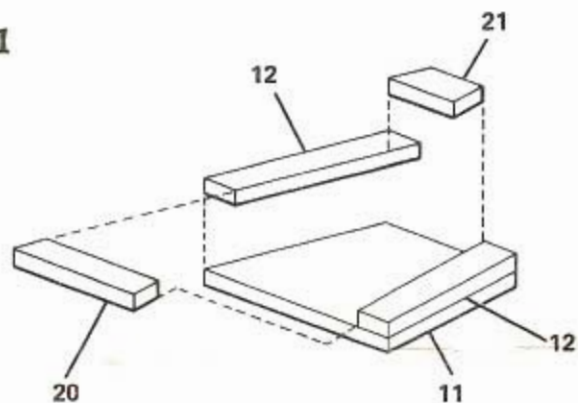

- A. Glue braces (12) to bottom (11).  
B. Glue brace (20) and (21) to bottom (11). Ensure all edges are flush.

## Step 2

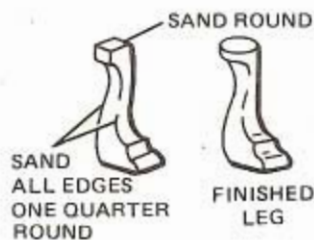

**NOTE:** Cabriole legs (6) may be shaped prior to assembly.

- A. Shape legs by sanding.  
B. Sand base of leg until it is round.

SAND ALL EDGES ONE QUARTER ROUND



C. Shape arms and arm supports by sanding.

## Step 3

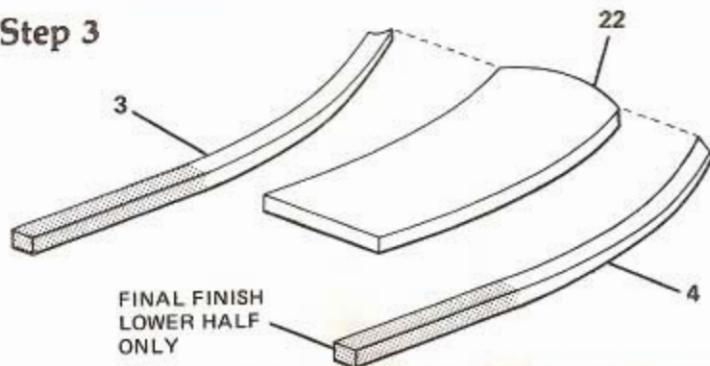

- A. Glue right leg (4) and left leg (3) to back (22).  
B. Refer to Final Finishing for arms (24), arm supports (50), Legs (6) and lower half of (3) and (4).

# Detail Views

KIT 40040

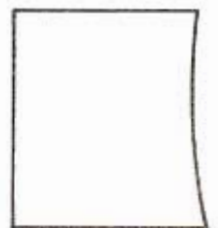

18 (CARDBOARD)

10 (FOAM)  
(2 REQ'D)

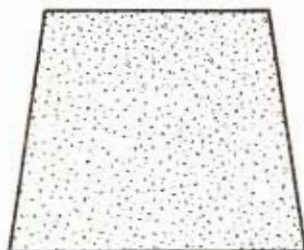

25 (CARDBOARD)  
(2 REQ'D)

23 (FOAM)  
(2 REQ'D)



## Layout Sheet

(for Steps 4 thru 12)

27 (3 REQ'D) MATERIAL

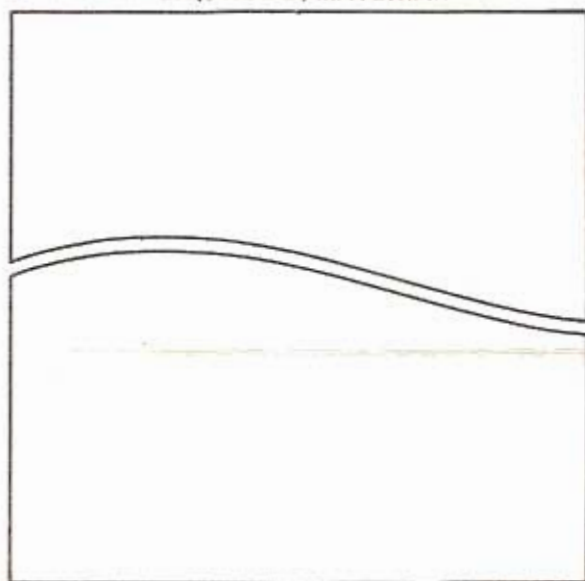

### Step 4

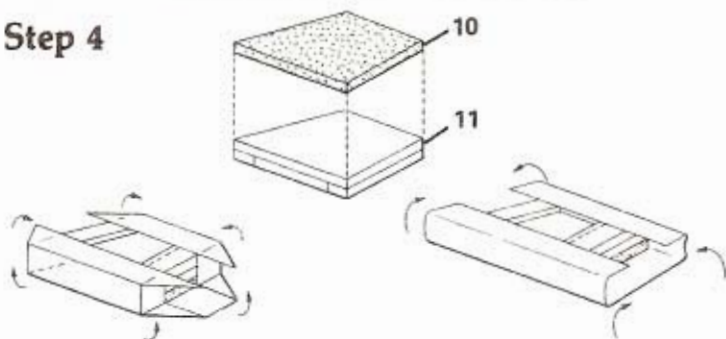

**NOTE:** Cut each piece of fabric into 3 inch squares.

A. Glue cushion (10) to base (11) with white glue.

B. Place cushion (10) down on fabric (27).

C. Fold front and rear of fabric (93) over and glue in place.

D. Tuck each corner under.

E. Fold sides of fabric and glue in place with white glue.

**NOTE:** Trim excess fabric.

### Step 5

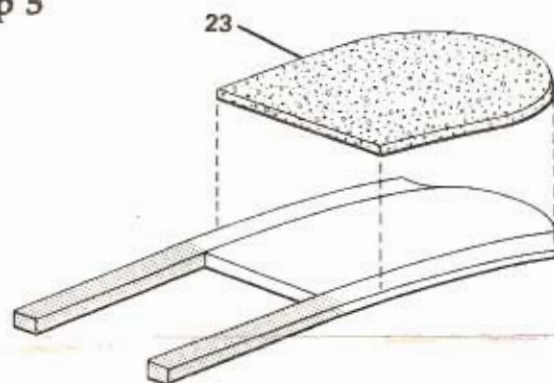

A. Glue cushion (23) to back assembly. Keep top edge of cushion flush with top edge of back assembly.

### Step 6

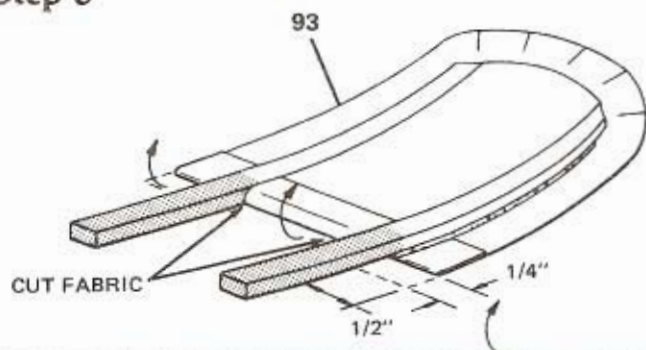

A. Position back assembly with cushion down on fabric, allowing 1/4 inch overhang at bottom. Trim to 1/2 inch.

B. Cut fabric along inside edge of each leg.

C. Fold inside flap around lower back and glue in place.

D. Fold outside flaps even with bottom of back (22).

E. Clip fabric at top.

# Detail Views

## KIT 40040

### Step 7

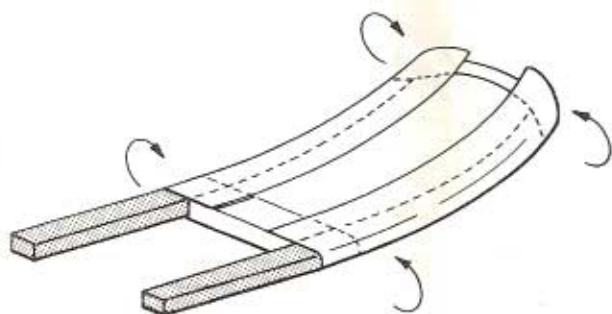

A. Fold sides of fabric around and glue in place. Ensure fabric is flush with bottom edge of back.

### Step 8

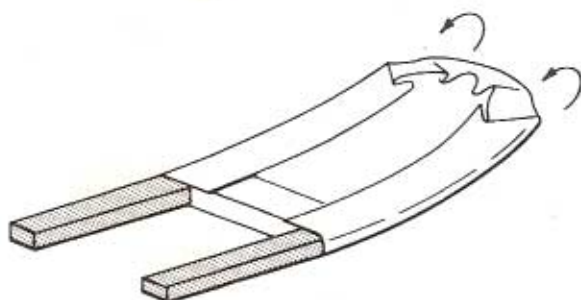

A. Starting from outside edge, tuck and fold material over back and glue in place.

### Step 9

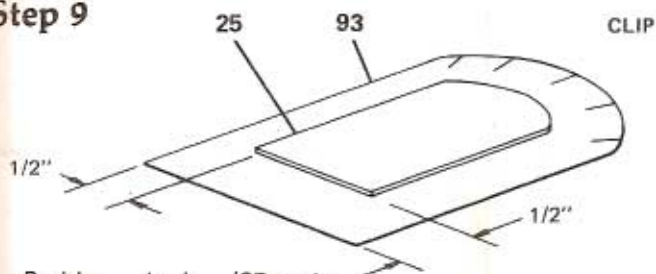

A. Position back (25-cardboard) on fabric, trim to 1/2 inch of back.

B. Clip fabric at top.

C. Fold top and bottom and glue in place.

D. Fold sides over and glue in place.

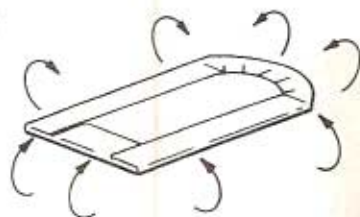

### Step 10

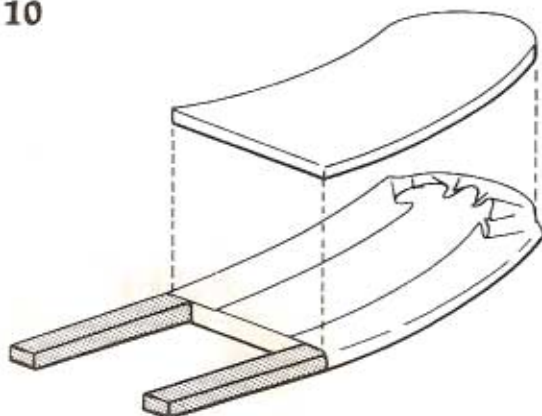

NOTE: Shave excess fabric A. Glue back to chair back from back assembly to ensure a close fit.

### Step 11

ALIGNMENT GUIDE 18

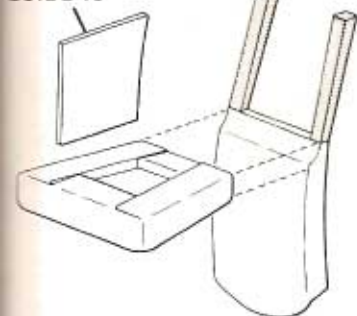

A. Glue seat assembly to back assembly with white glue. Ensure sufficient amount of glue is used to penetrate fabric.

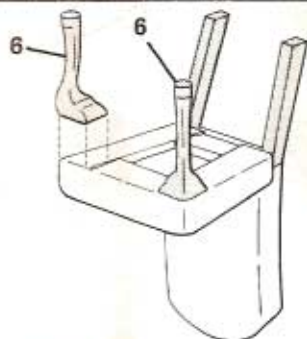

NOTE: The alignment guide should be used to align seat assembly. Hold in position until glue has set.

B. Glue front legs (6) to bottom of seat assembly, aligning front edges of legs with seat.

### Step 12

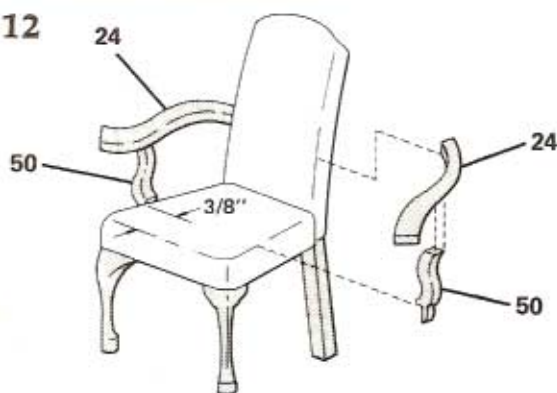

A. Glue arm supports (50) to seat assembly 3/8 inch from front edge using white glue.

B. Glue arms (24) to back and arm supports (50).

NOTE: Ensure arms and supports are properly aligned, hold in place until glue sets.