



Queen Anne Fire Screen Circa 1725-1760 *Circa 1725-1760*

Queen Anne, second daughter of James II, ruled England from 1702 until 1714. The furniture style that bears her name, however, covers a period of forty years. The Queen Anne style, developed during this age of flourishing craftsmanship, brought to American furniture greater lightness and grace and a new concept of comfort.

In America, the furniture was made in a Queen Anne style from about 1725-1750. The American versions were smaller scale than older styles, but more substantial than their English counterparts. Veneer was less used here. The fashionable wood was walnut, followed by the native hardwoods, maple and cherry, and then mahogany, which became most important about 1720.

The fire screen, also known as "pole screen," was used as a protection from the heat of a fire. Since the fireplace was the only source of heat in the homes of this period, it was common to find the lady of the home sitting near the fire to warm herself - with the firescreen protecting her face from the fire itself.

They were called "pole screens" since it had a pole to support the screen itself. The screen was attached to the pole in such a manner that it could be raised or lowered to any height desired. The legs are of the tripod design with the cabriole shape, and has a turned vase column to which the pole is attached. The ornamentation within the frame itself consists chiefly of needle work and paintings of flowers, sometimes covered with protective glass. Found commonly in drawing rooms, parlors or sitting rooms near the fireplace.

INTRODUCTION

BEFORE STARTING

Identify and account for each part by placing it on the Layout Sheet (make sure the correct layout sheet is used when working on multi-kit Instruction Sheets). Should any parts be missing, send a post card to:

THE HOUSE OF MINIATURES
Customer Service - Parts Dept.
2000 Craftmark Center
Statesville, NC 28677-2000

Please print Name, Address, Part Number (Number from Layout Sheet) and Kit Name and Number on card when ordering.

SANDING

Before assembly, sand all the outer surfaces of individual parts with 220 grit sandpaper, or finer, sanded in the same direction as the wood grain until the surface is smooth. Take care not to round any edges or corners of the pieces. Finish sanding with 280 grit sandpaper.

PRE-ASSEMBLY

- After sanding, check the proper location and fit of each part by assembling parts loosely, without gluing. Use the **DETAIL VIEWS** as a guide.
- All parts for X-ACTO kits are made on precision milling machines. When adjustments are required, sand to fit.



AUTHENTIC REPRODUCTIONS IN MINIATURE

The X-ACTO® House of Miniatures Collectors Series® of furniture and accessories have all been carefully researched by specialists through major museum and library collections to assure the highest quality of authenticity in reproduction. Details are extraordinarily accurate to satisfy the most discriminating miniaturist.

All wood parts are machined to assure accurate and precise acceptance of each piece by another.

For a complete catalog of the X-ACTO® HOUSE OF MINIATURES furniture line and accessories, write to:

THE HOUSE OF MINIATURES
Customer Service - Catalog Dept.
80 Newbridge Road
Bergenfield, NJ 07621

TOOLS AND MATERIALS

A. The following tools will be helpful in constructing this kit:

- Two-inch Sander, X-ACTO No. 7042
- Small Clamp, X-ACTO No. 7003
- X-ACTO Professional Finishing Kit (or equivalent, see note)

B. The following materials will be needed to construct this kit:

- X-ACTO Tinted Glue (see note)
- Sandpaper - 220 and 280 grit
- Steel Wool - Grade 0000
- Small Artist's Brush

NOTE: The X-ACTO tinted glue is matched to the finish used in the Professional Finishing Kit. This will produce the authentic finish of the period in which the original Furniture was produced. When not using X-ACTO glue follow manufacturer's directions.

GLUING

- Glue should be applied in small amounts to surface being joined. When gluing dado joints apply glue to dado only.
- To ensure a tight fit, squeeze excess glue out of the joints. Hold glued parts together with clamps, rubber bands or weights on the parts.
- Wipe off excess glue promptly.
- Be sure a glued assembly has dried thoroughly before adding parts.

FINISHING

The X-ACTO Professional Finishing Kit enables you to finish your furniture by the same process used by the professional furniture maker. The end result is what is important - there are easier methods, but none that will give the quality results that this process will. If you use a finish other than X-ACTO's, refer to the manufacturer's directions.

Layout Sheet

Detail Views

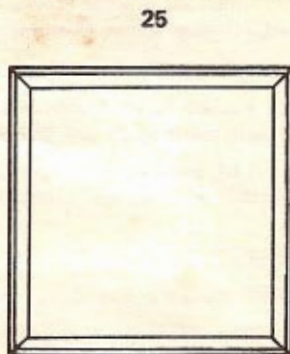
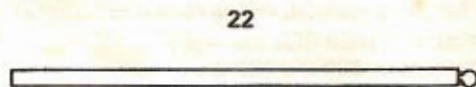
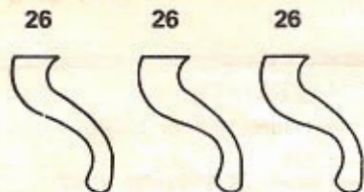
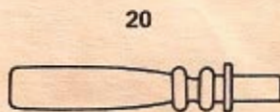

Step 1

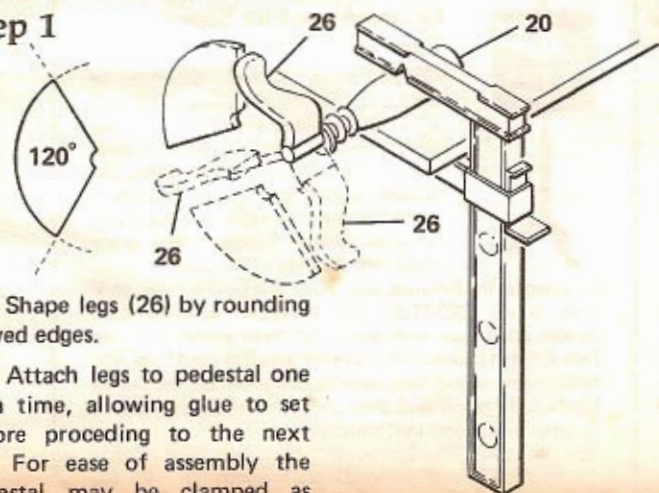

A. Shape legs (26) by rounding curved edges.

B. Attach legs to pedestal one at a time, allowing glue to set before proceeding to the next leg. For ease of assembly the pedestal may be clamped as shown. Cut out the 120° guide for correct spacing of legs.

Step 2

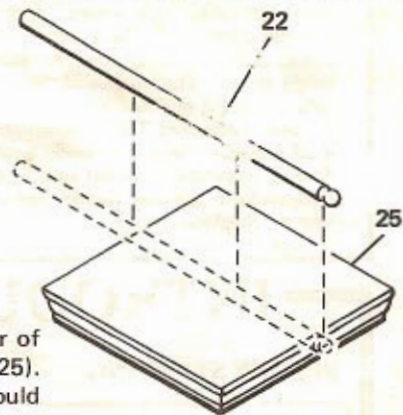

A. Glue post (22) to center of contoured edge of screen (25). Contoured edge of screen should face forward. Turned end of post should project slightly above screen. If you desire post may be glued diagonally across screen.

Step 3

A. Place a small amount of glue on the end of the post and insert it into the hole in the pedestal.

B. After all glue has set firmly check that the fire screen stands correctly. Slight adjustments may be made by sanding base of the legs.

C. Apply finish.

