

ASSEMBLY AND FINISHING INSTRUCTIONS

Williamsburg™

CHIPPENDALE BOOKCASE (No. 51113)

Colonial Williamsburg is truly one of America's great national treasures . . . a magical link with our nation's proud heritage. Displayed throughout its meticulously restored homes and public rooms are antique furnishings and accessories that have delighted visitors from all over the world.

Of the many handsome furnishings to be found in the Peyton Randolph Office in Williamsburg, this tall and majestic bookcase is among the most impressive. Of English origin, circa 1740, it represents Chippendale furniture styling at its very finest.

In colonial times books were a luxury and a symbol of the owner's education and community status. As a result, they were prominently displayed for all to see. The large drawer in the base was probably used to store unbound publications and maps. Bookcases were also used to display other fine possessions such as silver, vases and statuary.



AUTHENTIC REPRODUCTIONS IN MINIATURE

THE HOUSE OF MINIATURES is honored to have been appointed the exclusive manufacturer of authentic miniatures of WILLIAMSBURG antiques. Each antique is an approved 1/2 scale recreation and reflects the same high quality standards for which THE HOUSE OF MINIATURES has become known over the years.

Each WILLIAMSBURG miniature has been carefully researched to assure the highest degree of authenticity. Details are extraordinarily accurate to satisfy the most discriminating miniaturist. All wood parts are machined to assure accurate and precise assembly.

For information on the complete line of WILLIAMSBURG miniatures, write to:

THE HOUSE OF MINIATURES
Customer Service—Catalog Dept.
80 Newbridge Road
Bergenfield, NJ 07621

INTRODUCTION

BEFORE STARTING

Identify and account for each part by placing it on the Layout Sheet. Should any parts be missing, send a post card to:

THE HOUSE OF MINIATURES
Customer Service - Parts Dept.
2000 Craftmark Center
Statesville, N.C. 28677-2000

Please print Name, Address, Part Number (Number from Layout Sheet) and Kit Name and Number on card when ordering.

B. The following materials will be needed to construct this kit:

1. X-ACTO Tinted Glue (see note)
2. Sandpaper - 220 and 280 grit
3. White glue (or equivalent)
4. Small Artist's Brush

NOTE: The X-ACTO tinted glue is matched to the finish used in the X-ACTO Finishing Kit. This will produce the authentic finish of the period in which the original furniture was produced. When not using X-ACTO glue follow manufacturer's directions.

SANDING

Before assembly, sand all the outer surfaces of individual parts with 220 grit sandpaper, or finer, sanded in the same direction as the wood grain until the surface is smooth. Take care not to round any edges or corners of the pieces. Finish sanding with 280 grit sandpaper.

PRE-ASSEMBLY

- A.** After sanding, check the proper location and fit of each part by assembling parts loosely, without gluing. Use the **DETAIL VIEWS** as a guide.
- B.** All parts for X-ACTO kits are made on precision milling machines. When adjustments are required, sand to fit.

GLUING

- A.** Glue should be applied in small amounts to surface being joined. When gluing dado joints apply glue to dado only.
- B.** To ensure a tight fit, squeeze excess glue out of the joints. Hold glued parts together with clamps, rubber bands or weights on the parts.
- C.** Wipe off excess glue promptly.
- D.** Be sure a glued assembly has dried thoroughly before adding parts.

TOOLS AND MATERIALS

A. The following tools will be helpful in constructing this kit:

1. Two-inch Sander, X-ACTO No. 7042
2. Large Clamp, X-ACTO No. 7004
3. Small Clamp, X-ACTO No. 7003
4. X-ACTO Finishing Kit—Walnut (or equivalent, see note)
5. Pin Vise Set, X-ACTO No. 7144

FINISHING

The X-ACTO Finishing Kit enables you to finish your furniture by the same process used by the professional furniture maker. The end result is what is important—there are easier methods, but none that will give the quality results that this process will. If you use a finish other than X-ACTO, refer to the manufacturer's directions.

LAYOUT SHEET

KIT 51113

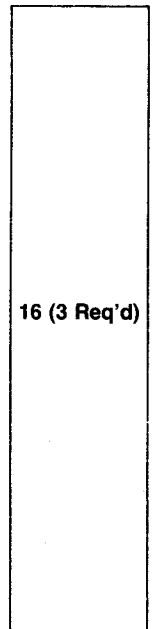
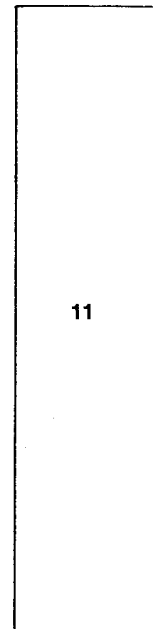
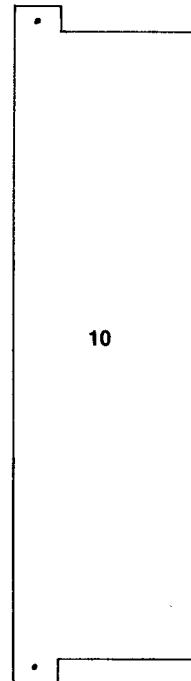
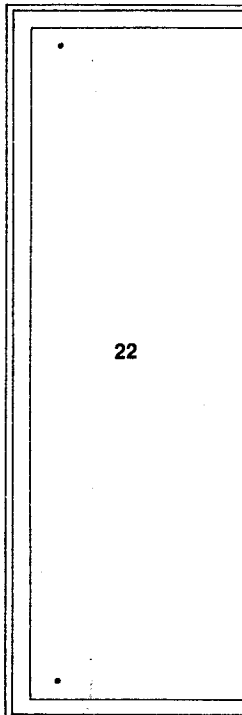
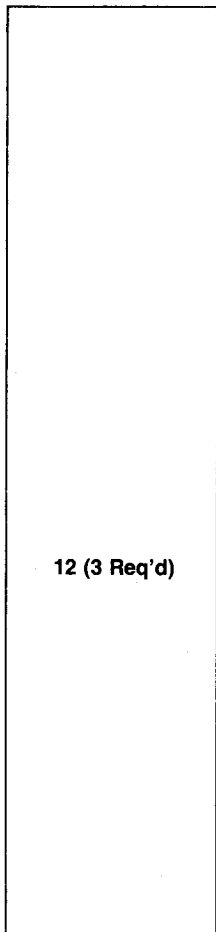
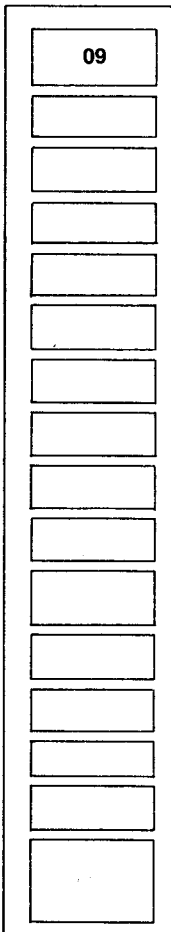
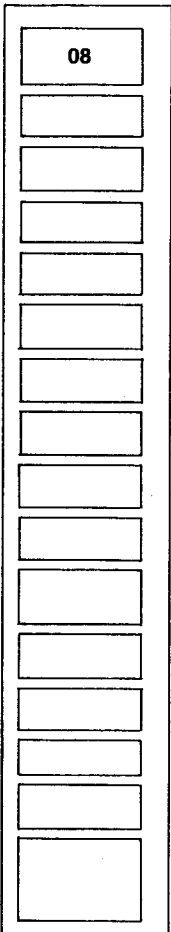
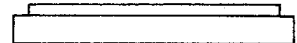
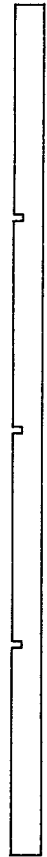
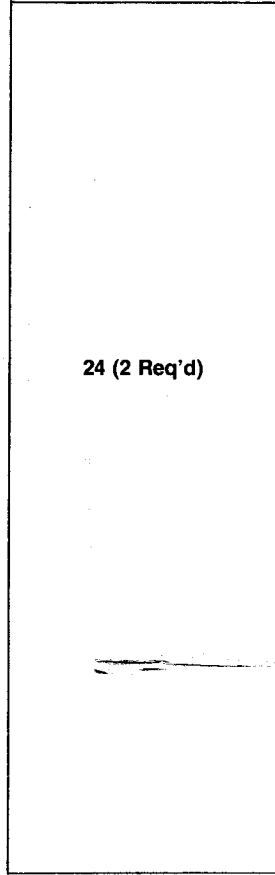
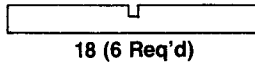
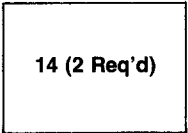
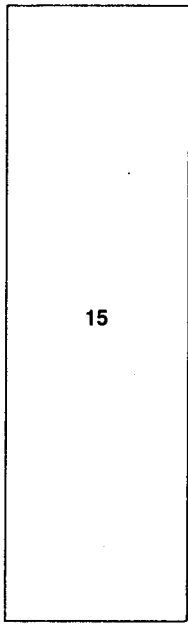
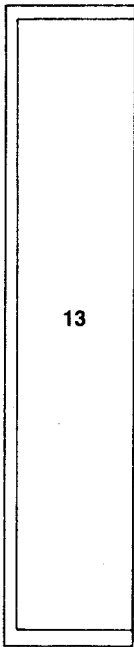
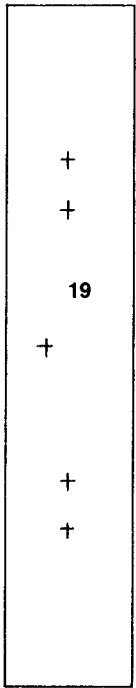

LAYOUT SHEET

KIT 51113

DETAIL VIEWS

KIT 51113

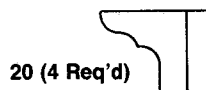
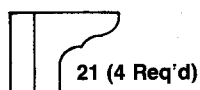
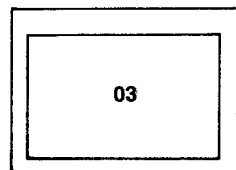
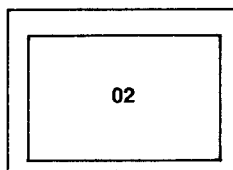
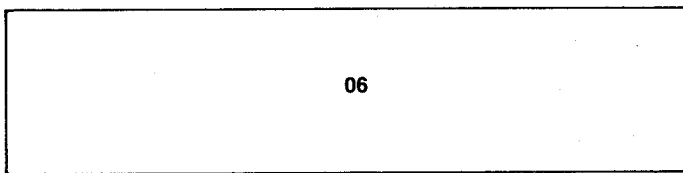
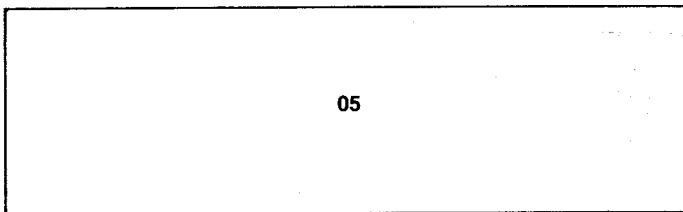
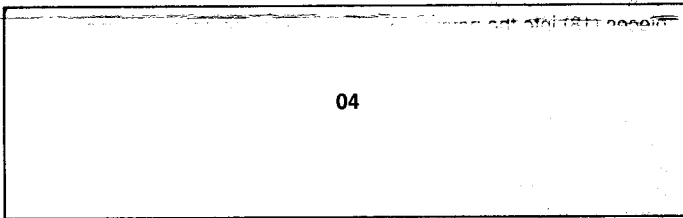
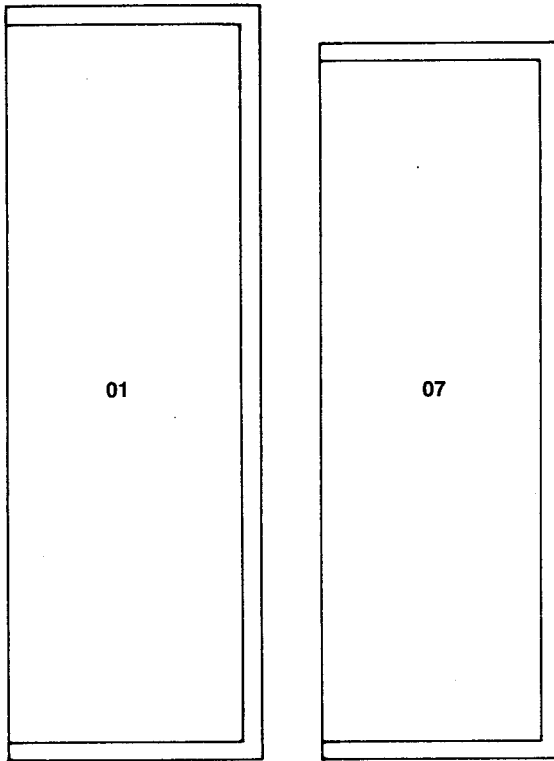

STEP 1:

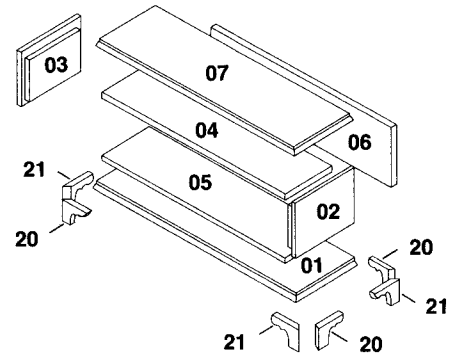

- Assemble the drawer case by gluing the horizontal frame pieces (04 & 05) into the rabbets of the ends (02 & 03) so that they are flush at the front. (**NOTE:** Part (05) is the thinner of the two frame pieces. The fronts of the ends (02 & 03) have the narrow, 1/16", rabbet.) Glue the back (06) in place and square the assembly.
- Glue on the base (01) so that it is centered and is flush at the rear. Glue on the cap (07) so that it is centered and flush at the front. Sand the rear of the assembly so that it is smooth and flush.
- Glue together parts (20 & 21) to form four bracket feet and then glue them to the base (01) so that they are flush with the edges at the corners.

STEP 2:

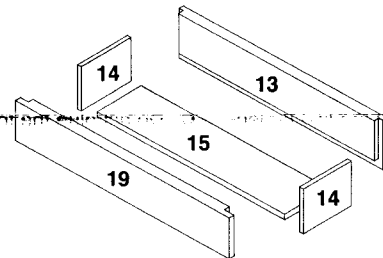

- Note:** Use white glue for Step 2.
- Assemble the drawer by gluing the bottom (15) into the bottom rabbet of the drawer back (13) and then glue the sides (14) to the ends of the bottom and into the side rabbets of the back. Once the glue has set, check the fit of the drawer body in the case assembly. Sand as needed.
 - Check the fit of the drawer front (19) in the case opening. Glue the drawer front to the drawer body. Allow the glue to set and check the fit again. Sand if needed so that the drawer slides in and out easily.
 - Using the spacing shown on Layout Sheet, position the escutcheons (57) for the handles and drill the holes for the posts (59). These holes should be slightly smaller than the diameter of the posts.
 - The drawer and base assembly are ready for finishing at this point. The base assembly is not glued to the bookcase until the final assembly. (See Step 5.)

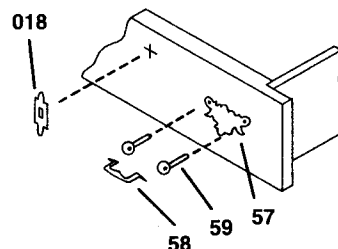

HARDWARE CHECKLIST	
Hinge Pin	4
Escutcheon Plate	2
Handle Bail	2
Handle Post	4
Keyhole Plate	3

DETAIL VIEWS

KIT 51113

STEP 3:

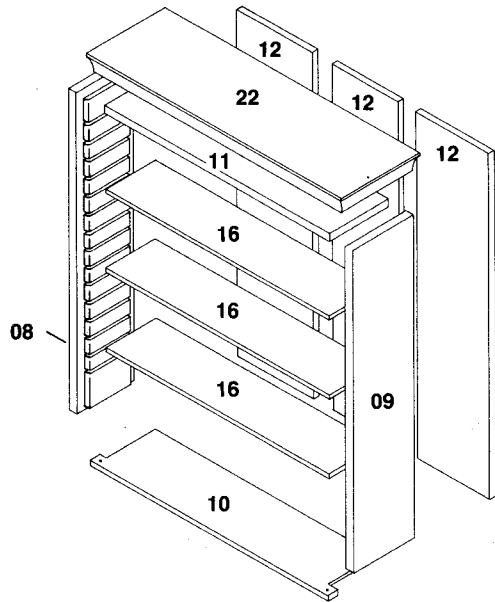

- A.** Assemble the bookcase by gluing the horizontal frame pieces (10 & 11) into the rabbets of the sides (08 & 09). Frame piece (11) should be flush with the front of the sides and frame piece (10) extends forward of the sides so that the two projections at each end fit against the front edges of the sides. **(NOTE:** The bottom of the sides has the narrow, $\frac{1}{16}$ " rabet and the curved edge of the dadoed shelf supports faces forward.) Square the assembly.
- B.** Glue the three back pieces (12) together. When the glue has set, sand them smooth. Check the fit into the rear of the assembly made in "A." Sand if needed and then glue into place.
- C.** Do not glue the top (22) in place as yet. (See Step 4.)
- D.** Sand and check the fit of the three adjustable shelves (16) in the dadoes of the case. They should fit loosely since there will be some build-up on them and in the dadoes during the finishing.

STEP 4:

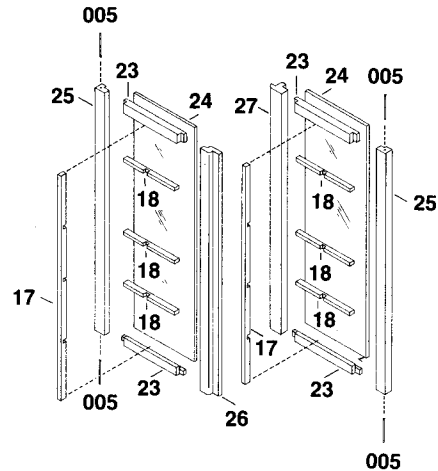

- A.** Assemble the left door by gluing the horizontal frame pieces (23) into the rabbets of the vertical frame pieces (25 & 26). Square the frame and allow the glue to set.
- B.** Assemble the right door by gluing the horizontal frame pieces (23) into the rabbets of the vertical frame pieces (25 & 27). Square the frame and allow the glue to set.
- C.** Glue the horizontal mullion pieces (18) into the notches of the vertical mullions (17). Do not force the pieces together, sand if needed for a proper fit. Make two sets. When the glue has set, check the fit of these assemblies into the door frames. Do not force them in, sand the ends of the mullions as needed. Glue them in place so that they are clear of the rabet around the inside of the frame which holds the door pane.
- D.** Apply the finish to the doors before gluing the door panes in place.
- E.** Lay the bookcase on its back and hold, or clamp, the top (22) in place. Follow the procedure outlined in Step 5 for installing the doors, but do not insert the lower pin completely. Check the fit of the doors and the alignment of the top. Remove the doors and glue the top in place.
- F.** Complete the staining and finishing of all the various pieces and assemblies. **(NOTE:** Walnut is considered the most authentic finish.)

STEP 5:

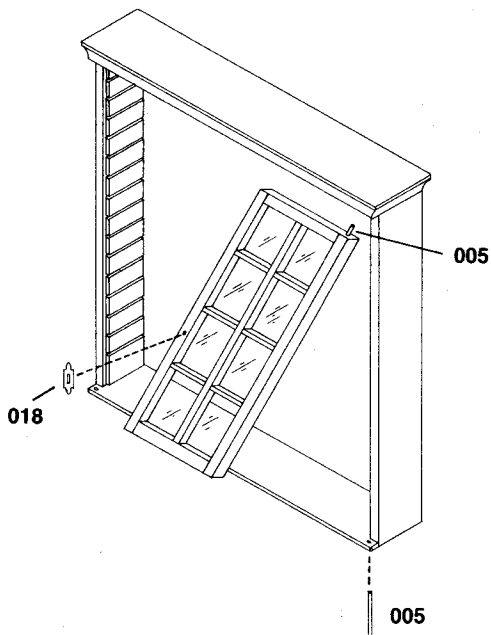

- A.** When the finishing is complete glue the panes (24) into the rabbets of the doors with white glue.
- B.** Insert the hinge pin (005) into the top of the outer door frame. It should protrude approximately $\frac{1}{8}$ ". Trim if needed. Swing the door in place and insert another hinge pin through the hole in the bottom and into the hole in the bottom of the door frame. Push the pin in and trim off any excess. Install the other door in the same manner.
- C.** Glue on the two key plates (018) so that they are centered on the inner vertical door frames between the bottom two horizontal mullions.
- D.** Glue the bookcase assembly onto the base assembly so that they are centered and flush at the back. It may be necessary to lightly sand the area where these two assemblies are glued together to allow the glue to adhere properly.
- E.** Glue the escutcheon plates in place on the drawer. Glue in one post. Check that the hole in the post is facing the center of the plate. Put a drop of glue into the other hole and insert the end of the second post. Put one end of the handle (58) into the hole in this second post and gradually push the post in as you guide the other end of the handle into the hole in the first post. Use the same procedure for the second assembly.
- F.** Glue the key plate (018) onto the top center position on the drawer front.
- G.** Insert the adjustable shelves into their dadoes. They are usually positioned to line up with the three horizontal mullions. Insert the drawer and your bookcase is complete.