

COLLECTORS NO. 40079

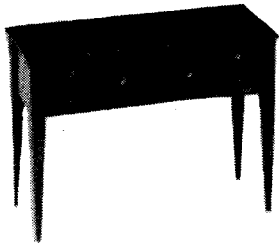

Hepplewhite
Huntboard
Circa 1780-1800

During the period from 1780 to 1840, three types of sideboards developed in this country: the long, or standard, sideboard; the shorter New England sideboard; and the huntboard. Their designs, for the most part, were based upon three styles: Hepplewhite, Sheraton, and American Empire.

The huntboard was used almost exclusively south of the Mason-Dixon Line and was derived from a simple plank, set up outside on trestles, that provided a place to lay out the food to feed the hunters as they returned from the hunt. As the Southern homes became larger and more fashionable, the huntboard was built as a piece of permanent furniture and was moved inside. When these pieces were still being used for their original purpose, to serve the hungry hunter, they were never found in the dining room, but were usually placed in the back hall, or even in one of the many outbuildings on the plantation.

The huntboards that have survived have finally been given a place of prominence in the home, but most are still fulfilling their original rolls as serving places for buffet meals.

ASSEMBLY AND FINISHING INSTRUCTIONS



AUTHENTIC REPRODUCTIONS IN MINIATURE

The X-ACTO® HOUSE OF MINIATURES COLLECTORS SERIES of furniture and accessories have all been carefully researched by specialists through major museum and library collections to assure the highest quality of authenticity in reproduction. Details are extraordinarily accurate to satisfy the most discriminating miniaturist.

All wood parts are machined to assure accurate and precise acceptance of each piece by another.

For a complete catalog of the X-ACTO® HOUSE OF MINIATURES furniture line and accessories, write to:
THE HOUSE OF MINIATURES
Customer Service - Catalog Dept.
80 Newbridge Road
Bergenfield, NJ 07621

INTRODUCTION

BEFORE STARTING

Identify and account for each part by placing it on the Layout Sheet (make sure the correct layout sheet is used when working on multi-kit Instruction Sheets). Should any parts be missing, send a post card to:

THE HOUSE OF MINIATURES
Customer Service - Parts Dept.
2000 Craftmark Center
Statesville, NC 28677-2000

Please print Name, Address, Part Number (Number from Layout Sheet) and Kit Name and Number on card when ordering.

SANDING

Before assembly, sand all the outer surfaces of individual parts with 220 grit sandpaper, or finer, sanded in the same direction as the wood grain until the surface is smooth. Take care not to round any edges or corners of the pieces. Finish sanding with 280 grit sandpaper.

PRE-ASSEMBLY

A. After sanding, check the proper location and fit of each part by assembling parts loosely, without gluing. Use the **DETAIL VIEWS** as a guide.

B. All parts for X-ACTO kits are made on precision

milling machines. When adjustments are required, sand to fit.

TOOLS AND MATERIALS

A. The following tools will be helpful in constructing this kit:

1. X-ACTO Professional Finishing Kit (or equivalent, see note)
2. Large Plastic Clamps, X-ACTO No. 7004
3. Small Plastic Clamps, X-ACTO No. 7003
4. 2" Sander, X-ACTO No. 7042
5. Pin Vise Set, X-ACTO No. 7144

B. The following materials will be needed to construct this kit:

1. X-ACTO Tinted Glue (see note)
2. Sandpaper - 220 and 280 grit
3. Small Artist's Brush

NOTE: The X-ACTO tinted glue is matched to the finish used in the Professional Finishing Kit. This will produce the authentic finish of the period in which the original furniture was produced. When not using X-ACTO glue follow manufacturer's directions.

GLUING

A. Glue should be applied in small amounts to surface being joined. When gluing dado joints ~~apply glue to~~ **dado only.**

B. To ensure a tight fit, squeeze excess glue out of the joints. Hold glued parts together with clamps, rubber bands or weights on the parts.

C. **Wipe off excess glue promptly.**

D. Be sure a glued assembly has dried thoroughly before adding parts.

FINISHING

The X-ACTO Professional Finishing Kit enables you to finish your furniture by the same process used by the professional furniture maker. The end result is what is important — there are easier methods, but none that will give the quality results that this process will. If you use a finish other than X-ACTO's, refer to the manufacturer's directions.

Layout Sheet

Kit 40079

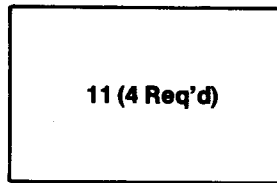
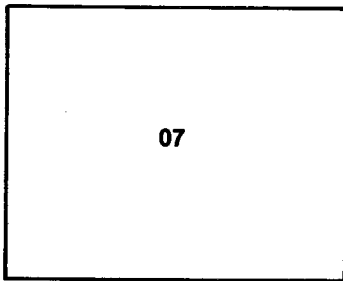
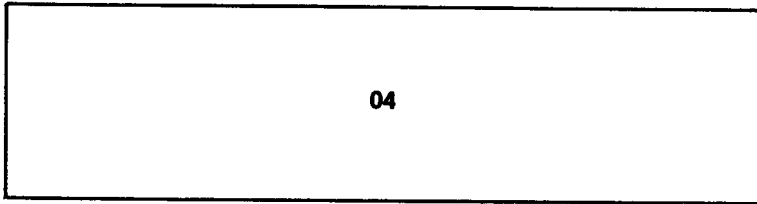
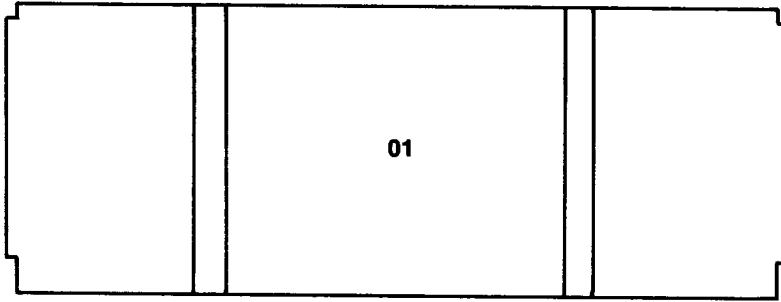
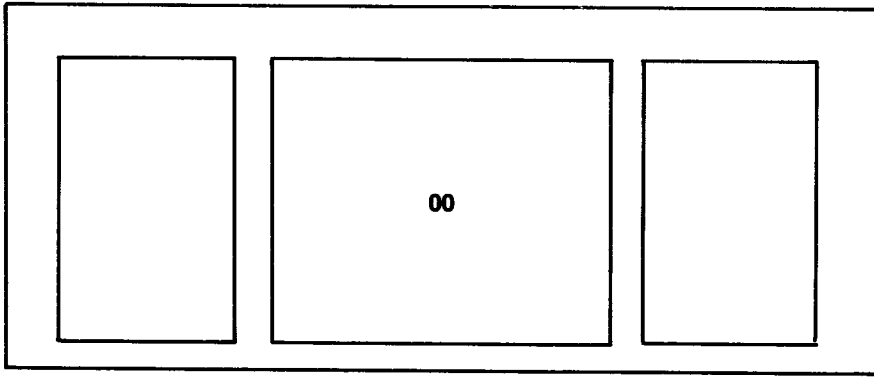

13 (8 Req'd.)

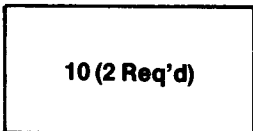

10 (2 Req'd)



14 (4 Req'd.)



06 (4 Req'd)

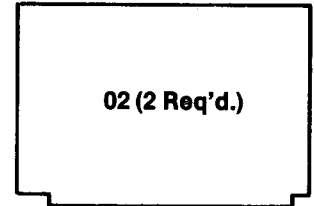

02 (2 Req'd.)

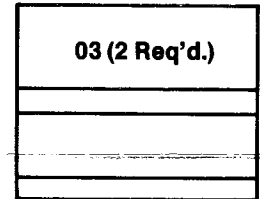

03 (2 Req'd.)

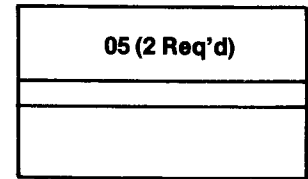

05 (2 Req'd)

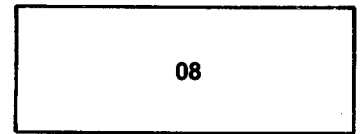

08

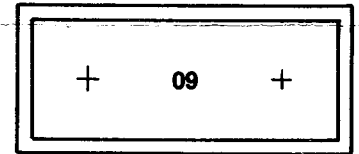

+ 09 +

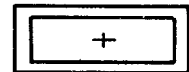

+ 12 (4 Req'd.)

HARDWARE

Quantity	Description
6	KNOB
6	PLATE

Detail Views

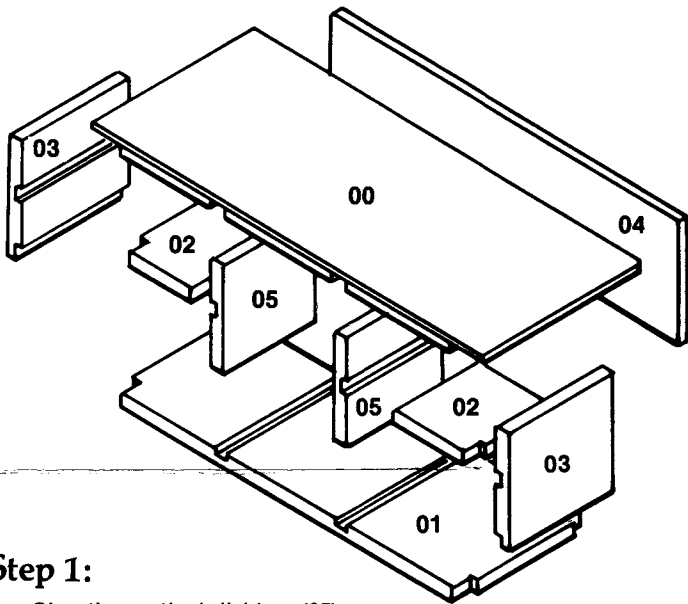

Step 1:

- A. Glue the vertical dividers (05) into the dadoes in the bottom (01) and into the dadoes in the top (00). The edges of the dividers should be flush front and back.
- B. Glue the horizontal dividers (02) into the center dividers (05) so they are flush at the front. Now glue the ends (03) in place. Their edges should be flush with the notches in (01) & (02).

- C. Glue the back (04) in place so that its ends are flush with the notches in (01) & (02) and with the raised portion of the top (00). There should now be a clear notch to receive the legs at the four corners of the case assembly.

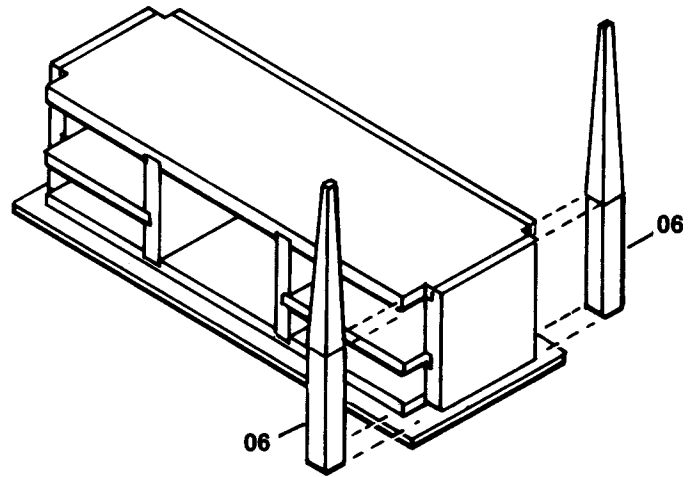

Step 2:

- A. Sand the outside of the case assembly.
- B. Glue the four legs (06) into the notches of the case assembly. Allow the glue to set firmly, and then check that the Huntboard sets level. Sand any leg that is too long.

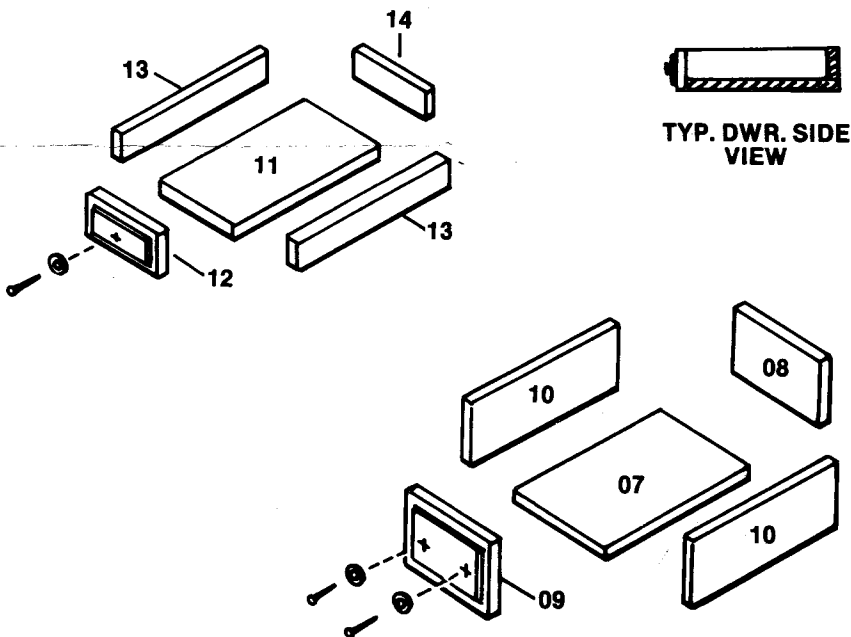

Step 3:

- A. **NOTE:** If the inside of the drawers are not to be stained, use white glue to assemble them.) Assemble the four side drawers by gluing the sides (13) and the back (14) on top of the bottom (11) so that the front and sides are flush. After the glue has set, check the fit of the drawers into their slots. Sand for a better fit if needed. Check the fit of the front (12). The front may be glued on now, or after staining and finishing.
- B. Assemble the center drawer using the same method that was used in "A". Check the detail drawing for the appropriate part numbers.
- C. Drill the holes for the hardware at the locations indicated on the Layout Sheet. Apply the stain and final finish at this time.
- D. Mount the hardware on the drawer fronts. A small amount of white glue should be applied to the back of the knob plates to hold them in place.

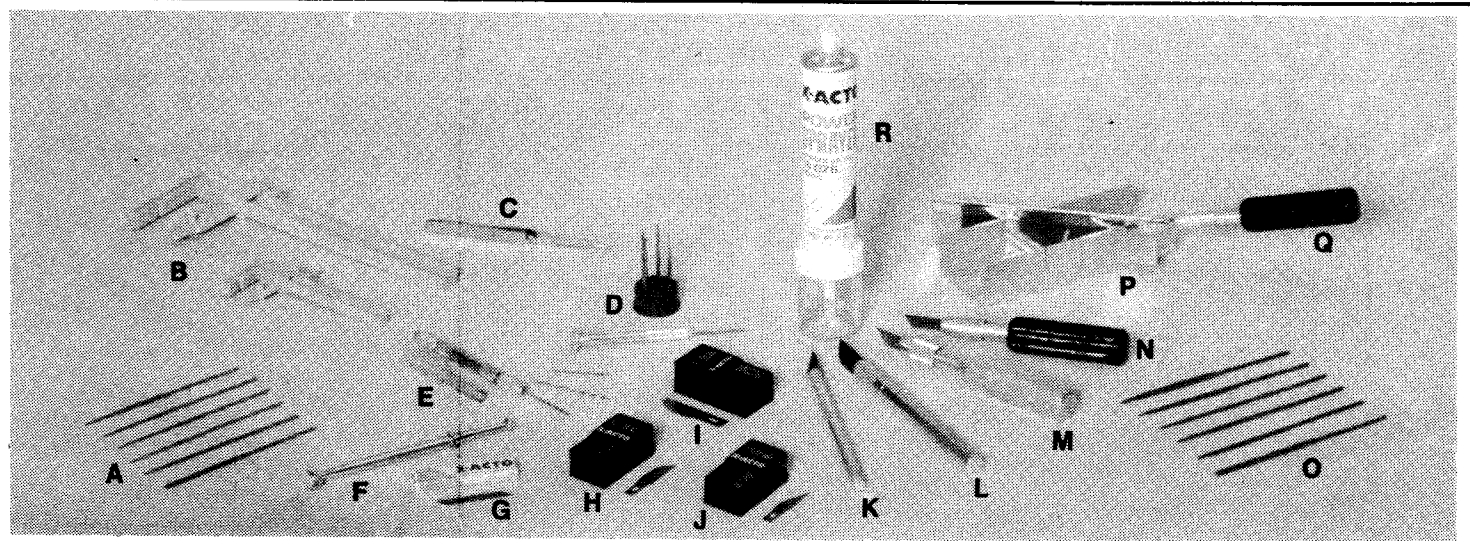

A. MINIATURE FILE SET

6 miniature needle files. 3 1/8" long. For intricate filing. Vinyl storage pouch. No. 7365

B. PLASTIC CLAMPS

Light duty plastic clamps for delicate work. Notched jaw allows grip of round parts. Smooth face prevents damage to workpiece.

Small plastic clamp. 3/4" opening with 1" throat depth.

2 per card: No. 7003

Large plastic clamp. 7/8" opening with 2 1/16" throat depth.

2 per card: No. 7004

C. SELF-CLOSING POINTED TWEEZER

Self-closing serrated points. Nickel-plated steel. 6 1/2."

Carded: No. 7337

D. SCREWDRIVER WITH INTERCHANGEABLE BLADES

Aluminum handle and chuck and 5 steel screwdriver blades sizes .040" through .100." Notched shank for greater torque. Storage base.

Carded: No. 7070

E. PIN VISE SET

Includes double-ended pin vise, vise bit guard and 3 assorted drill bits.

Carded: No. 7144

F. PARTPICKER

For small hard-to-handle pieces. Smooth one-handed action.

Carded: No. 7380

G. No. 13 BLADE

Precision saw cutting. 5 blades. Carded: No. 213

H. No. 10 BLADE

For fine general cutting, carving, correcting stencils.

Safety dispenser of 10 blades. Carded: No. 410

I. No. 22 BLADE

General shaping, whittling, trimming, removing excess flashing. Safety dispenser of 10 blade. Carded: No. 422

J. No. 11 BLADE

Extremely sharp point for fine angle cutting and stripping.

Safety dispenser of 10 blades. Carded: No. 411

K. No. 1 KNIFE

Aluminum handle 4 1/8" long with No. 11 blade. Carded: No. 3201

L. No. 2 KNIFE

Aluminum handle 5" long with No. 22 blade. Carded: No. 3202

M. No. 6 KNIFE

Aluminum handle 4 3/4" long with No. 24 blade. Carded: No. 3206

N. No. 5 KNIFE

Plastic handle with metal blade lock, 4 1/4" long with No. 19 blade.

Carded: No. 3205

O. MINIATURE NEEDLE RASPS

6 assorted rasps. For rough shaping of wood or plastic.

4 3/4" long. Vinyl storage pouch. No. 7366

P. MITRE BOX

Aluminum 3/4" x 1 3/4" capacity. 6" long. With two 45° and one 90° cutting slots. Carded: No. 7533

Q. EXTRA-FINE RAZOR SAW

1 1/4" deep with cutting edge 5 1/2" long and 54 teeth per inch for extra fine precision. For use with No. 7533 mitre box. Carded: No. 7535

R. POWER SPRAYER

Push-button action sprays evenly. Includes a one ounce jar and propellant to spray on intricate or flat surfaces up to 16 ounces of liquid materials. Carded: No. 43561

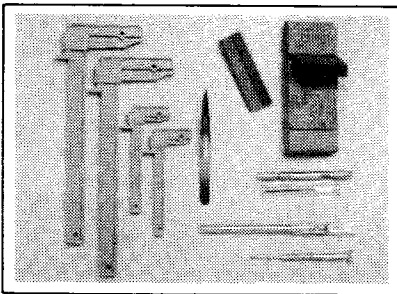

MINIATURIST'S TOOL SET

Basic tools for assembling miniatures, models and working with small parts. 4 clamps, tweezer, pin vise with 3 bits, 2 sanders, screwdriver and No. 1 Knife in fitted tray. No. 43910

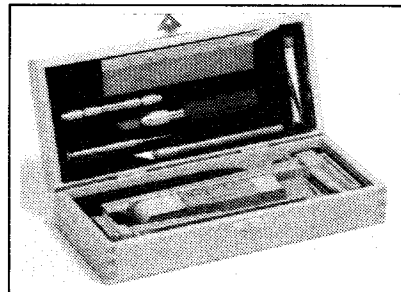

DELUXE MINIATURIST'S TOOL CHEST

Fitted wooden chest contains precision tools for assembling miniatures, models and working with small parts: razor saw blade, mitre box, 4 clamps, pin vise and 3 bits, Nos. 1 and 5 Knives, sanders and screwdriver. Boxed: No. 43911