

COLLECTORS NO. 40073

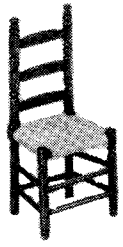

Slat Back Chair

Massachusetts:
Circa 1700

Chairs of this general style had many names. Slat Back or Ladder Back are two of the more popular designations. Today, they are most commonly attributed to the Shakers; but they were made by many cabinetmakers and turners.

Their designs were as varied as the number of builders, each of which had his own design. The general styling - and the shape of the slats - was also influenced by regional tastes. Some were very plain and straight, while others featured very ornate turnings.

The seats were almost exclusively woven, either with rush and cane or with brightly-colored woven tapes.

The Shakers were the largest producers of these chairs during the peak of their existence - supplying not only their own needs but also selling them to others outside of their world.

The wood used in the chairs sold outside the Shaker world was more common, e.g., maple and birch, than that used in the chairs for their own use. The slats in those made for themselves were often made of curly maple, burl wood or other exotically-grained wood.

This and the Windsor chair are the two most popular chairs of the Colonial period.

ASSEMBLY AND FINISHING INSTRUCTIONS



AUTHENTIC REPRODUCTIONS IN MINIATURE

The X-ACTO® House of Miniature® Collectors Series of furniture and accessories have all been carefully researched by specialists through major museum and library collections to assure the highest quality of authenticity in reproduction. Details are extraordinarily accurate to satisfy the most discriminating miniaturist.

All wood parts are machined to assure accurate and precise acceptance of each piece by another.

For a complete catalog of the X-ACTO® HOUSE OF MINIATURES furniture line and accessories, write to:

THE HOUSE OF MINIATURES
Customer Service - Catalog Dept.
80 Newbridge Road
Bergenfield, NJ 07621

INTRODUCTION

BEFORE STARTING

Identify and account for each part by placing it on the Layout Sheet (make sure the correct layout sheet is used when working on multi-kit Instruction Sheets). Should any parts be missing, send a post card to:

THE HOUSE OF MINIATURES
Customer Service - Parts Dept.
2000 Craftmark Center
Statesville, NC 28677-2000

Please print Name, Address, Part Number (Number from Layout Sheet) and Kit Name and Number on card when ordering.

SANDING

Before assembly, sand all the outer surfaces of individual parts with 220 grit sandpaper, or finer, sanded in the same direction as the wood grain until the surface is smooth. Take care not to round any edges or corners of the pieces. Finish sanding with 280 grit sandpaper.

PRE-ASSEMBLY

A. After sanding, check the proper location and fit of each part by assembling parts loosely, without gluing. Use the DETAIL VIEWS as a guide.

B. All parts for X-ACTO kits are made on precision milling machines. When adjustments are required, sand to fit.

TOOLS AND MATERIALS

A. The following tools will be helpful in constructing this kit:

1. X-ACTO #1 Knife
2. X-ACTO Professional Finishing Kit (or equivalent, see note)

B. The following materials will be needed to construct this kit:

1. X-ACTO Tinted Glue (see note)
2. Sandpaper - 220 and 280 grit
3. White glue (or equivalent)
4. Small Artist's Brush

NOTE: The X-ACTO tinted glue is matched to the finish used in the Professional Finishing Kit. This will produce the authentic finish of the period in which the original Furniture was produced. When not using X-ACTO glue follow manufacturer's directions.

GLUING

A. Glue should be applied in small amounts to surface being joined. When gluing dado joints apply glue to dado only.

B. To ensure a tight fit, squeeze excess glue out of the joints. Hold glued parts together with clamps, rubber bands or weights on the parts.

C. Wipe off excess glue promptly.

D. Be sure a glued assembly has dried thoroughly before adding parts.

FINISHING

The X-ACTO Professional Finishing Kit enables you to finish your furniture by the same process used by the professional furniture maker. The end result is what is important — there are easier methods, but none that will give the quality results that this process will. If you use a finish other than X-ACTO's, refer to the manufacturer's directions.

Detail Views

KIT 40073

Layout Sheet

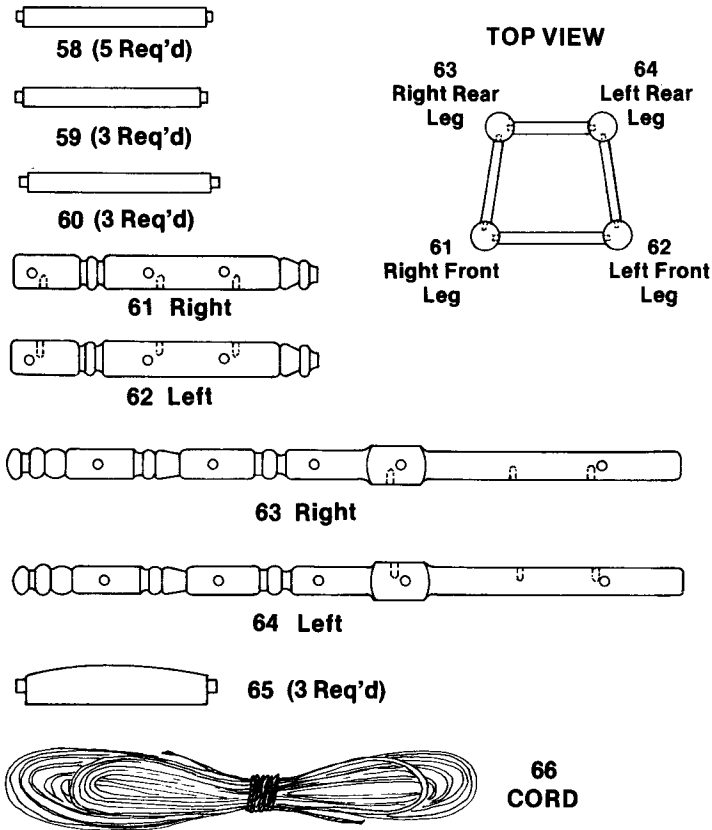

Step 2:

A. Join the front and rear leg assemblies together by inserting top spreaders (59) and center and lower spreaders (58) into the appropriate holes. (See note in Step 1 regarding these parts) Align assembly as shown in insert, and so it sets level.

B. Apply final finish.

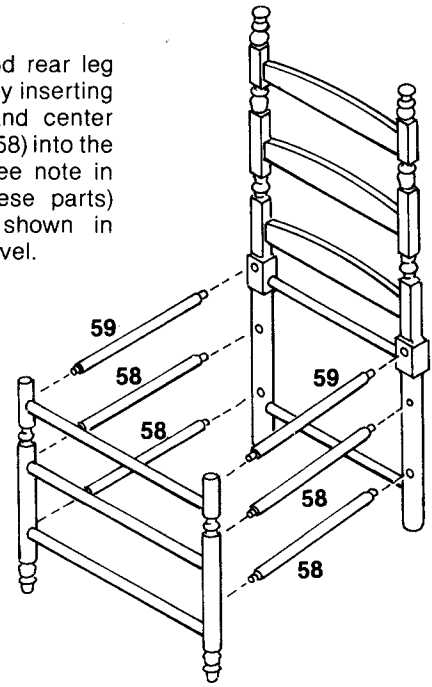
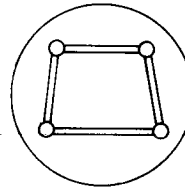

Step 3:

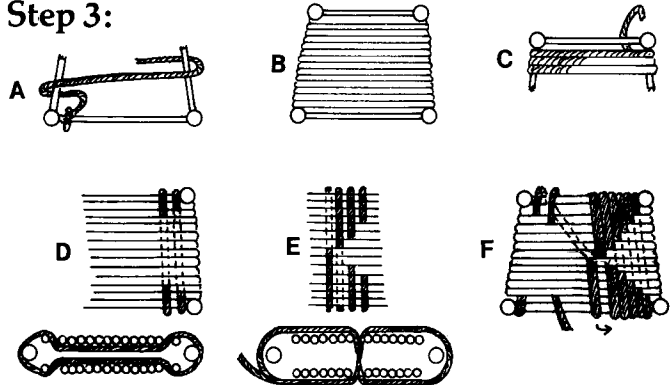

NOTE: A large eye needle is needed for these steps.

A. Tie one end of cord to front spreader. Run it under the side spreader, across to the other side and back under.

B. Continue with "A" until you have reached the back. Count the cords top and bottom. You should have an even number on both sides. Add or subtract a turn to make an even number.

C. Bring the end of the cord around the back spreader. It doesn't matter if you are now at either corner, top or bottom.

D. Going towards the front, bring the cord over the first side-to-side cord and under all except the last cord. Come up and over this cord and around front spreader. Repeat on the bottom

and come up and around the back spreader and across the first two cords, under all but last two, out and over. Keep repeating picking up one more cord each time until you finally go under only two cords.

E. Run cord between the center two cords, both top and bottom, then around the spreader.

F. Come back between two cords, either top or bottom, and run between the cords to the opposite outside corner and up and around the rear corner. Start as in "D" and work towards the center until you come under the center two cords on top and bottom. Repeat "E" until you are at the front spreader and then tie-off cord and tuck ends out of sight.

Step 1:

A. Glue the three slats (65), top spreader (59) and lower spreader (58) into the holes in the rear legs (63) & (64). Square assembly and set aside to dry. Note: Care must be taken when identifying parts 59 & 58. Part 58 is just slightly longer than part 59.

B. Glue front spreaders (60) into the front legs (61). The holes in these legs are in sets of two, 90 degrees apart. The correct holes for this step are the lower holes of each set. Allow glue to dry completely.

