

COLLECTORS NO. 40067

Chippendale
Desk on Frame

Circa 1680-1690



The desk as a separate piece of furniture was first made by American cabinetmakers between 1680 and 1690. Prior to that time a writing, or Bible box placed on a stool or small table served the function of a desk. The first desks reflected its origins and were two-part pieces consisting of larger versions of the writing box with a sloped, or slanted front placed on a topless frame.

The slant fronts were hinged at the bottom and opened to form a writing surface. This front was supported in the open position by two pull-out slides located on each side of a shallow drawer immediately below the writing surface. Leather, or fine fabric was often inset on the inner surface of the front to provide a smoother writing area.

The interior of the desk was constructed with numerous "pigeon" holes and drawers for storage of small items, documents, ledgers and writing material. Often one or more hidden compartments were built into this section.

The original of this desk was crafted in England in the Chippendale style. Its clean lines, lustrous mahogany finish, and gleaming brass hardware made it an attractive addition to almost any room in the house. In miniature it will also make an attractive addition to your collection.

ASSEMBLY AND FINISHING INSTRUCTIONS



AUTHENTIC REPRODUCTIONS IN MINIATURE.

The X-ACTO® House of Miniatures Collectors Series® of furniture and accessories have all been carefully researched by specialists through major museum and library collections to assure the highest quality of authenticity in reproduction. Details are extraordinarily accurate to satisfy the most discriminating miniaturist.

All wood parts are machined to assure accurate and precise acceptance of each piece by another.

For a complete catalog of the X-ACTO® HOUSE OF MINIATURES furniture line and accessories, write to:

THE HOUSE OF MINIATURES
Customer Service - Catalog Dept.
80 Newbridge Road
Bergenfield, NJ 07621

INTRODUCTION

BEFORE STARTING

Identify and account for each part by placing it on the Layout Sheet (make sure the correct layout sheet is used when working on multi-kit Instruction Sheets). Should any parts be missing, send a post card to:

THE HOUSE OF MINIATURES
Customer Service - Parts Dept.
2000 Craftmark Center
Statesville, NC 28677-2000

Please print Name, Address, Part Number (Number from Layout Sheet) and Kit Name and Number on card when ordering.

SANDING

Before assembly, sand all the outer surfaces of individual parts with 220 grit sandpaper, or finer, sanded in the same direction as the wood grain until the surface is smooth. Take care not to round any edges or corners of the pieces. Finish sanding with 280 grit sandpaper.

PRE-ASSEMBLY

A. After sanding, check the proper location and fit of each part by assembling parts loosely, without gluing. Use the **DETAIL VIEWS** as a guide.

B. All parts for X-ACTO kits are made on precision milling machines. When adjustments are required, sand to fit.

TOOLS AND MATERIALS

A. The following tools will be helpful in constructing this kit:

1. X-ACTO Two-inch Sander No. 7042
2. X-ACTO Large Clamp No. 7004
3. X-ACTO Pin Vise Set No. 7144
4. X-ACTO Professional Finishing Kit (or equivalent, see note)
5. X-ACTO Pliers No. 7504

B. The following materials will be needed to construct this kit:

1. X-ACTO Tinted Glue (see note)
2. Sandpaper - 220 and 280 grit
3. White glue (or equivalent)
4. Small Artist's Brush

NOTE: The X-ACTO tinted glue is matched to the finish used in the Professional Finishing Kit. This will produce the authentic finish of the period in which the original Furniture was produced. When not using X-ACTO glue follow manufacturer's directions.

GLUING

A. Glue should be applied in small amounts to surface being joined. When gluing dado joints apply glue to dado only.

B. To ensure a tight fit, squeeze excess glue out of the joints. Hold glued parts together with clamps, rubber bands or weights on the parts.

C. Wipe off excess glue promptly.

D. Be sure a glued assembly has dried thoroughly before adding parts.

FINISHING

The X-ACTO Professional Finishing Kit enables you to finish your furniture by the same process used by the professional furniture maker. The end result is what is important — there are easier methods, but none that will give the quality results that this process will. If you use a finish other than X-ACTO's, refer to the manufacturer's directions.

Detail Views

Kit 40067

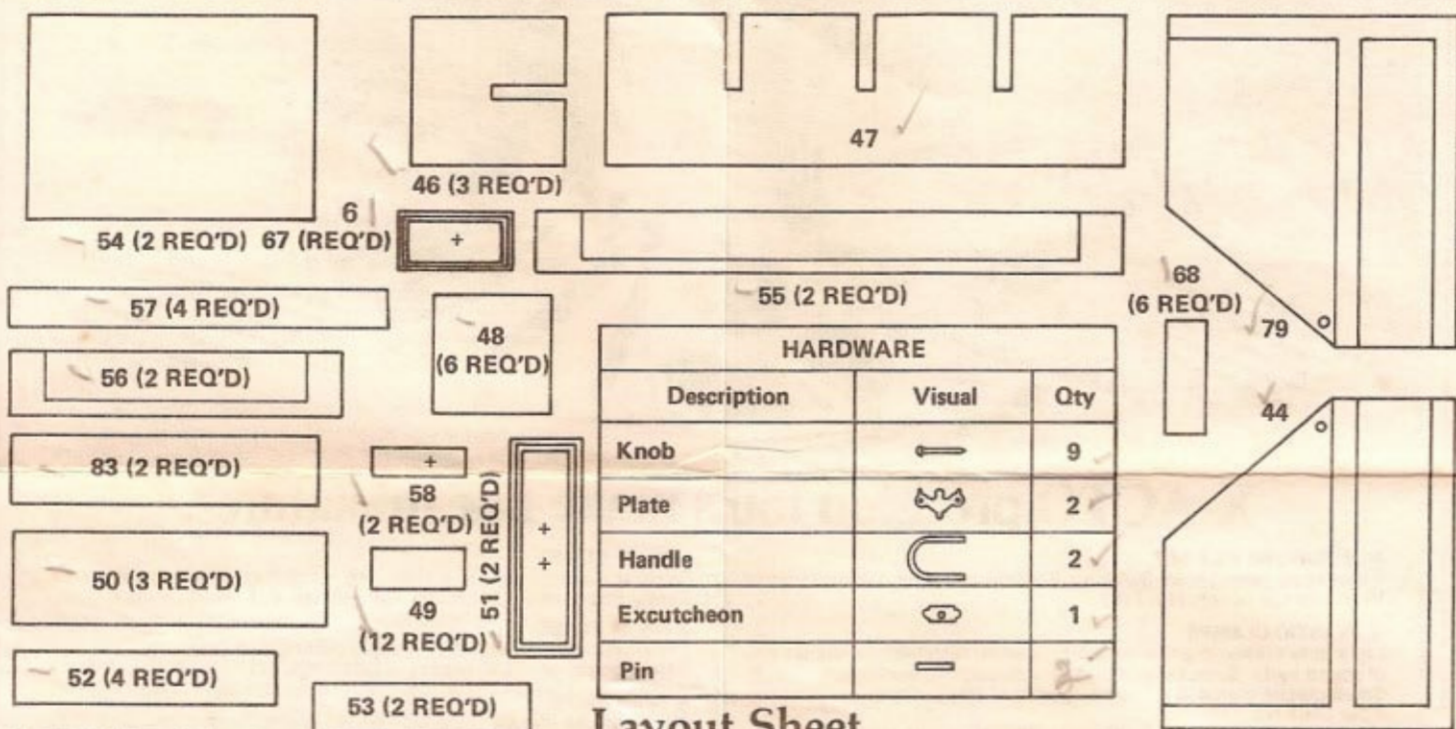

Layout Sheet

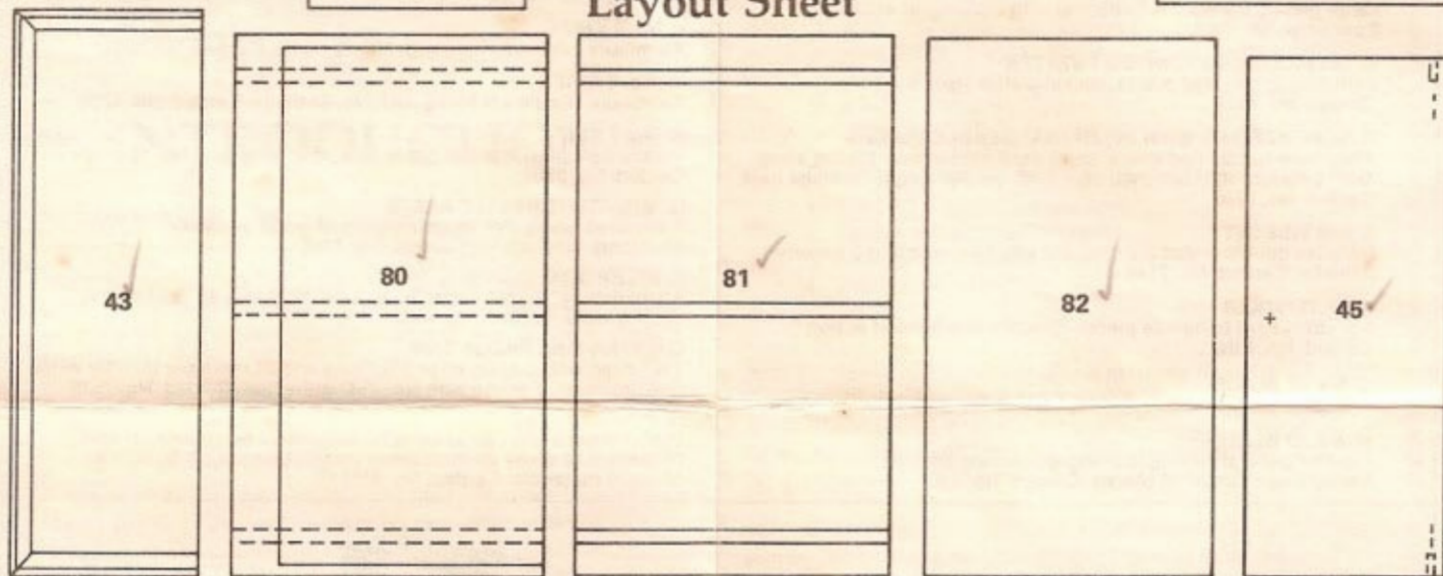

Step 1

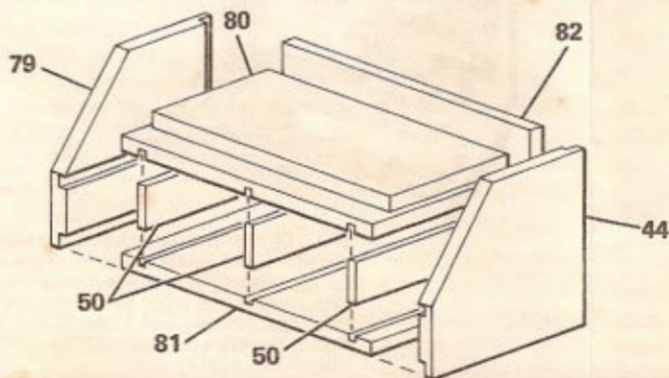

A. Sand all parts for proper fit prior to gluing.

B. Glue the vertical dividers (50) into the bottom (81) and the writing surface (80). Glue this assembly into the sides (44) & (79).

C. Glue the back (82) in place to align the entire assembly.

Detail Views

Kit 40067

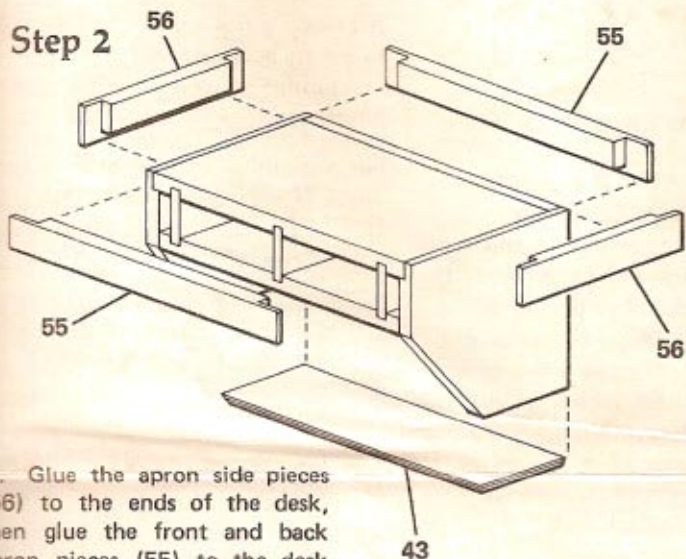

A. Glue the apron side pieces (56) to the ends of the desk, then glue the front and back apron pieces (55) to the desk and the end pieces. They should be centered so that they form a socket in each corner for the legs. Use a leg to check that they are spaced properly. Sand the outside corners smooth.

B. Glue the top (43) to the desk assembly so that its front edge is flush with the slanted edges of the desk sides. Sand the back of the assembly smooth.

Step 3

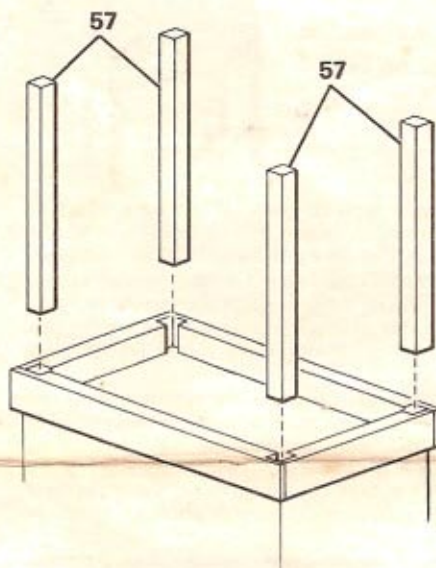

A. Glue the four legs (57) into the sockets formed by the apron. Square all of the legs and let the glue set before applying the final finish.

Step 4

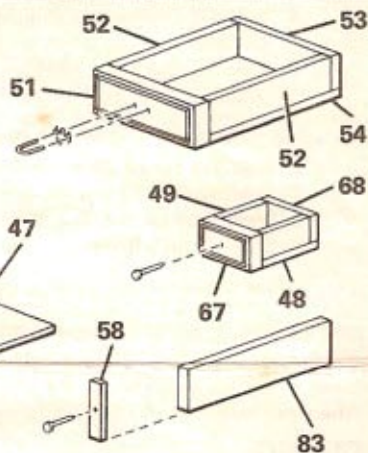
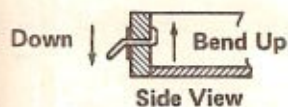

A. Glue the pigeonhole assembly together (Parts 46 & 47). Do not force the pieces or they may split. Sand to fit if necessary. Once it is dry, check its fit in the desk.

B. Glue the trim (58) to the ends of the slides (83). The bottom edge should be flush and the top projects to support the desk front.

C. Assemble the large drawers by gluing the sides (52) to the bottom (54) so the front edges and sides are flush. Glue the back (53) to the ends of the

sides (52) and to the bottom (54). If the interiors of the drawers are not to be stained apply the final finish to the drawer fronts (51) before completing the assembly.

D. Follow the same procedure as Step C for the small drawers using the appropriate parts as shown in the illustration.

E. After finishing use the guide marks on the Layout Sheet to locate where to drill the holes for the pulls and knobs. A drop of white glue on the back of the plates will hold them in place.

Step 5

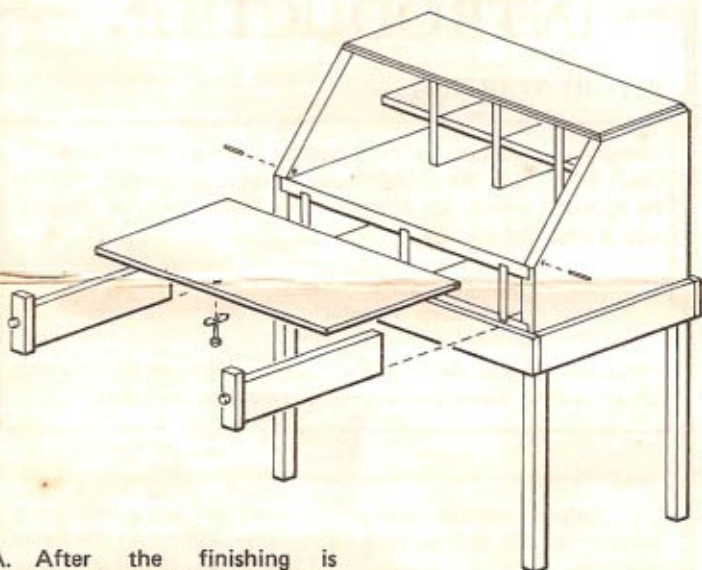

A. After the finishing is complete insert the pigeonhole assembly into the desk. A few drops of white glue will hold it in place.

B. Install the knob and plate on the desk front (45) and then install the front by inserting the pins through the holes in the sides. Re-drill the holes if they

have become clogged with finish. If the pins are too long cut them to the proper length.

C. Insert the slides and drawers.