

COLLECTORS NO. 40060



Single Low Post Bed

Circa 1760-1770

The original of this bed was made in the Colonies, probably Rhode Island, in the Chippendale style. Beds of this type have had a higher survival rate than the larger four-posted beds since they continued to have a practical use as beds for the children, or at least were far easier to store away.

The original need for a smaller bed was much the same as it is today. They were used for the children's rooms or the smaller guest bedrooms. Taverns also provided many of these beds for the traveler, but in this case they were usually rented out at a premium since they would only accommodate one person. The larger beds in the taverns often were rented to three or four people at a time.

The original of this bed was made of mahogany with a sturdy rope frame used to support the mattress. The turnings on the four posts were more distinctive than the more usual "cannon-ball" turnings.

ASSEMBLY AND FINISHING INSTRUCTIONS



AUTHENTIC REPRODUCTIONS IN MINIATURE

The X-ACTO® House of Miniatures® Collectors Series of furniture and accessories have all been carefully researched by specialists through major museum and library collections to assure the highest quality of authenticity in reproduction. Details are extraordinarily accurate to satisfy the most discriminating miniaturist.

All wood parts are machined to assure accurate and precise acceptance of each piece by another.

For a complete catalog of the X-ACTO® HOUSE OF MINIATURES furniture line and accessories, write to:

THE HOUSE OF MINIATURES
Customer Service - Catalog Dept.
80 Newbridge Road
Bergenfield, NJ 07621

INTRODUCTION

BEFORE STARTING

Identify and account for each part by placing it on the Layout Sheet (make sure the correct layout sheet is used when working on multi-kit Instruction Sheets). Should any parts be missing, send a post card to:

THE HOUSE OF MINIATURES
Customer Service - Parts Dept.
2000 Craftmark Center
Statesville, NC 28677-2000

Please print Name, Address, Part Number (Number from Layout Sheet) and Kit Name and Number on card when ordering.

SANDING

Before assembly, sand all the outer surfaces of individual parts with 220 grit sandpaper, or finer, sanded in the same direction as the wood grain until the surface is smooth. Take care not to round any edges or corners of the pieces. Finish sanding with 280 grit sandpaper.

PRE-ASSEMBLY

A. After sanding, check the proper location and fit of each part by assembling parts loosely, without gluing. Use the **DETAIL VIEWS** as a guide.

B. All parts for X-ACTO kits are made on precision milling machines. When adjustments are required, sand to fit.

TOOLS AND MATERIALS

A. The following tools will be helpful in constructing this kit:

1. Pin Vise X-ACTO No. 7144
2. One-inch Sander, X-ACTO No. 7041
3. Large Clamp, X-ACTO No. 4004
4. X-ACTO Professional Finishing Kit (or equivalent, see note)

B. The following materials will be needed to construct this kit:

1. X-ACTO Tinted Glue (see note)
2. Waxed paper
3. Sandpaper - 220 and 280 grit
4. Small Artist's Brush

NOTE: The X-ACTO tinted glue is matched to the finish used in the Professional Finishing Kit. This will produce the authentic finish of the period in which the original Furniture was produced. When not using X-ACTO glue follow manufacturer's directions.

GLUING

A. Glue should be applied in small amounts to surface being joined. When gluing dado joints apply glue to dado only.

B. To ensure a tight fit, squeeze excess glue out of the joints. Hold glued parts together with clamps, rubber bands or weights on the parts.

C. Wipe off excess glue promptly.

D. Be sure a glued assembly has dried thoroughly before adding parts.

FINISHING

The X-ACTO Professional Finishing Kit enables you to finish your furniture by the same process used by the professional furniture maker. The end result is what is important — there are easier methods, but none that will give the quality results that this process will. If you use a finish other than X-ACTO's, refer to the manufacturer's directions.

Detail Views

KIT 40060

Step 1

A. Utilizing Alignment Pattern No. 1, glue ends (61) to sides (44).

B. After glue sets, drill holes for string with a No. 52 drill bit utilizing Alignment Pattern No. 1.

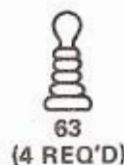
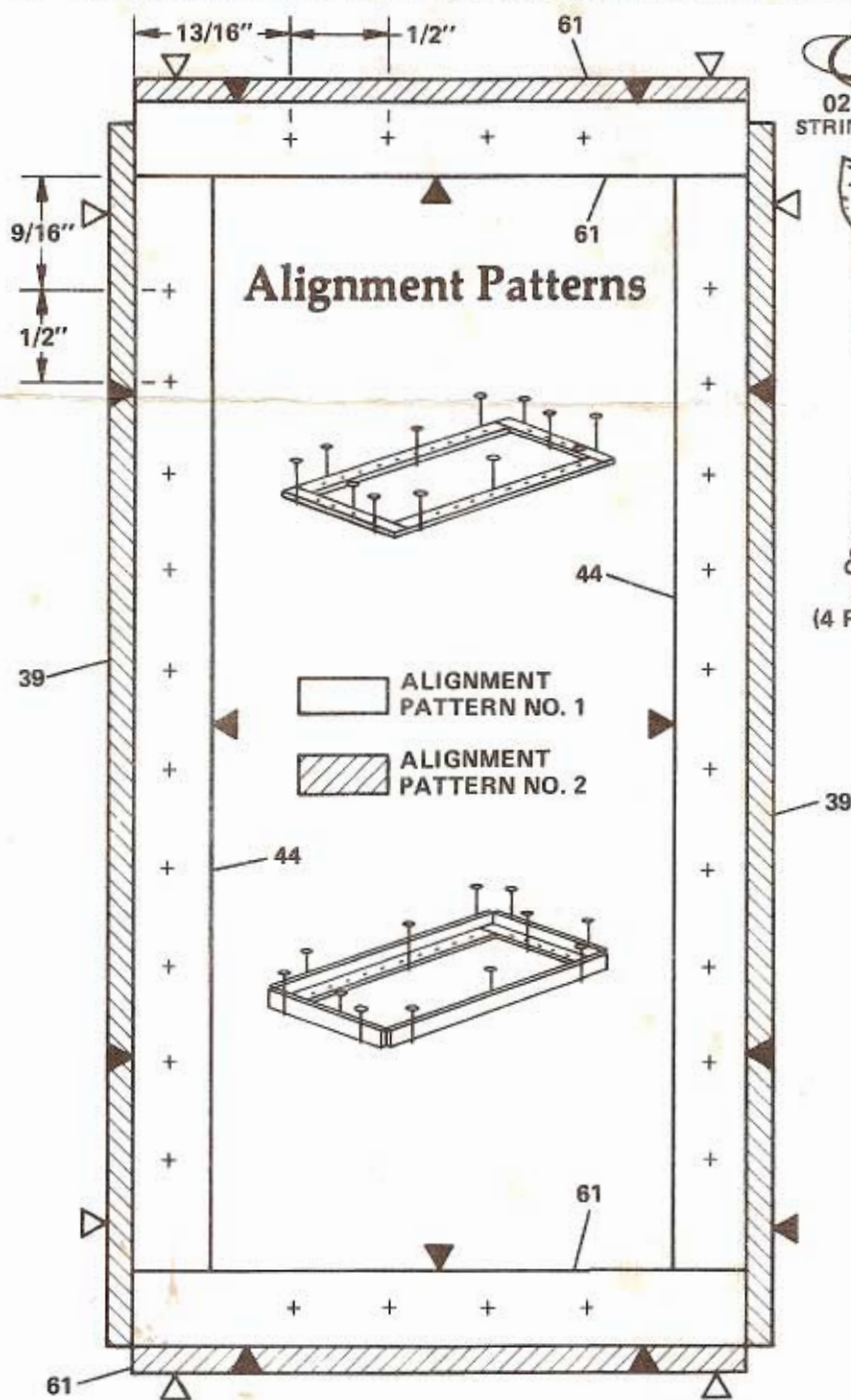
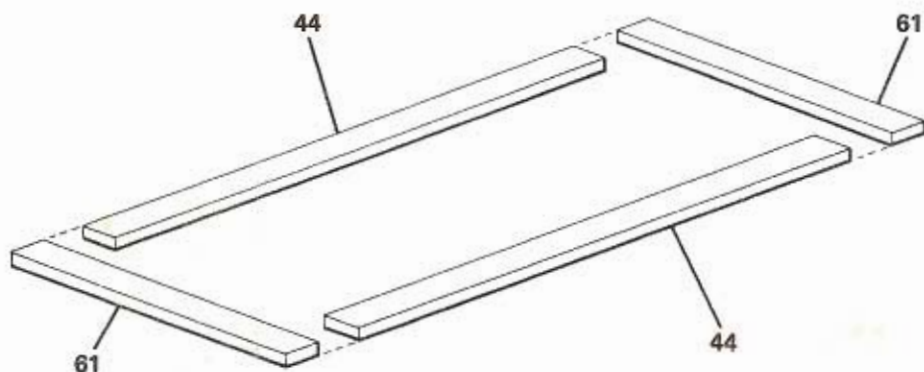

Layout Sheet

62
61 (4 REQ'D)
39 (2 REQ'D)
44 (2 REQ'D)

Detail Views

KIT 40060

Step 2

A. Utilizing Alignment Pattern No. 2, glue side rails (39), footboard (61), and lower headboard (61) to frame assembly. Notches formed at corners by this step will be longer at the head of the bed than at the foot.

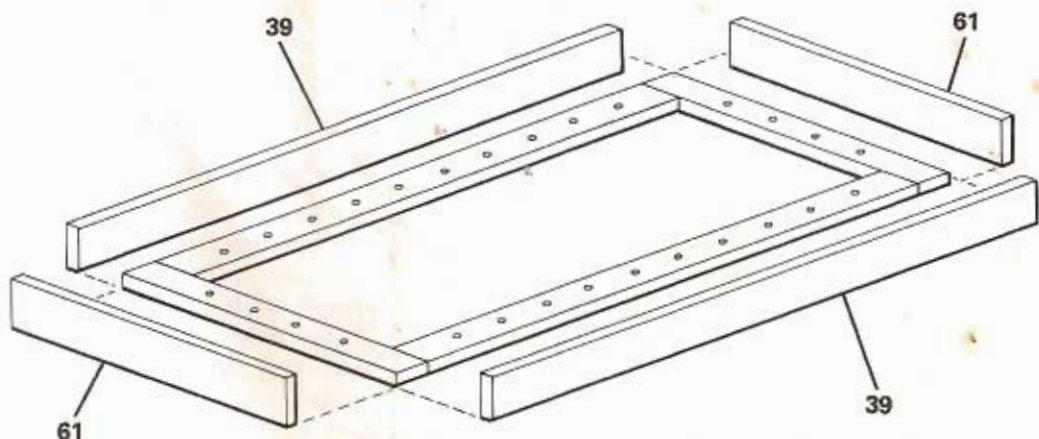

Step 3

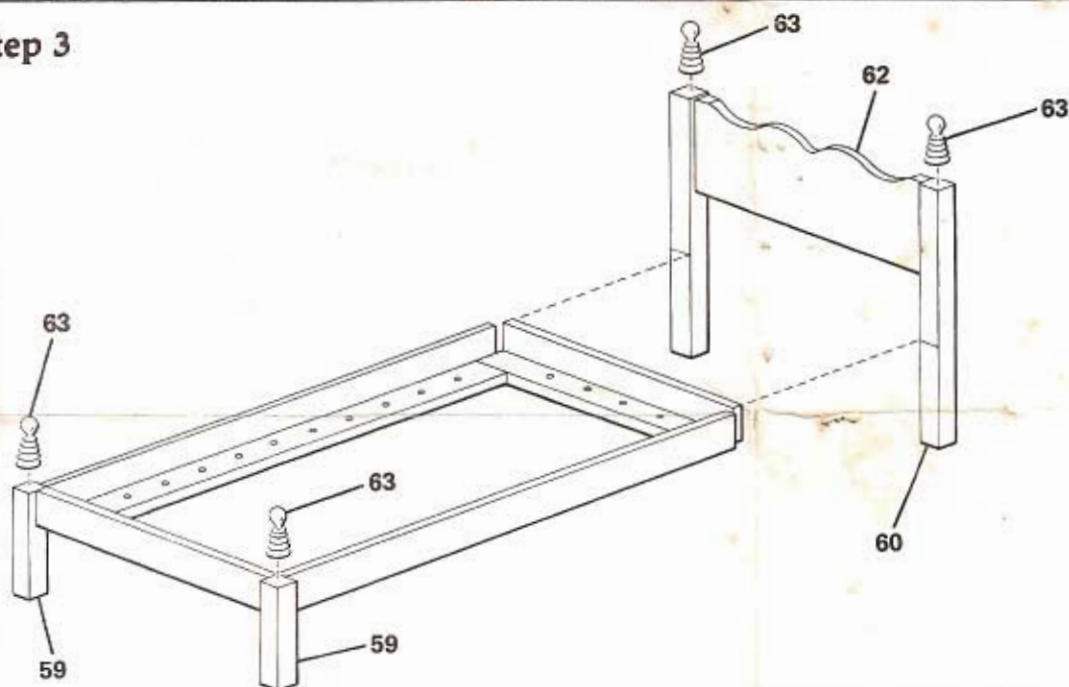

A. Glue front legs (59) into notches flush with top of rails. Glue knob (63) to top of legs.

B. Hold rear legs (60) along side front legs (59) and mark height of side rail (39).

C. Glue rear legs in place using mark made in Step B as a guide.

D. Glue headboard (62) between legs and flush with top of legs.

E. Glue knob (63) to top of rear posts (60).

F. Apply Final Finish at this time.

Step 4

NOTE: Dip one end of string in glue, remove excess, and allow to dry. This will assist in the stringing procedure.

A. Tie a knot in the other end of the string and reeve glue tip back and forth across frame keeping string tight. Tie off end of string with a knot.

B. Repeat Step 4A for stringing in opposite direction, weaving string over and under string installed in Step 4A.

C. Place mattress (30) in position on bed.

