

COLLECTORS NO. 40051



Cupboard Top
Circa 1770

Space was always in demand in the Colonial households. Decorative tops such as the one we have reproduced in miniature were built to fit all styles of bases ranging from simple chest to high styled sideboards. The shelves usually were used to display the housewife's most prized table service.

The overall designs of these tops varied with the cabinetmaker's whims and his customer's taste. The plate groove near the rear of each shelf was a must however. Treatment of the sides and cornices varied considerably. The one we have reproduced in miniature has a straight, relatively basic main body with a heavily molded cornice. The severity is broken by the decorative treatment of the frieze.

Other versions of this type of top were often very elaborate with heavily "C" and "S" scrolled sides and friezes. The design used on the frieze was sometimes also carried through to a treatment on the fronts of each shelf. Most tops were not attached to the base and few utilized backs.

ASSEMBLY AND FINISHING INSTRUCTIONS



AUTHENTIC REPRODUCTIONS IN MINIATURE

The X-ACTO® House of Miniatures® Collectors Series of furniture and accessories have all been carefully researched by specialists through major museum and library collections to assure the highest quality of authenticity in reproduction. Details are extraordinarily accurate to satisfy the most discriminating miniaturist.

All wood parts are machined to assure accurate and precise acceptance of each piece by another.

For a complete catalog of the X-ACTO® HOUSE OF MINIATURES furniture line and accessories, write to:

X-ACTO® THE HOUSE OF MINIATURES Dept. KIT
45-35 Van Dam Street
Long Island City,
New York 11101

Please include \$1.00 for postage and handling.

INTRODUCTION

BEFORE STARTING

Identify and account for each part by placing it on the Layout Sheet (make sure the correct layout sheet is used when working on multi-kit Instruction Sheets). Should any parts be missing, send a post card to:

X-ACTO/The House of Miniatures
45-35 Van Dam Street
Long Island City, N.Y. 11101

Please print Name, Address, Part Number (Number from Layout Sheet) and Kit Name and Number on card when ordering.

SANDING

Before assembly, sand all the outer surfaces of individual parts with 220 grit sandpaper, or finer, sanded in the same direction as the wood grain until the surface is smooth. Take care not to round any edges or corners of the pieces. Finish sanding with 280 grit sandpaper.

PRE-ASSEMBLY

- After sanding, check the proper location and fit of each part by assembling parts loosely, without gluing. Use the **DETAIL VIEWS** as a guide.
- All parts for X-ACTO kits are made on precision milling machines. When adjustments are required, sand to fit.

TOOLS AND MATERIALS

A. The following tools will be helpful in constructing this kit:

- Two-inch Sander, X-ACTO No. 7042
- Large Clamp, X-ACTO No 4004
- X-ACTO Professional Finishing Kit (or equivalent, see note)

B. The following materials will be needed to construct this kit:

- X-ACTO Tinted Glue (see note)
- Sandpaper - 220 and 280 grit
- Steel Wool - Grade 0000
- Small Artist's Brush

NOTE: The X-ACTO tinted glue is matched to the finish used in the Professional Finishing Kit. This will produce the authentic finish of the period in which the original Furniture was produced. When not using X-ACTO glue follow manufacturer's directions.

GLUING

- Glue should be applied in small amounts to surface being joined. When gluing dado joints apply glue to dado only.
- To ensure a tight fit, squeeze excess glue out of the joints. Hold glued parts together with clamps, rubber bands or weights on the parts.
- Wipe off excess glue promptly.
- Be sure a glued assembly has dried thoroughly before adding parts.

FINISHING

The X-ACTO Professional Finishing Kit enables you to finish your furniture by the same process used by the professional furniture maker. The end result is what is important - there are easier methods, but none that will give the quality results that this process will. If you use a finish other than X-ACTO's, refer to the manufacturer's directions.

Detail Views

Kit 40051

Layout Sheet

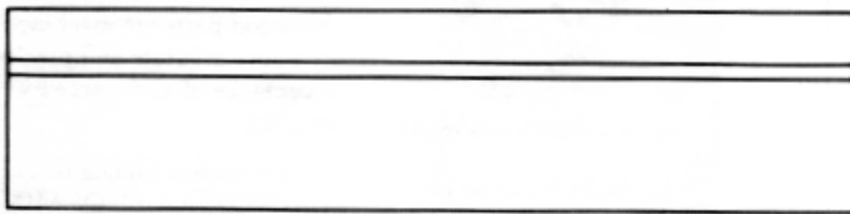

03
(2 REQ'D)



01

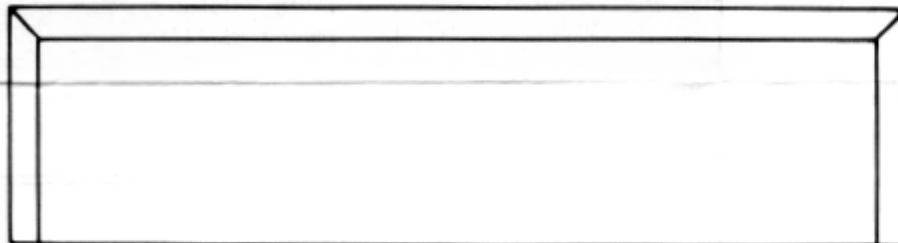

02



97
(2 REQ'D)



08
(3 REQ'D)

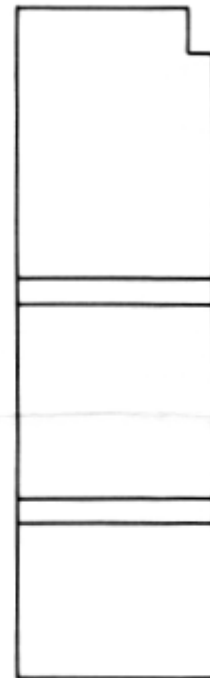

98

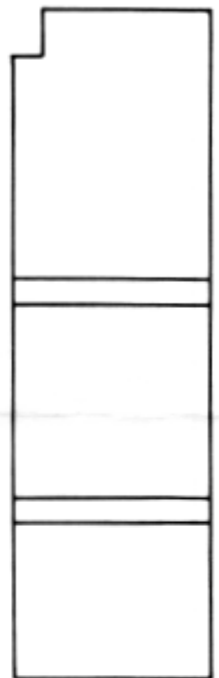

99

Step 1

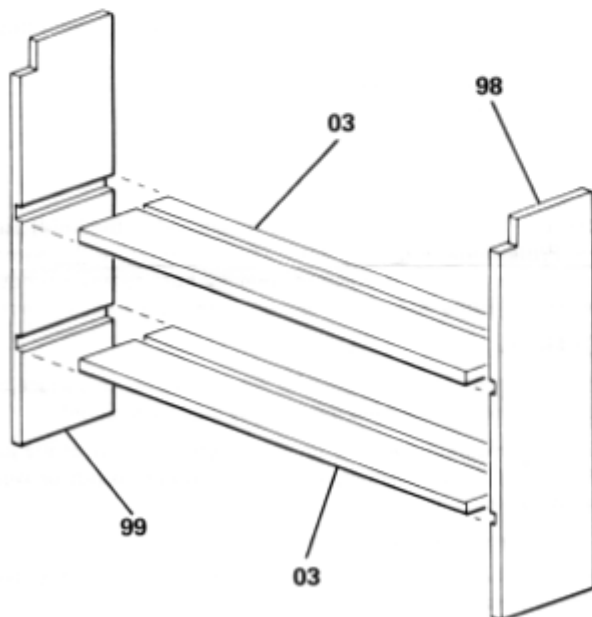

A. Glue shelves (03) into dadoes of sides (99) & (98). Plate groove should be up and to the rear. Square entire assembly.

Step 2

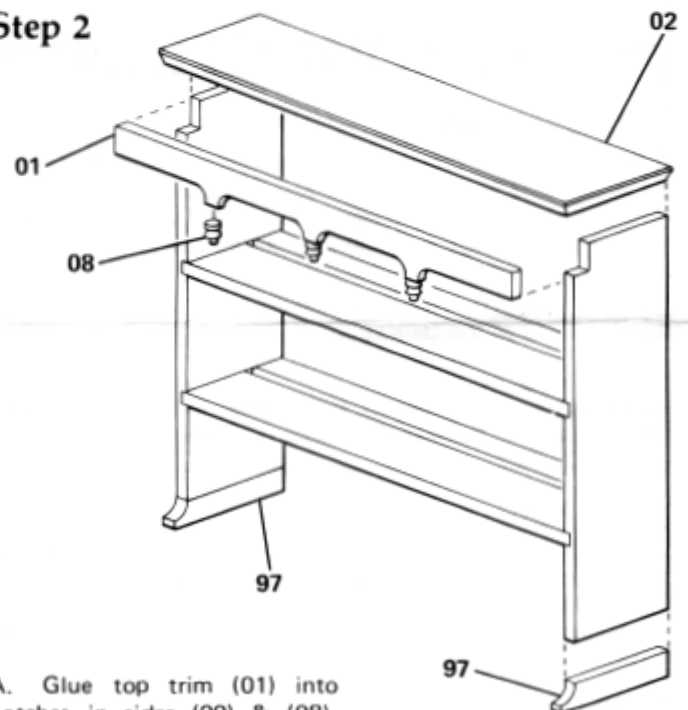

A. Glue top trim (01) into notches in sides (99) & (98).

B. Center and glue finials (08) to projections on top trim (01).

C. Center and glue shelf assembly to the top (02). Back should be flush.

D. Glue feet (97) to sides. They should be centered with backs flush.

E. Apply final finish.