

ASSEMBLY AND FINISHING INSTRUCTIONS

COLLECTORS NO. 40048

Chippendale
Breakfront
Circa 1760

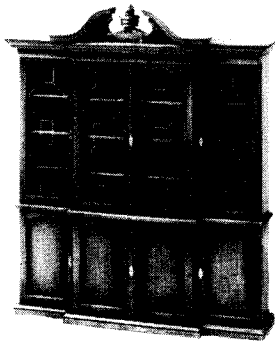

Breakfronts such as the one that ours was scaled from were massive and dominated the room in which they were placed. This example of 18th century

cabinet-making was made for an English manor house and eventually found a home in a collection in Rhode Island.

The massiveness of a piece like this was further accentuated by the wood paneled doors of its base and the treatment of its pediment and entablature. The broad expanse of glass in the upper doors toned down the mass somewhat and the original of this piece had the interior of the upper cupboard covered with pongee which further lightened its appearance.

Many versions of the breakfront were crafted both in England and in America in all types of woods. This particular piece was constructed of mahogany.

Most of these pieces were constructed in two pieces, upper and lower cabinets, and many had a removable cornice and pediment. This was necessary due to their weight and also to allow them to fit through the doorways.

The upper portion was used to display fine pieces of china and statuary while the lower portion provided space for storage of the table settings.



AUTHENTIC REPRODUCTIONS IN MINIATURE

The X-ACTO® House of Miniatures Collectors Series™ of furniture and accessories have all been carefully researched by specialists through major museum and library collections to assure the highest quality of authenticity in reproduction. Details are extraordinarily accurate to satisfy the most discriminating miniaturist.

All wood parts are machined to assure accurate and precise acceptance of each piece by another.

For a complete catalog of the X-ACTO® HOUSE OF MINIATURES furniture line and accessories, write to:

X-ACTO® THE HOUSE OF MINIATURES Dept. KIT
45-35 Van Dam Street
Long Island City,
New York 11101

Please include \$2.00 for postage and handling.

TOOLS AND MATERIALS

A. The following tools will be helpful in constructing this kit:

1. Two-inch Sander, X-ACTO No. 7042
2. Large Clamp, X-ACTO No. 7004
3. Small Clamp, X-ACTO No. 7003
4. X-ACTO Professional Finishing Kit (or equivalent, see note)

B. The following materials will be needed to construct this kit:

1. X-ACTO Tinted Glue (see note)
2. Waxed paper
3. Sandpaper - 220 and 280 grit
4. Steel Wool - Grade 0000
5. White glue (or equivalent)
6. Small Artist's Brush

NOTE: The X-ACTO tinted glue is matched to the finish used in the Professional Finishing Kit. This will produce the authentic finish of the period in which the original Furniture was produced. When not using X-ACTO glue follow manufacturer's directions.

GLUING

A. Glue should be applied in small amounts to surface being joined. When gluing dado joints apply glue to dado only.

B. To ensure a tight fit, squeeze excess glue out of the joints. Hold glued parts together with clamps, rubber bands or weights on the parts.

C. Wipe off excess glue promptly.

D. Be sure a glued assembly has dried thoroughly before adding parts.

FINISHING

The X-ACTO Professional Finishing Kit enables you to finish your furniture by the same process used by the professional furniture maker. The end result is what is important — there are easier methods, but none that will give the quality results that this process will. If you use a finish other than X-ACTO's, refer to the manufacturer's directions.

INTRODUCTION

BEFORE STARTING

Identify and account for each part by placing it on the Layout Sheet (make sure the correct layout sheet is used when working on multi-kit Instruction Sheets). Should any parts be missing, send a post card to:

X-ACTO/The House of Miniatures
45-35 Van Dam Street
Long Island City, N.Y. 11101

Please print Name, Address, Part Number (Number from Layout Sheet) and Kit Name and Number on card when ordering.

SANDING

Before assembly, sand all the outer surfaces of individual parts with 220 grit sandpaper, or finer, sanded in the same direction as the wood grain until the surface is smooth. Take care not to round any edges or corners of the pieces. Finish sanding with 280 grit sandpaper.

PRE-ASSEMBLY

A. After sanding, check the proper location and fit of each part by assembling parts loosely, without gluing. Use the **DETAIL VIEWS** as a guide.

B. All parts for X-ACTO kits are made on precision milling machines. When adjustments are required, sand to fit.

Layout Sheet

Kit 40048

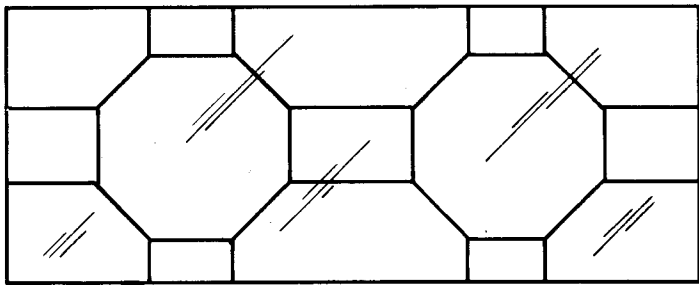

P/O 95 (4 REQ'D)



68

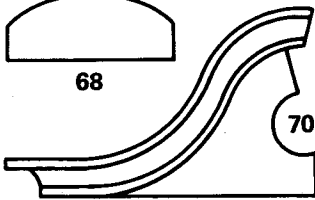

70

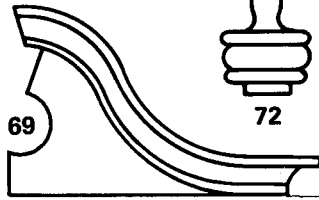

69



72



65



64 (2 REQ'D)

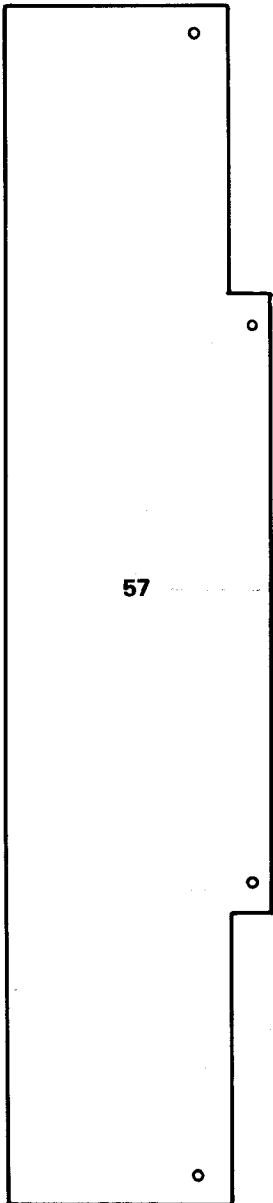

57

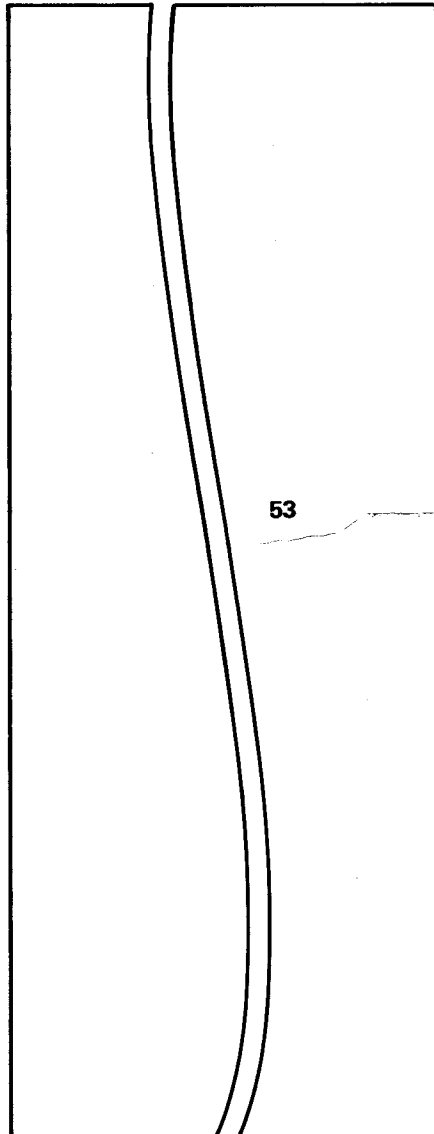

53

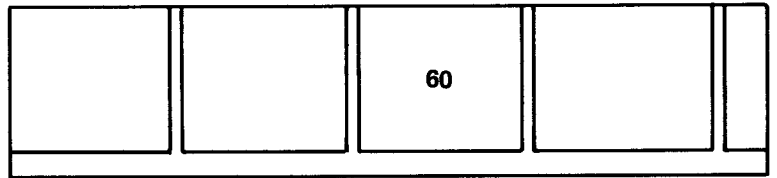

60

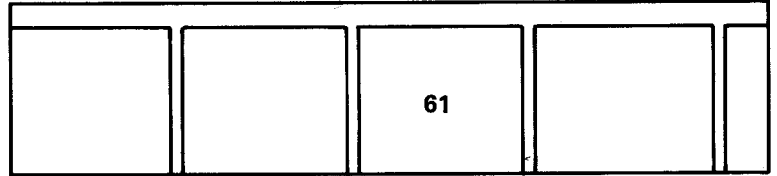

61

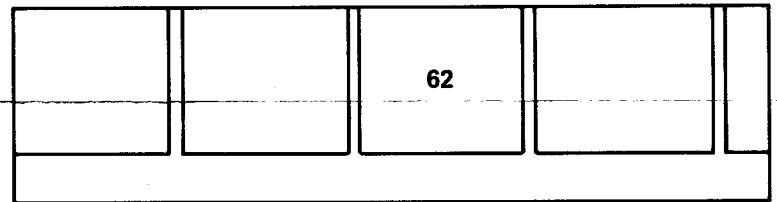

62

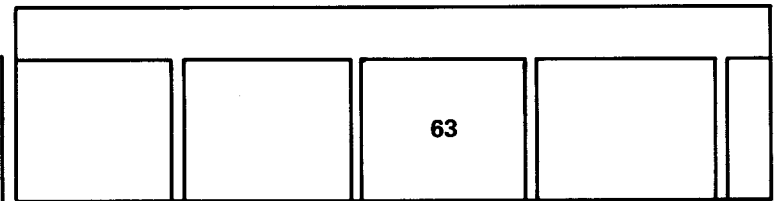

63

Step 4

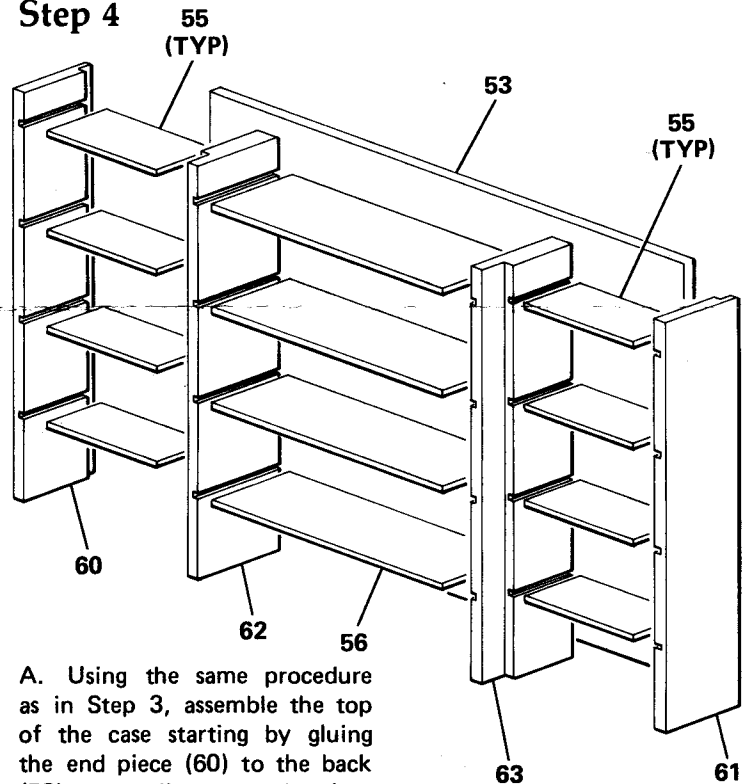

A. Using the same procedure as in Step 3, assemble the top of the case starting by gluing the end piece (60) to the back (53), proceeding across the piece using the parts indicated in the drawings. At each vertical divider check for squareness an alignment with the back.

Layout Sheet

Kit 40048

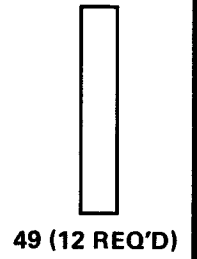
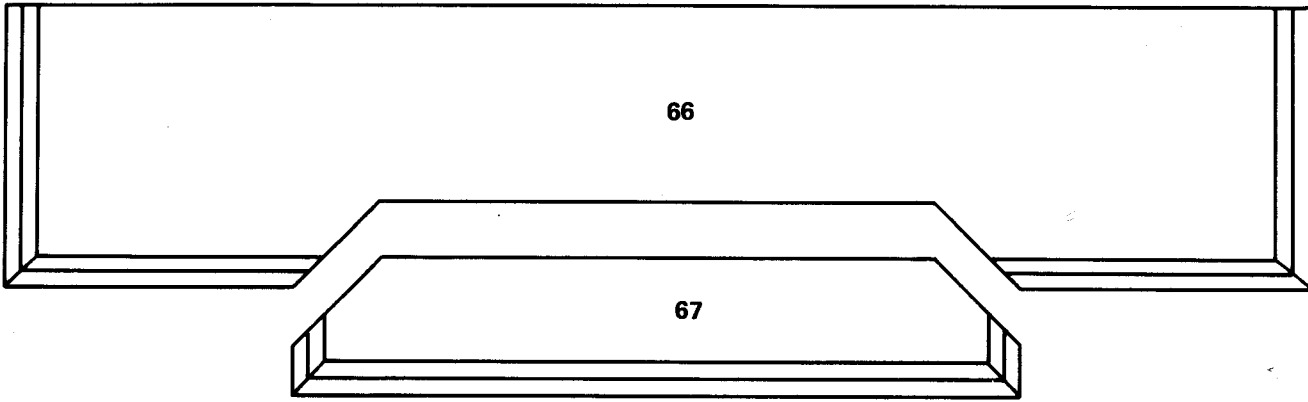

49 (12 REQ'D)

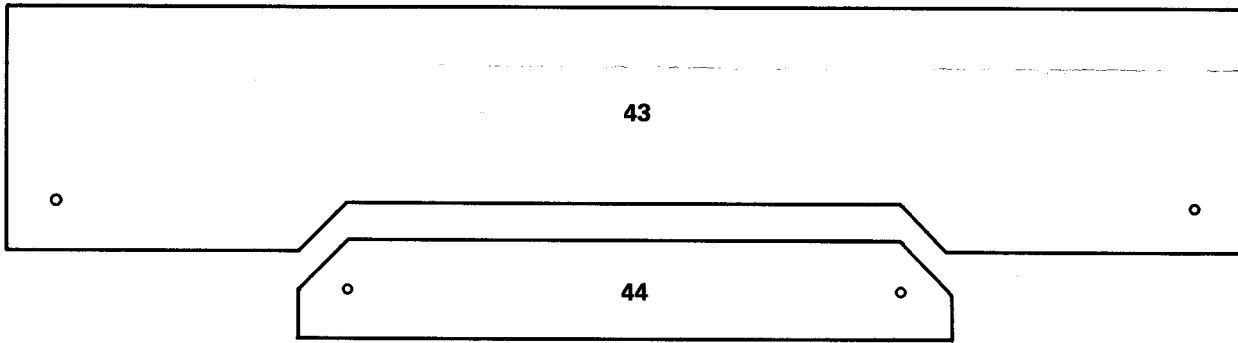

48 (4 REQ'D)

51 (2 REQ'D)

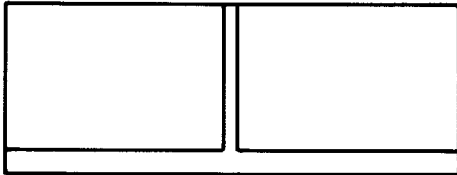

45 (4 REQ'D)



55 (10 REQ'D)



46 (4 REQ'D)

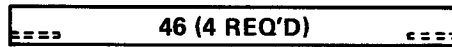

56 (5 REQ'D)

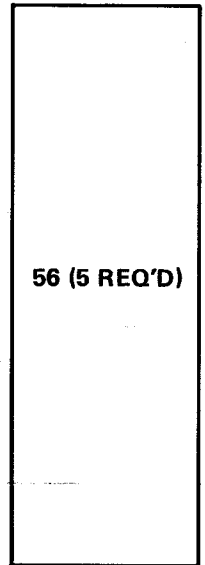

94

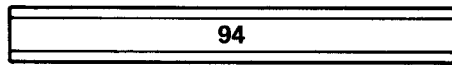

52 (2 REQ'D)

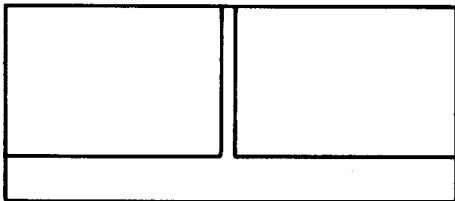

50

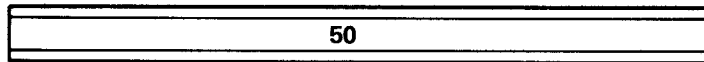

58 (4 REQ'D)



59 (4 REQ'D)



54

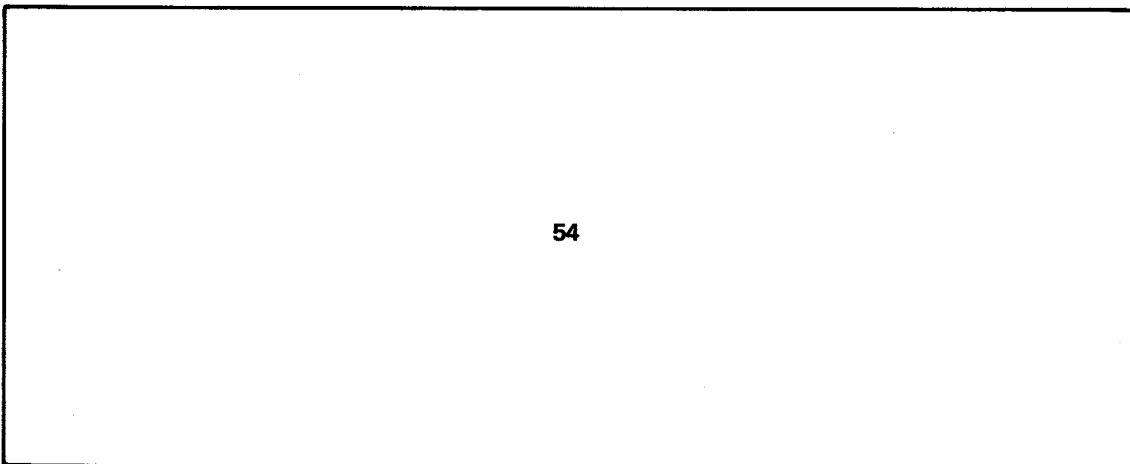

47 (4 REQ'D)

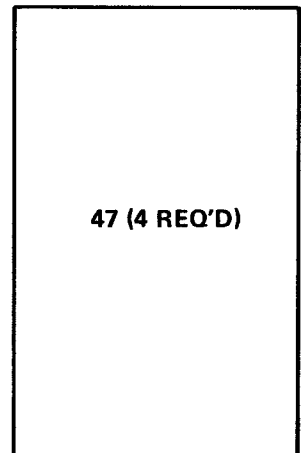

Detail Views

Kit 40048

Step 1

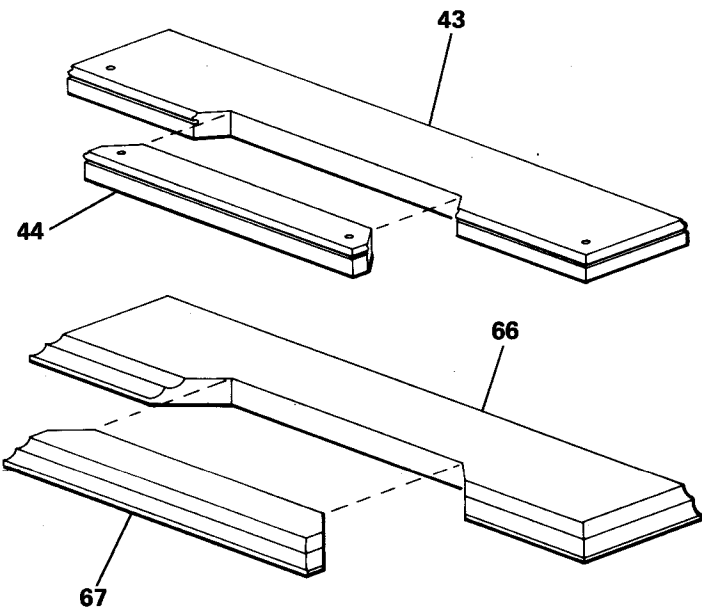

A. Glue the center section of the base (44) to the base (43). Use the center shelf (57) as a guide to check alignment of the hinge pin holes.

B. Glue the center section of the top (67) onto the top (66).

C. Sand surfaces of the top and the base flush.

Step 2

Alignment Pattern

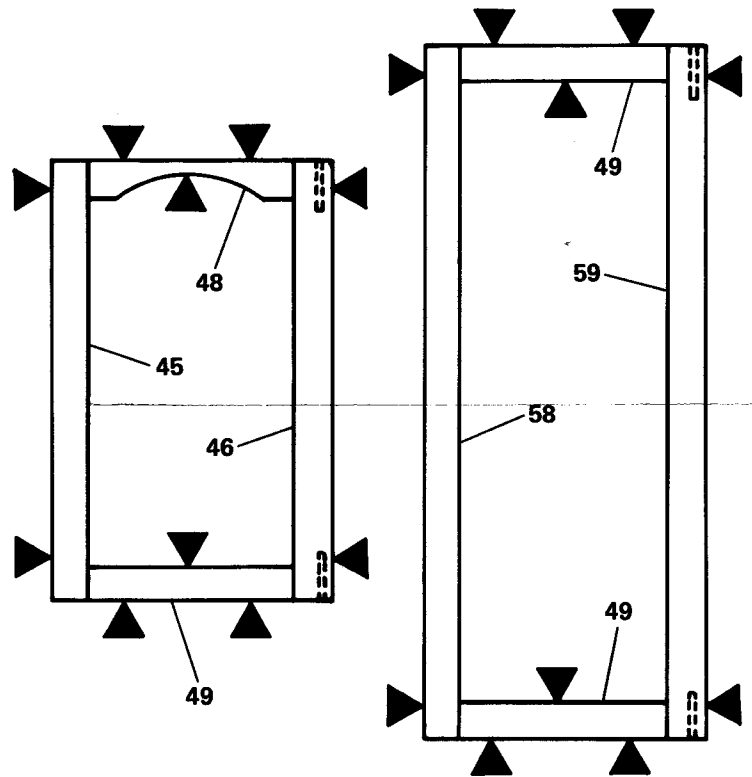

Step 3

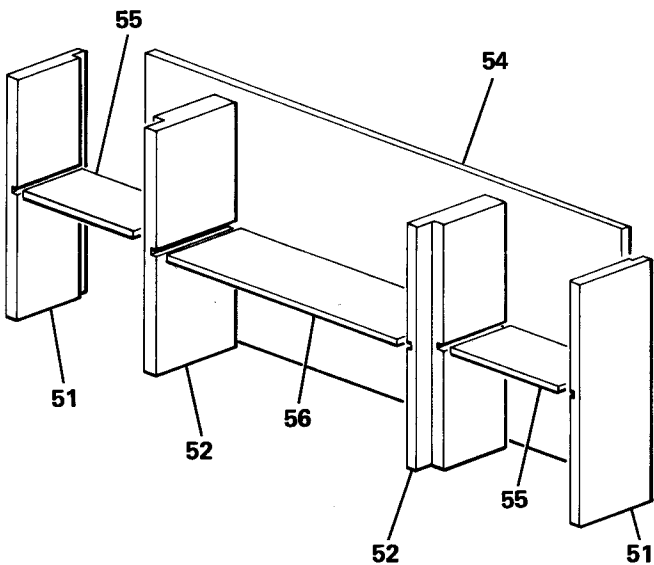

A. Build the bottom case directly on the back (54). Start at one end and glue an end piece (51) to the back (54). Glue shelf (55) into the dado in the end. Then in order, glue the center divider to the back

and shelf (55), shelf (56) into dado of (52), second divider (52) to back and shelf (56), then shelf (55) into (52) and finally the second end (51) to shelf (55) and back (54) square entire assembly.

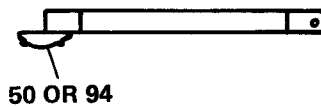
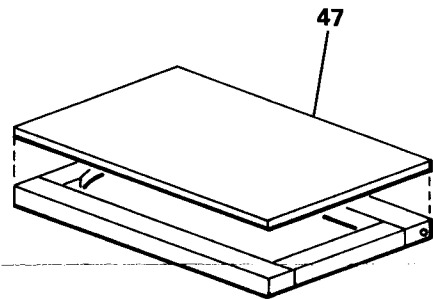

A. Using the Alignment Patterns construct four upper and four lower door frames. The holes for the hinge pins should always be placed nearest the outside edge of the door frame.

B. Apply the back panel (47) on the rear of the bottom door frames. You must watch the

location of the hinge pin holes so that you end up with two left hand doors and two right hand doors.

C. On one center top and bottom door glue center trim (94) or (50) so that it will cover center opening of the doors when they are hung. Apply final finish to doors at this time.

Detail Views

Kit 40048

Step 5

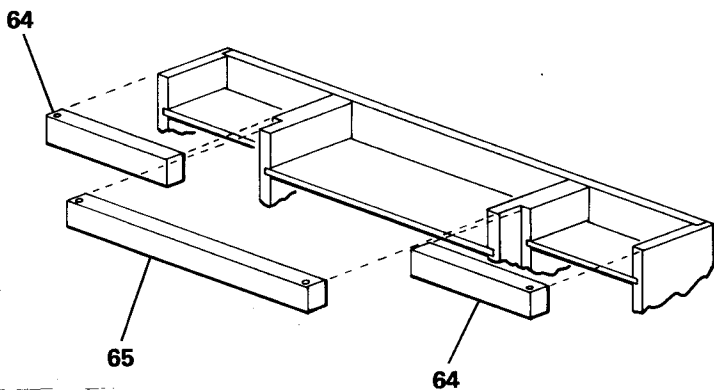

A. Glue the cap blocks (64) & (65) in place. The hinge pin holes in all three blocks are off center and should be installed so the holes are nearest the front edge. The holes in the end blocks (64) should be towards the front and towards the outside.

Step 6

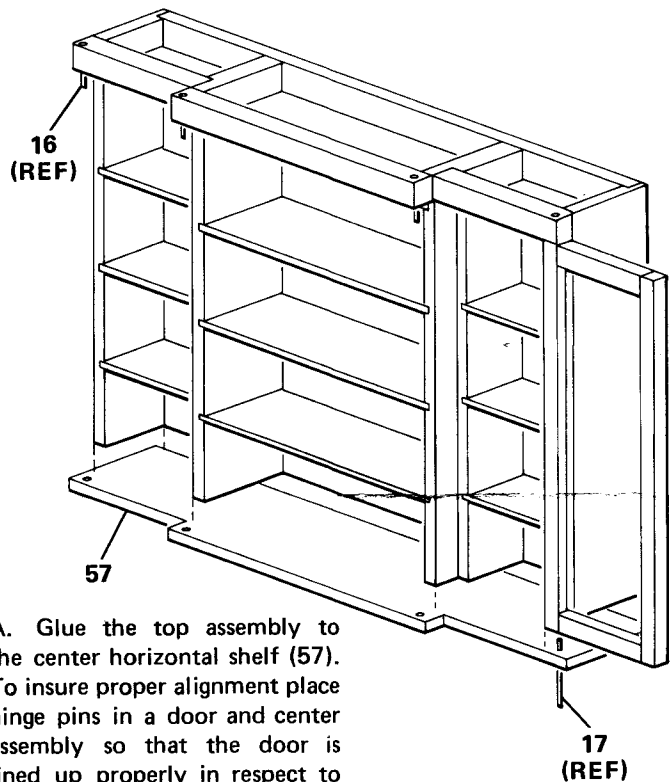

A. Glue the top assembly to the center horizontal shelf (57). To insure proper alignment place hinge pins in a door and center assembly so that the door is lined up properly in respect to the edge of the case. After glue has set remove one pin to remove the door.

Step 7

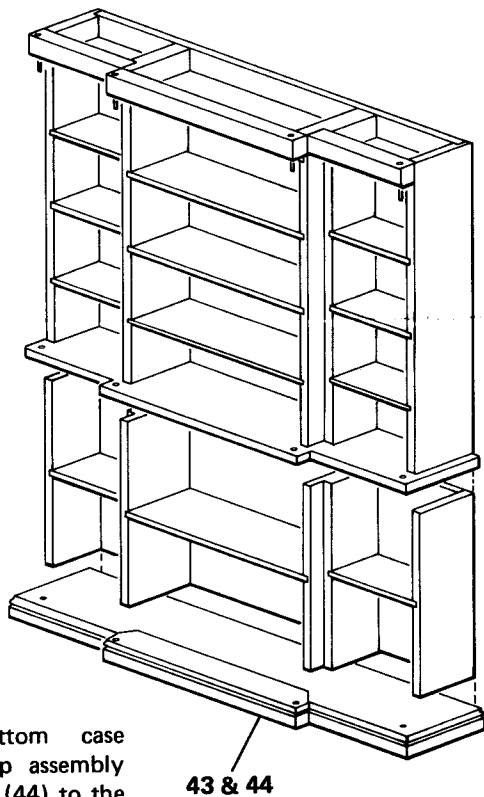

A. Glue the bottom case assembly to the top assembly and the base (43) & (44) to the entire assembly. Use a bottom door to check alignment using the same procedure used in Step 6.

Step 8

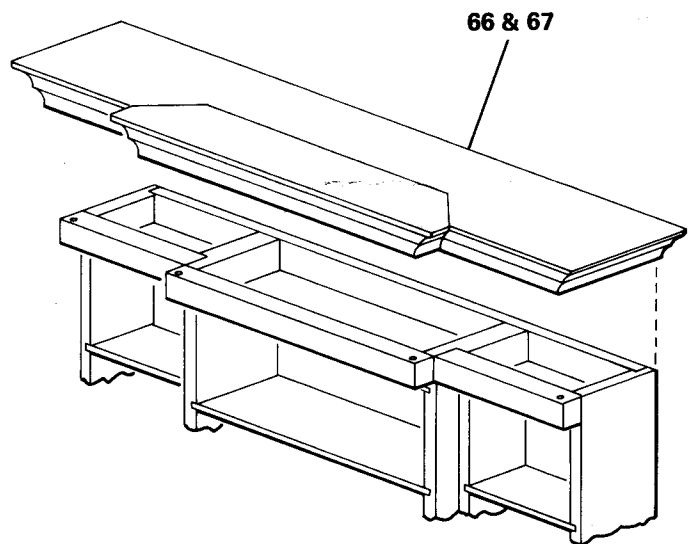

A. Glue the cornice (66) & (67) to the entire case assembly. It should be centered and flush at the back

Detail Views

Kit 40048

Step 9

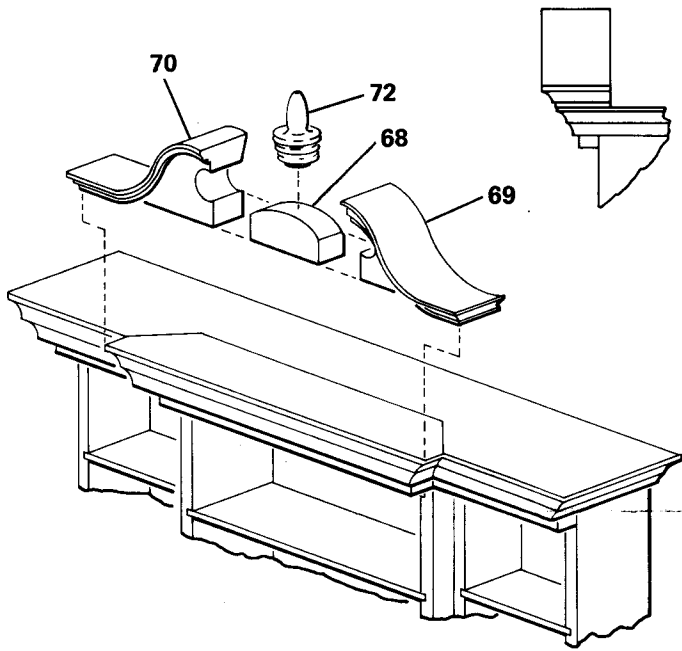

A. Glue the left (70), center (68) and right (69) pediment pieces to the cornice as illustrated. Then glue the finial (72) in place.

B. Case is ready for final finishing.

Step 10

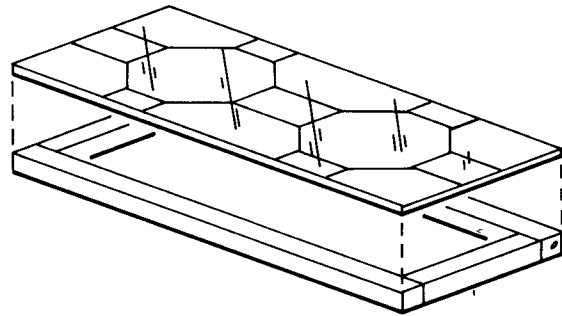

A. After upper doors have received their final finish separate window sheet into four separate panes. Use white glue to attach them to the back of the door frames. Check that hinge pin holes are in the proper direction so that you have two left and two right doors. Check alignment of pane markings in relationship to each other so corresponding lines are aligned.

Step 11

A. Install doors from top to bottom as follows:

Place short pin (16) in top hinge pin hole of top door and insert in hole in cap block.



Place long pin (17) in top hole of bottom door and insert through hole in center shelf into bottom hole of top door.

Insert short pin (16) through hole in base and into bottom hole of bottom door.

B. Glue keyhole plate (18) on doors on side opposite hinge in line with center shelf of each section.

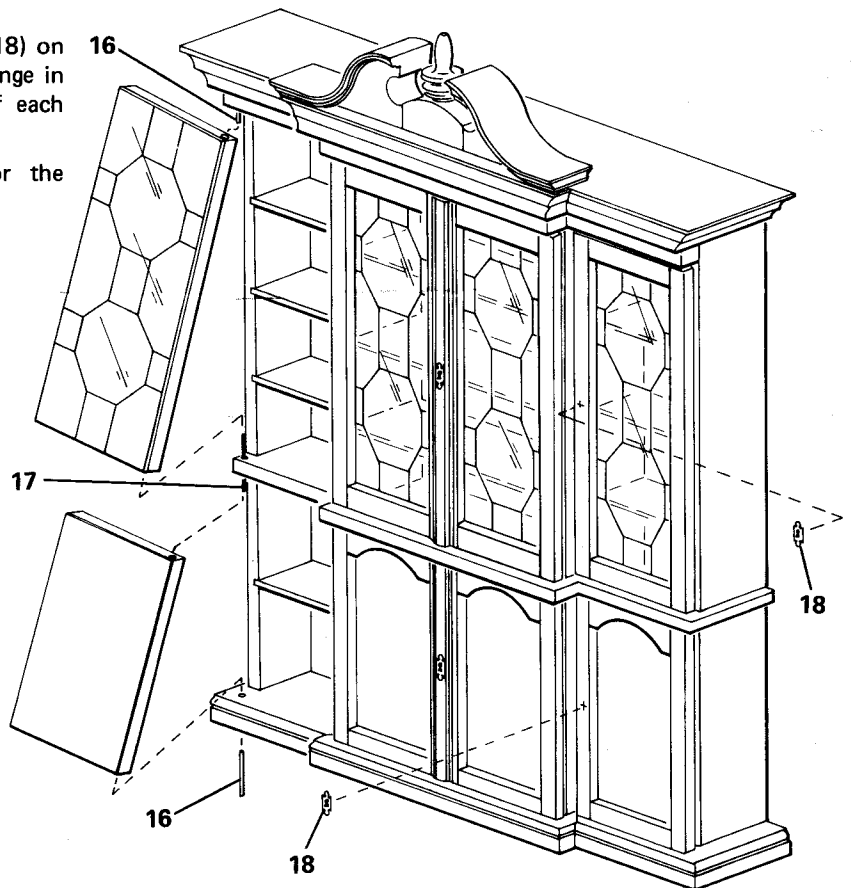
C. Repeat procedure for the other three sets of doors.



HARDWARE CHECKLIST		
DESCRIPTION	VISUAL DESCRIPTION	QTY
HINGE PIN (16)		8
HINGE PIN (17)		4
KEYHOLE PLATE (18)		6