

COLLECTORS NO. 40027



Cabriole Leg
Chippendale Arm Chair
Circa 1760

The Chippendale Arm Chairs were relatively massive yet the smooth curving arms and brackets tended to offset the oversize appearance which was a common trait of his chairs.

Chairs of this type were most commonly found in the dining room but were also utilized in many rooms of the home, at desks, writing tables, or in hallways. The elegance of their rich carving and beautiful upholstery were appreciated wherever they were used.

The arm brackets were usually dovetailed part way into the seat frame. The brackets were then curved to flow smoothly into the arm itself giving the feeling that they were one in the same pieces. Never was there the feeling that the bracket was merely a post supporting the arm. Originally the arm chairs were reserved for the master of the house and prominent guests. Because of this they were usually the most richly carved of all chairs. The knees of the cabriole legs and the top rail received the greatest attention from the carver. Of course the ball-and-claw foot was always in evidence on the Chippendale chairs with cabriole legs. In many of his designs the leg carving was carried over onto the apron around the chair seat.

ASSEMBLY AND FINISHING INSTRUCTIONS



AUTHENTIC REPRODUCTIONS IN MINIATURE

The X-ACTO® House of Miniatures Collectors Series™ of furniture and accessories have all been carefully researched by specialists through major museum and library collections to assure the highest quality of authenticity in reproduction. Details are extraordinarily accurate to satisfy the most discriminating miniaturist.

All wood parts are machined to assure accurate and precise acceptance of each piece by another.

For a complete catalog of the X-ACTO® HOUSE OF MINIATURES furniture line and accessories, write to:

THE HOUSE OF MINIATURES
Customer Service - Catalog Dept.
80 Newbridge Road
Bergenfield, NJ 07621

INTRODUCTION

BEFORE STARTING

Identify and account for each part by placing it on the Layout Sheet (make sure the correct layout sheet is used when working on multi-kit Instruction Sheets). Should any parts be missing, send a post card to:

THE HOUSE OF MINIATURES
Customer Service - Parts Dept.
2000 Craftmark Center
Statesville, NC 28677-2000

Please print Name, Address, Part Number (Number from Layout Sheet) and Kit Name and Number on card when ordering.

SANDING

Before assembly, sand all the outer surfaces of individual parts with 220 grit sandpaper, or finer, sanded in the same direction as the wood grain until the surface is smooth. Take care not to round any edges or corners of the pieces. Finish sanding with 280 grit sandpaper.

PRE-ASSEMBLY

A. After sanding, check the proper location and fit of each part by assembling parts loosely, without gluing. Use the **DETAIL VIEWS** as a guide.

B. All parts for X-ACTO kits are made on precision milling machines. When adjustments are required, sand to fit.

TOOLS AND MATERIALS

A. The following tools will be helpful in constructing this kit:

1. Knife, X-ACTO No. 1, with Blade No. 11
2. Tweezer, X-ACTO No. 7336
3. Two-inch Sander, X-ACTO No. 7042
4. Large Clamp, X-ACTO No. 7004
5. Small Clamp, X-ACTO No. 7003
6. X-ACTO Professional Finishing Kit (or equivalent, see note)

B. The following materials will be needed to construct this kit:

1. X-ACTO Tinted Glue (see note)
2. Waxed paper
3. Sandpaper - 220 and 400 grit
4. Steel Wool - Grade 0000
5. White glue (or equivalent)
6. Small Artist's Brush

NOTE: The X-ACTO tinted glue is matched to the finish used in the Professional Finishing Kit. This will produce the authentic finish of the period in which the original Furniture was produced. When not using X-ACTO glue follow manufacturer's directions.

GLUING

A. Glue should be applied in small amounts to surface being joined. When gluing dado joints apply glue to dado only.

B. To ensure a tight fit, squeeze excess glue out of the joints. Hold glued parts together with clamps, rubber bands or weights on the parts.

C. Wipe off excess glue promptly.

D. Be sure a glued assembly has dried thoroughly before adding parts.

FINISHING

The X-ACTO Professional Finishing Kit enables you to finish your furniture by the same process used by the professional furniture maker. The end result is what is important — there are easier methods, but none that will give the quality results that this process will. If you use a finish other than X-ACTO's, refer to the manufacturer's directions.

Detail Views

KIT 40027

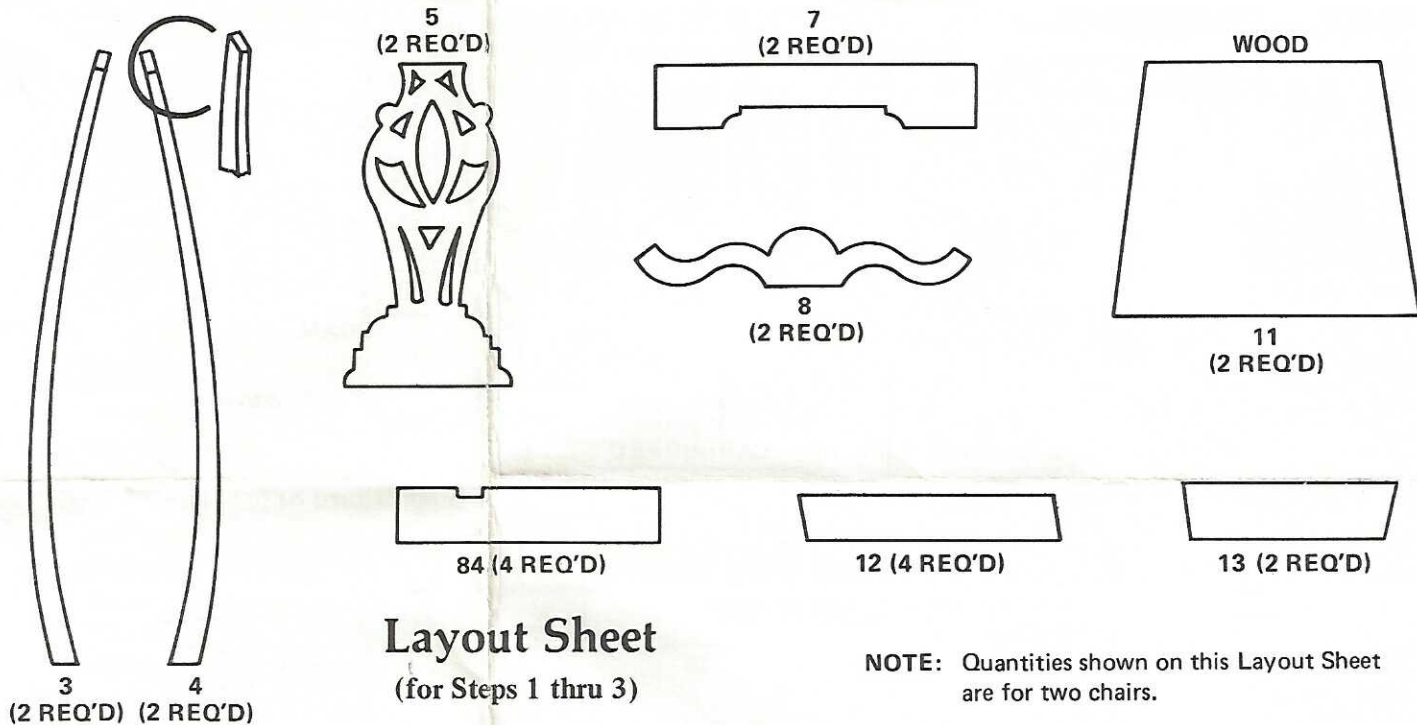

Layout Sheet

(for Steps 1 thru 3)

NOTE: Quantities shown on this Layout Sheet are for two chairs.

Step 1

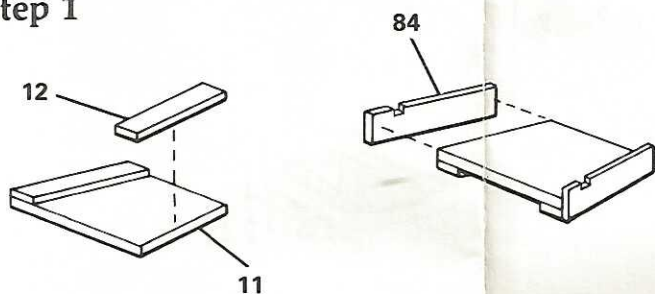

A. Glue bottom braces 12 to seat bottom (11).

B. Turn assembly over and glue seat sides (84) to seat bottom keeping front, rear and bottom edges flush.

Step 2

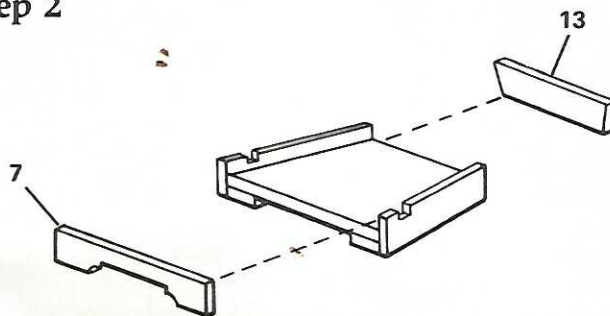

A. Glue seat front (7) to seat bottom keeping bottom and side edges flush.

B. Center and glue seat back (13) to seat bottom keeping bottom edges flush.

NOTE: Notches formed at rear corners are to accommodate rear legs.

Step 3

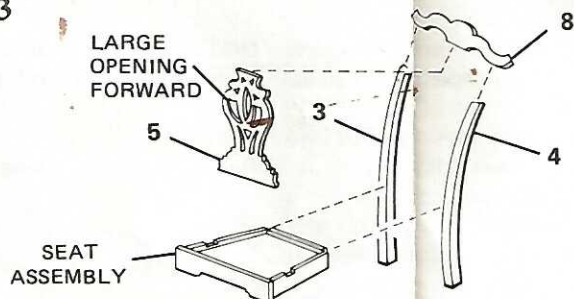

A. Utilizing Alignment Pattern No. 1, glue top rail (8) to left rear leg (4) and right rear leg (3).

B. Trim top and bottom edges of splat flush.

NOTE: Use alignment guide (18) for proper angle of seat assembly. Use splat (5) to determine location of seat.

C. Glue splat (5) to top rail (8) and seat assembly.

Detail Views

KIT 40027

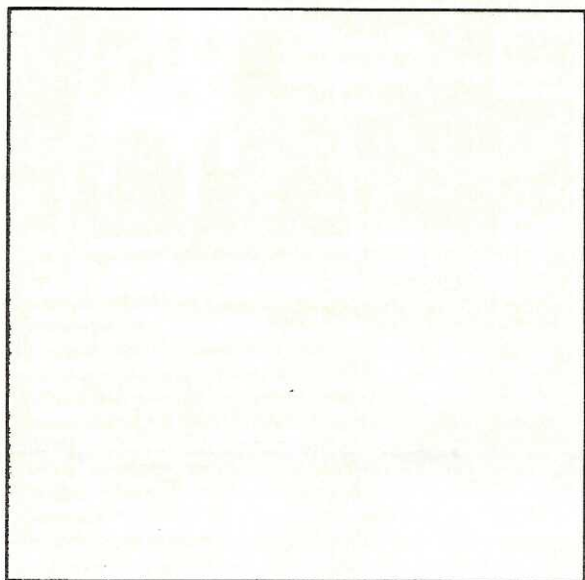

15
(MATERIAL)
(2 REQ'D)

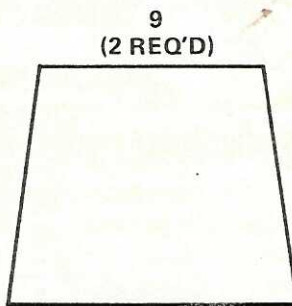

9
(2 REQ'D)
CARDBOARD

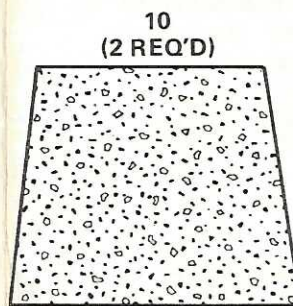

10
(2 REQ'D)
FOAM



6 (4 REQ'D)

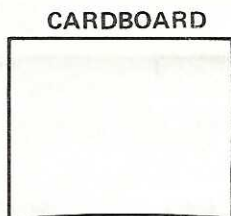

18

Layout Sheet

(for Steps 4 thru 8)



50 (4 REQ'D)

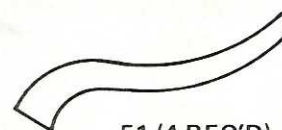

51 (4 REQ'D)

Step 4

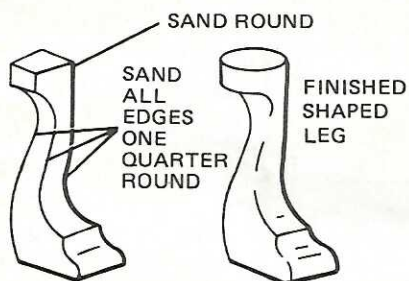

NOTE: Cabriole legs may be shaped prior to sanding.

A. Shape legs by sanding the edges.

B. Sand base of legs until they are round.

Step 5

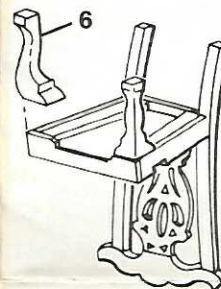

A. Glue legs (6) to front corners of seat assembly.

Step 6

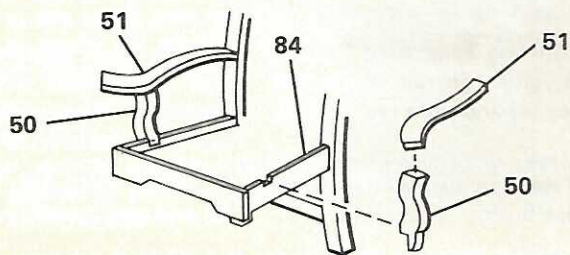

NOTE: Ensure arm supports (50) are perpendicular to sides.

A. Glue arm supports (50) into notches on seat sides (84).

B. Glue arm (51) to arm support (50) and rear legs (3) and (4).

NOTE: Ensure arms are aligned with each other and the chair side rails.

Refer to Final Finishing.

Detail Views

KIT 40027

Step 7

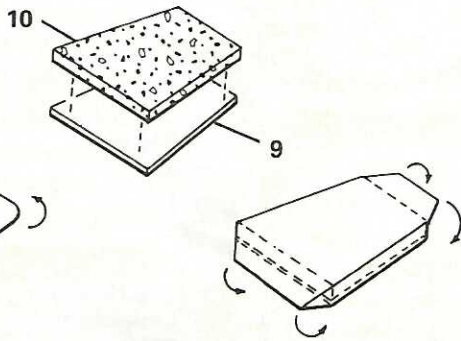

A. Glue cushion (10) to base (9) with white glue.

B. Place cushion (10) down on material (15). Fold material over and glue in place.

C. Tuck each corner under.
D. Fold front and rear of fabric and glue in place.

Step 8

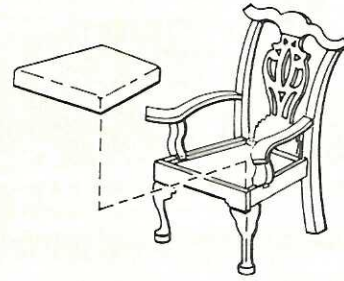

A. After Final Finishing glue cushion to seat.

Alignment Patterns

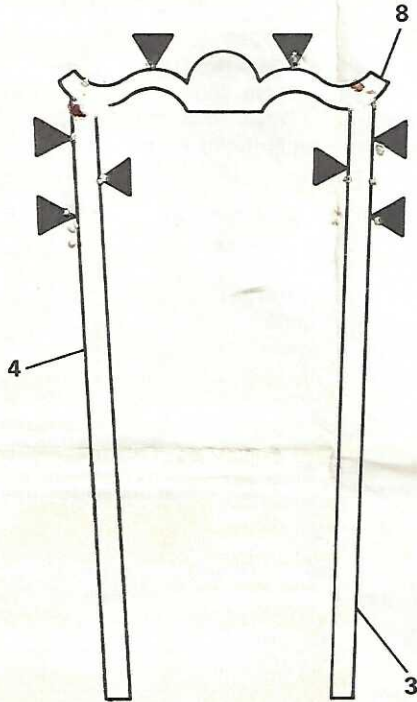

PATTERN NO. 1

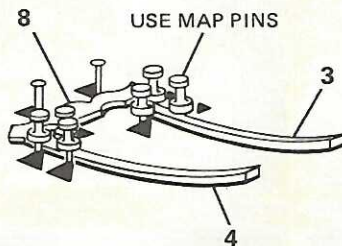

USE MAP PINS

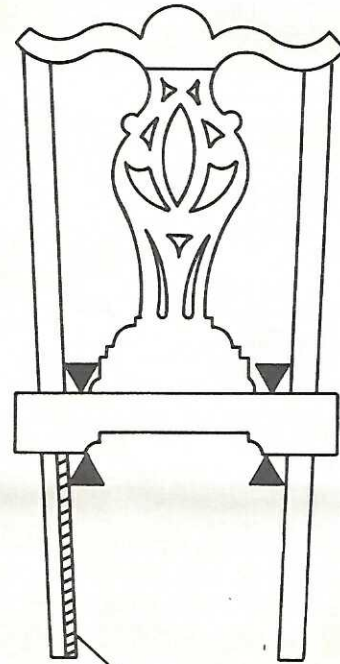

ALIGNMENT GUIDE NO. 18

PATTERN NO. 3

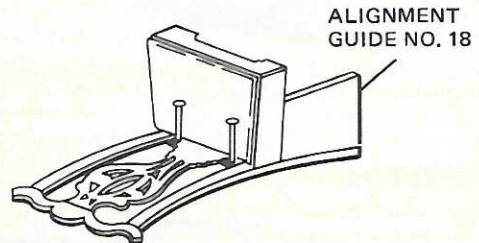

ALIGNMENT GUIDE NO. 18