

COLLECTORS NO. 40025



Chippendale
Sideboard
Circa 1725-50

The sideboard was a popular and useful piece of furniture in the homes of the 18th Century. It was equally at home in the dining room, or in the hallway.

In the dining room the individual drawer locks often protected the family's heirloom silver. In the larger formal entrance halls it was often the depository for visitor's calling cards.

The majority of Chippendale's sideboards were made without drawers, but several designs did incorporate three to four drawers. The design we have copied is typical of the adaption of Chippendale's designs by the American cabinet makers in the 1700's.

Chippendale's designs for this style of furniture varied greatly to suit the taste of his client. The front legs were ornately carved cabriole legs, while the rear legs either matched the front ones or were unadorned and straight. When drawers were used the front treatment was similar to that of the lowboy, and when the drawers were not used the apron was wide and richly carved.

Chippendale worked almost exclusively in mahogany, but copies of his work produced in the Colonies were made in a variety of woods.

In New England, cherry wood was widely used and, due to the popularity, and desirability, of mahogany, it was often called "New England Mahogany."

ASSEMBLY AND FINISHING INSTRUCTIONS



AUTHENTIC REPRODUCTIONS IN MINIATURE

The X-ACTO® HOUSE OF MINIATURES COLLECTORS SERIES of furniture and accessories have all been carefully researched by specialists through major museum and library collections to assure the highest quality of authenticity in reproduction. Details are extraordinarily accurate to satisfy the most discriminating miniaturist.

All wood parts are machined to assure accurate and precise acceptance of each piece by another.

For a complete catalog of the X-ACTO® HOUSE OF MINIATURES furniture line and accessories, write to:
THE HOUSE OF MINIATURES
Customer Service - Catalog Dept.
80 Newbridge Road
Bergenfield, NJ 07621

milling machines. When adjustments are required, sand to fit.

TOOLS AND MATERIALS

A. The following tools will be helpful in constructing this kit:

1. 2" Sander, X-ACTO No. 7042
2. Large Clamp, X-ACTO No. 7004
3. Small Clamp, X-ACTO No. 7003
4. Pin Vise, X-ACTO No. 7144
5. X-ACTO Professional Finishing Kit (or equivalent, see note)

B. The following materials will be needed to construct this kit:

1. X-ACTO Tinted Glue (see note)
2. Sandpaper - 220 and 280 grit
3. Small Artist's Brush

NOTE: The X-ACTO tinted glue is matched to the finish used in the Professional Finishing Kit. This will produce the authentic finish of the period in which the original Furniture was produced. When not using X-ACTO glue follow manufacturer's directions.

GLUING

A. Glue should be applied in small amounts to surface being joined. When gluing dado joints apply glue to **dado only**.

B. To ensure a tight fit, squeeze excess glue out of the joints. Hold glued parts together with clamps, rubber bands or weights on the parts.

C. Wipe off excess glue promptly.

D. Be sure a glued assembly has dried thoroughly before adding parts.

FINISHING

The X-ACTO Professional Finishing Kit enables you to finish your furniture by the same process used by the professional furniture maker. The end result is what is important — there are easier methods, but none that will give the quality results that this process will. If you use a finish other than X-ACTO's, refer to the manufacturer's directions.

INTRODUCTION

BEFORE STARTING

Identify and account for each part by placing it on the Layout Sheet (make sure the correct layout sheet is used when working on multi-kit Instruction Sheets). Should any parts be missing, send a post card to:

THE HOUSE OF MINIATURES
Customer Service - Parts Dept.
2000 Craftmark Center
Statesville, NC 28677-2000

Please print Name, Address, Part Number (Number from Layout Sheet) and Kit Name and Number on card when ordering.

SANDING

Before assembly, sand all the outer surfaces of individual parts with 220 grit sandpaper, or finer, sanded in the same direction as the wood grain until the surface is smooth. Take care not to round any edges or corners of the pieces. Finish sanding with 280 grit sandpaper.

PRE-ASSEMBLY

A. After sanding, check the proper location and fit of each part by assembling parts loosely, without gluing. Use the **DETAIL VIEWS** as a guide.

B. All parts for X-ACTO kits are made on precision

Layout Sheet

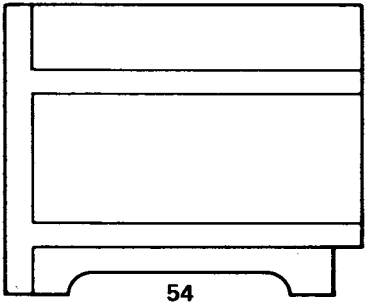

54

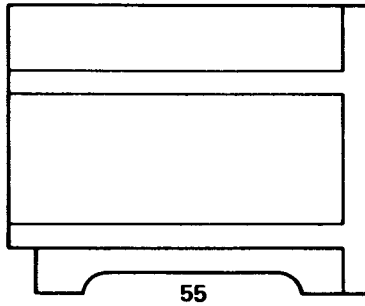

55

96

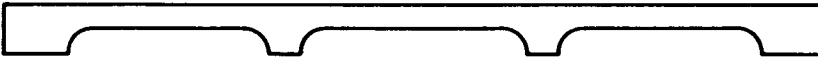

58
(2 REQ'D)

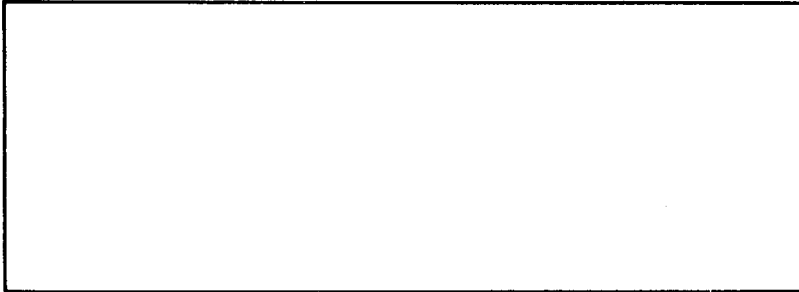

97

8
(2 REQ'D)

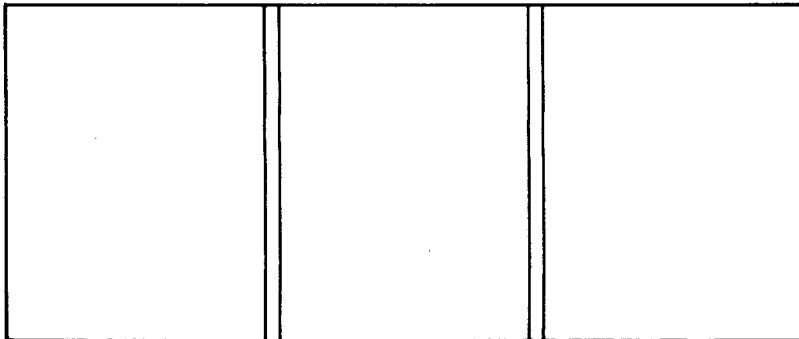

98
(2 REQ'D)

6
(4 REQ'D)



71
(3 REQ'D)



83
(2 REQ'D)



87
(6 REQ'D)

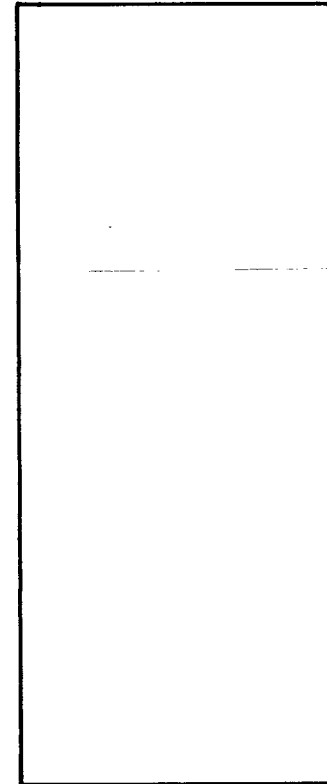

0



99

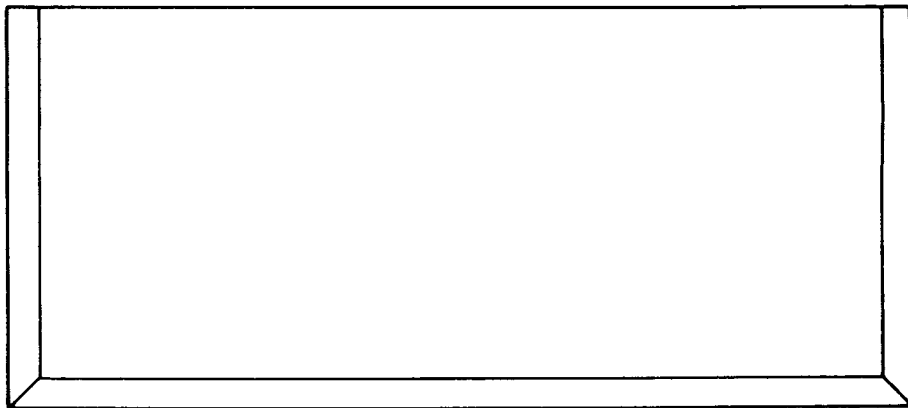

2

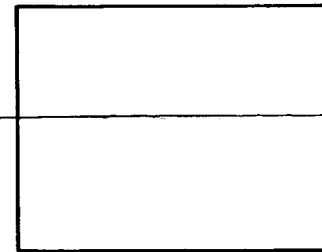

21
(3 REQ'D)

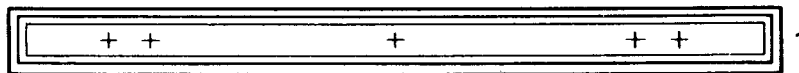

1

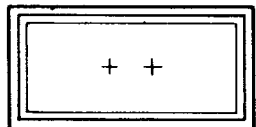



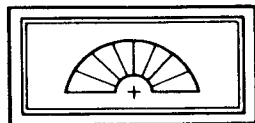

9
(2 REQ'D)



22

HARDWARE CHECK LIST

DESCRIPTION	VISUAL IDENTIFICATION	QTY
Knob		1
Escutcheon		4
Bail		4
Escutcheon		1
Key Plate		1

Detail Views

KIT 40025

Step 1

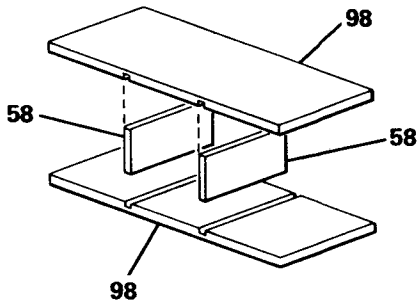

NOTE: Make certain that parts (98) and (58) are flush at front edge.

A. Glue vertical drawer dividers (58) into dadoes in horizontal drawer dividers (98).

Step 4

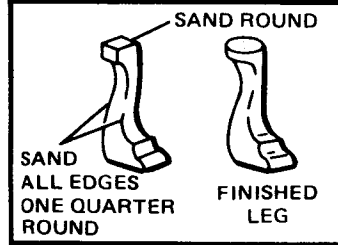
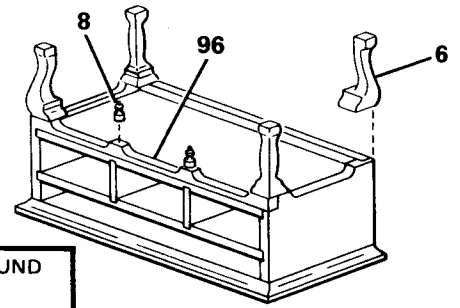

NOTE: Legs may be shaped prior to assembly, by sanding as shown.

NOTE: Turn assembly upside down.

A. Center and glue finials (8) to projections on front base (96).
 B. Glue legs (6) to assembly keeping outer edges flush with the assembly.

Step 2

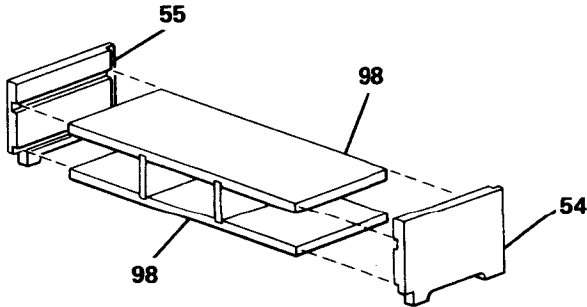

NOTE: Make certain parts (54) and (55) are flush with front edge of horizontal dividers (98).

A. Glue horizontal dividers (54) and (55) into dadoes of parts (54) and (55).

Step 5

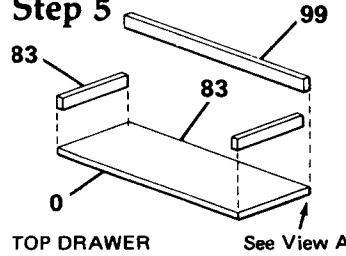

TOP DRAWER See View A

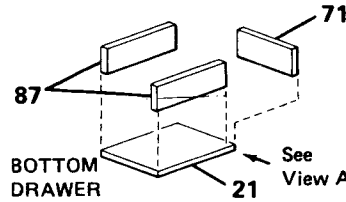

BOTTOM DRAWER See View A

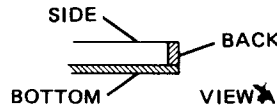

NOTE: Use white glue for assembly of drawers, if inside is not going to be stained.

A. Mark position of escutcheons on drawer fronts (1), (9) and (22) with pin using layout sheet as a guide.

B. Drill through holes as marked using a 65 drill bit.

NOTE: Refer to Final Finishing for assembly and drawer fronts.

C. Glue sides to bottom making certain they are flush with front edges.

D. Glue back to bottom and against rear edge of sides.

Step 3

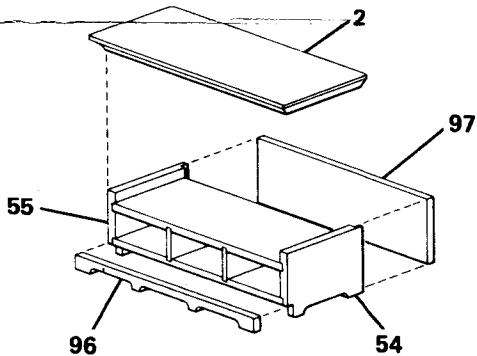

NOTE: Make certain back (97) is flush with top and bottom edges of parts (54) and (55). All parts must be square.

A. Glue back (97) into rabbets on side pieces (54) and (55).

B. Glue top (89) to top edges of parts (54), (55) and (56). Center with back flush.

C. Glue base front (96) to notches in parts (54) and (55).

Step 6

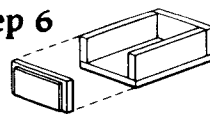

NOTE: Drawer fronts and hardware are installed after all Final Finishing steps are complete.

A. Glue front of each drawer to front edges of sides and bottom.

B. (Top Drawer only) apply a small amount of white glue to the back on key plate and glue to center of drawer front.

C. (Top and 2 Side Drawers) Pass handle through escutcheon and apply a small amount of white glue to back of plate.

ESCUTCHEON

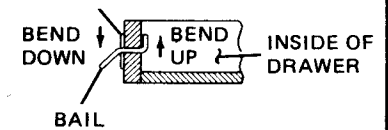

CROSS-SECTION OF TOP AND 3 BOTTOM DRAWERS

D. Install bail through holes in drawer front.

E. Bend up protruding ends and bend down front of handle.

F. Lower (Middle Drawer only) apply a small amount of glue to round escutcheon and glue to drawer front. Insert knob (brad).

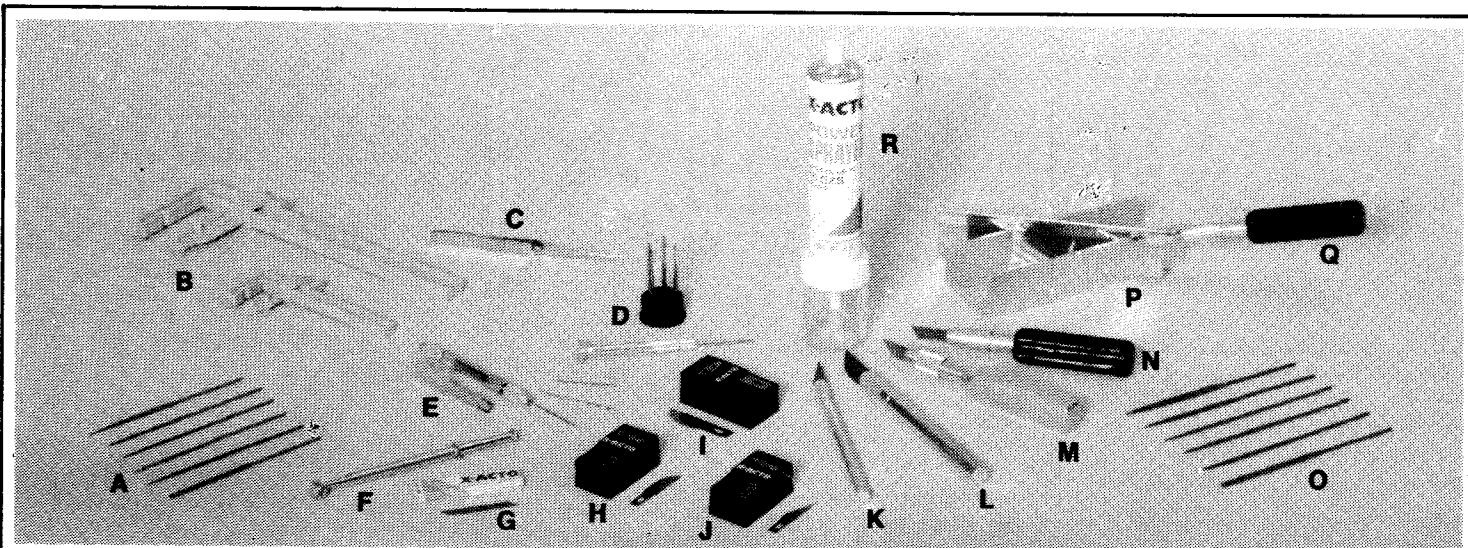

A. MINIATURE FILE SET

6 miniature needle files. 3 1/8" long. For intricate filing. Vinyl storage pouch. No. 7365

B. PLASTIC CLAMPS

Light duty plastic clamps for delicate work. Notched jaw allows grip of round parts. Smooth face prevents damage to workpiece.

Small plastic clamp. 3/4" opening with 1" throat depth.

2 per card: No. 7003

Large plastic clamp. 7/16" opening with 2 1/16" throat depth.

2 per card: No. 7004

C. SELF-CLOSING POINTED TWEEZER

Self-closing serrated points. Nickel-plated steel. 6 1/2."

Carded: No. 7337

D. SCREWDRIVER WITH INTERCHANGEABLE BLADES

Aluminum handle and chuck and 5 steel screwdriver blades sizes .040" through .100." Notched shank for greater torque. Storage base.

Carded: No. 7070

E. PIN VISE SET

Includes double-ended pin vise, vise bit guard and 3 assorted drill bits.

Carded: No. 7144

F. PARTPICKER

For small hard-to-handle pieces. Smooth one-handed action.

Carded: No. 7380

G. No. 13 BLADE

Precision saw cutting. 5 blades. Carded: No. 213

H. No. 10 BLADE

For fine general cutting, carving, correcting stencils.

Safety dispenser of 10 blades. Carded: No. 410

I. No. 22 BLADE

General shaping, whittling, trimming, removing excess flashing. Safety dispenser of 10 blade. Carded: No. 422

J. No. 11 BLADE

Extremely sharp point for fine angle cutting and stripping.

Safety dispenser of 10 blades. Carded: No. 411

K. No. 1 KNIFE

Aluminum handle 4 1/8" long with No. 11 blade. Carded: No. 3201

L. No. 2 KNIFE

Aluminum handle 5" long with No. 22 blade. Carded: No. 3202

M. No. 6 KNIFE

Aluminum handle 4 3/4" long with No. 24 blade. Carded: No. 3206

N. No. 5 KNIFE

Plastic handle with metal blade lock, 4 1/4" long with No. 19 blade.

Carded: No. 3205

O. MINIATURE NEEDLE RASPS

6 assorted rasps. For rough shaping of wood or plastic.

4 3/4" long. Vinyl storage pouch. No. 7366

P. MITRE BOX

Aluminum 3/4" x 1 3/4" capacity. 6" long. With two 45° and one 90° cutting slots. Carded: No. 7533

Q. EXTRA-FINE RAZOR SAW

1 1/4" deep with cutting edge 5 1/2" long and 54 teeth per inch for extra fine precision. For use with No. 7533 mitre box. Carded: No. 7535

R. POWER SPRAYER

Push-button action sprays evenly. Includes a one ounce jar and propellant to spray on intricate or flat surfaces up to 16 ounces of liquid materials. Carded: No. 43561

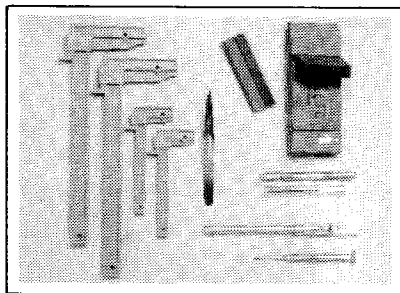

MINIATURIST'S TOOL SET

Basic tools for assembling miniatures, models and working with small parts. 4 clamps, tweezers, pin vise with 3 bits, 2 sanders, screwdriver and No. 1 Knife in fitted tray. No. 43910

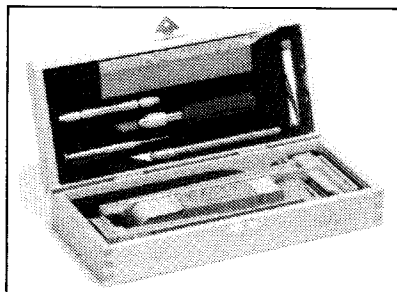

DELUXE MINIATURIST'S TOOL CHEST

Fitted wooden chest contains precision tools for assembling miniatures, models and working with small parts: razor saw blade, mitre box, 4 clamps, pin vise and 3 bits, Nos. 1 and 5 Knives, sanders and screwdriver. Boxed: No. 43911