

COLLECTORS NO. 40020  
TIDEWATER VIRGINIA  
FIREPLACE

ASSEMBLY AND  
FINISHING INSTRUCTIONS



AUTHENTIC REPRODUCTIONS IN MINIATURE



The X-ACTO® House of Miniatures® Collectors Series of furniture and accessories have all been carefully researched by specialists through major museum and library collections to assure the highest quality of authenticity in reproduction. Details are extraordinarily accurate to satisfy the most discriminating miniaturist.

Every item in the line is an authentic reproduction in miniature of regular-size furniture created by master craftsmen during the Colonial period, precision scaled, one inch to one foot.

All wood parts are machined to assure accurate and precise acceptance of each piece by another.

The rooms illustrated have been completed using standard X-ACTO® HOUSE OF MINIATURES products. All individual components are available.



For a complete catalog of the X-ACTO® HOUSE OF MINIATURES furniture line and accessories, write to:

X-ACTO® THE HOUSE OF  
MINIATURES Dept. KIT  
45-35 Van Dam Street  
Long Island City, New York  
11101

Please include 50¢ for postage and handling.

# INTRODUCTION

## INSTRUCTIONS BEFORE STARTING

### before starting

A. Identify and account for each part by placing it on the **LAYOUT SHEET** (Page 2). This will indicate, at a glance, whether any parts are missing. **(See instructions at bottom of last sheet to order missing parts.)**

B. The LAYOUT SHEET contains a molding configuration list. Use this to identify the different molding that comes with the kit.

### sanding

**NOTE:** When using sandpaper, remember that the higher the grit number, the finer the finish.

A. One sanding method that has proved successful is the use of a sanding platform. Tape a sheet of sandpaper of the proper grit size to a hard flat surface such as a table top or wood block. Press down **lightly** and move the piece to be sanded **in the same direction** as the wood grain until the surface is smooth. **Take care not to round any edges or corners of the pieces.**

### gluing

A. Glue should be applied in small amounts to both surfaces being joined. On end cuts, it may be necessary to apply a second coat of glue before joining the parts.

B. To ensure a tight fit, squeeze excess glue out of the joints by holding glued parts together with either clamps, rubber bands or by placing weights on the parts.

C. Wipe off excess glue promptly with a damp cloth.

D. Be sure a glued assembly has dried thoroughly before adding any more parts.





### tools and materials

A. The following tools **will be helpful** in constructing this kit:

1. Knife, X-ACTO No. 1, with Blade, X-ACTO No. 11
2. Tweezer, X-ACTO No. 36
3. Two-inch Sander, X-ACTO No. 42
4. Large Clamp, X-ACTO No. 4004
5. Small Clamp, X-ACTO No. 4003
6. Power Sprayer, X-ACTO No. 43561
7. Mitre Box, X-ACTO No. 533
8. Razor Saw Set, X-ACTO No. 4055C

B. The following materials **will be needed** to construct this kit:

1. Straight pins or artist's push pins
2. Rubber bands
3. Waxed paper
4. Sandpaper - 220
5. Ruler
6. Paint of your choice
7. White glue, or any good wood glue
8. Small artist's brush

MOLDING CONFIGURATION LIST			
PART NO. 91	PART NO. 92	PART NO. 93	PART NO. 94
QTY 2	QTY 2	QTY 2	QTY 1
			

**Inside** molding dimensions are given from furthest point to furthest point and shall be cut at 45° angles unless otherwise noted.

**Outside** molding dimensions are given from inside point to inside point and shall be cut at 45° angles unless otherwise noted.

**Mitre Cut:** To match two pieces of molding together by cutting the two pieces at a specified angle.

**Straight Cut:** To match two pieces together without the use of a mitered cut.

Example:

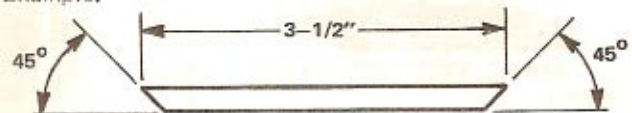

Example:

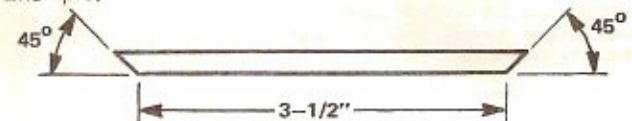

Example:

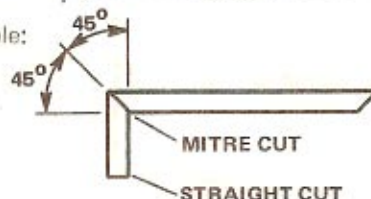

# LAYOUT SHEET

76  
REQ'D)

78 (2 REQ'D)

79

83 (4 REQ'D)

82  
(2 REQ'D)

84

85

86

89

90 (2 REQ'D)

88 (2 REQ'D)

SIDE  
VIEW  
OF P/  
88

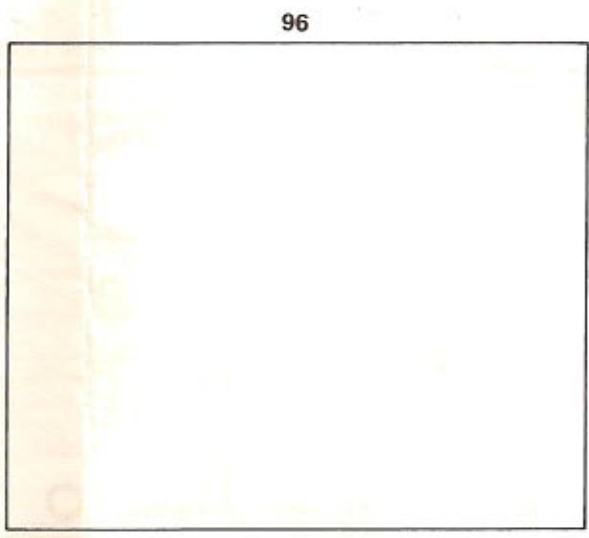
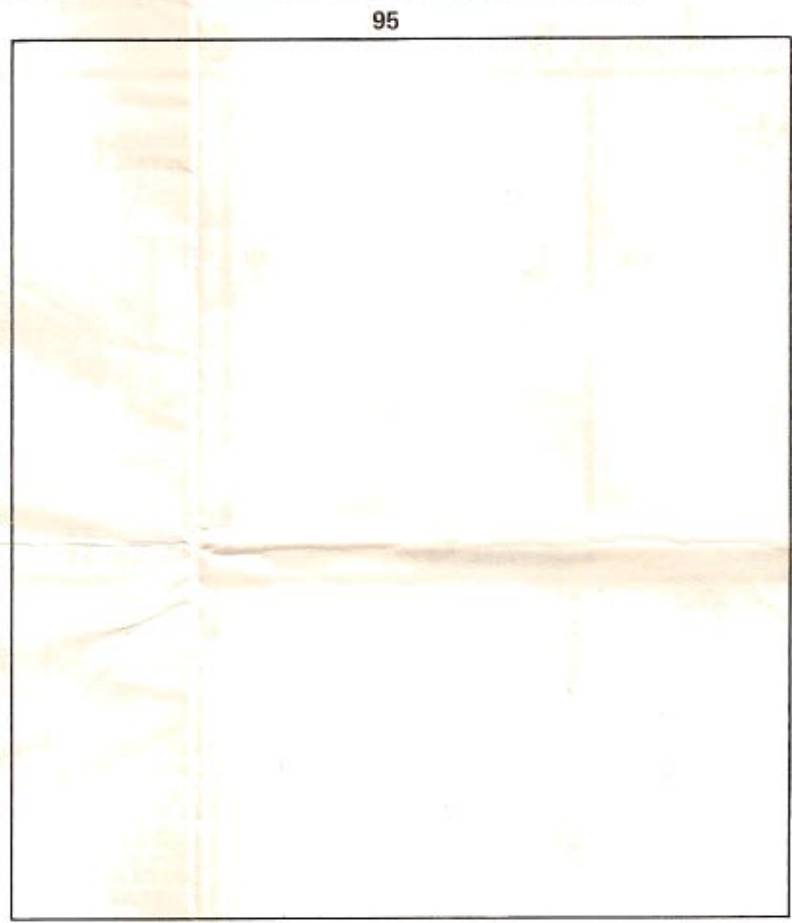
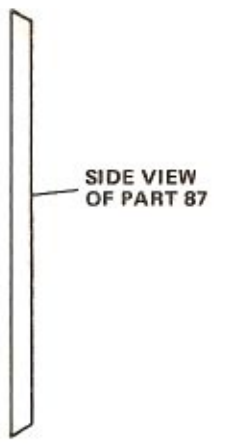
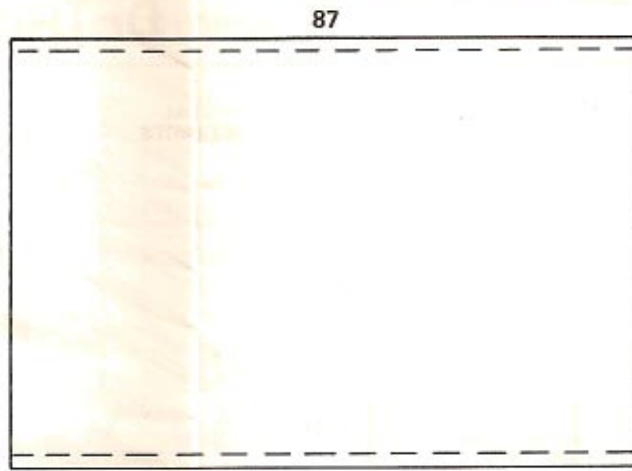
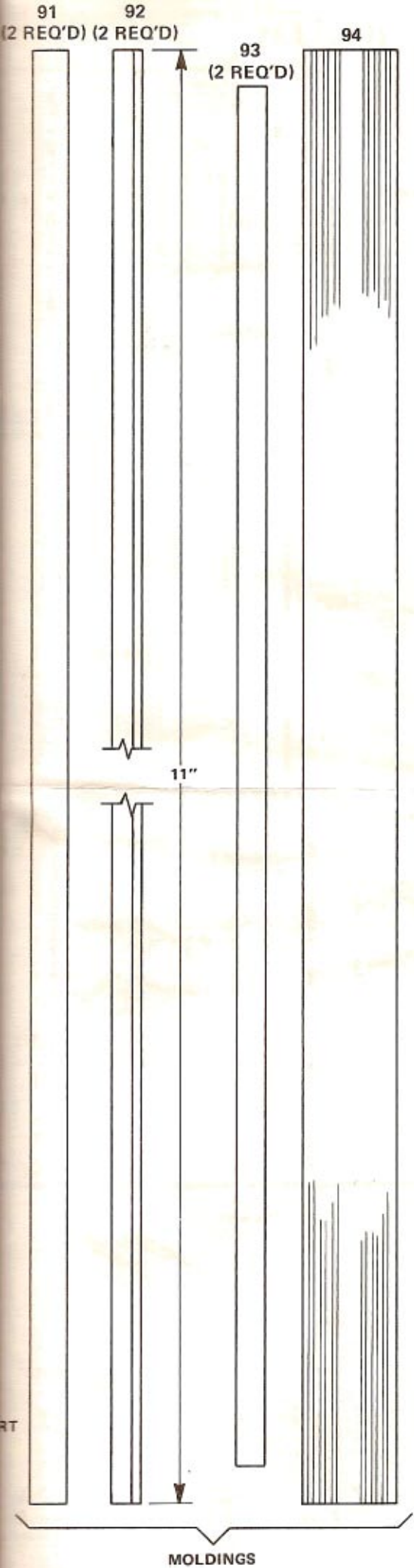

# DETAIL VIEWS

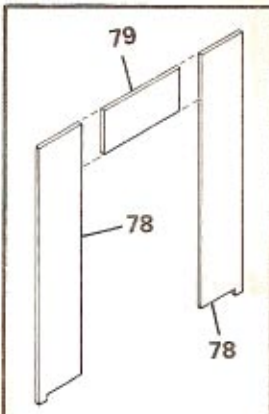

DETAIL A

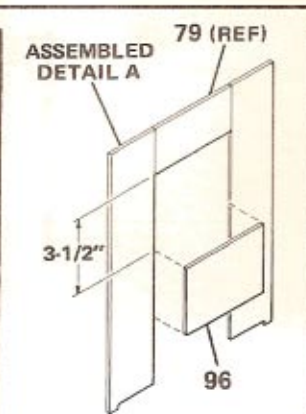

DETAIL B

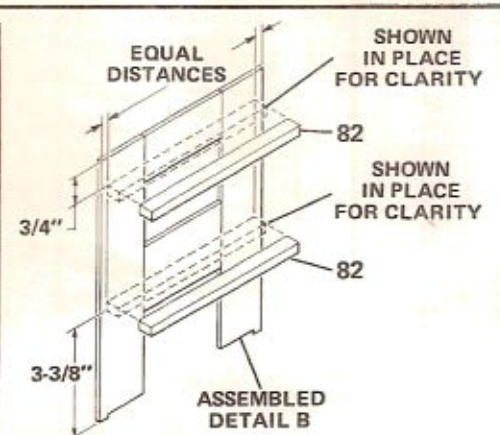

DETAIL C

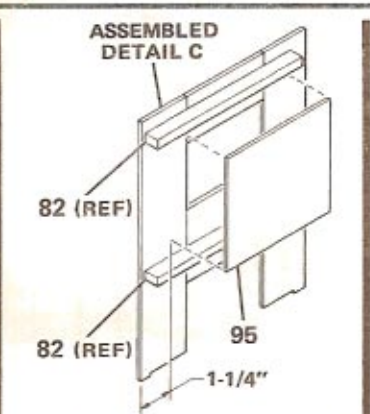

DETAIL D

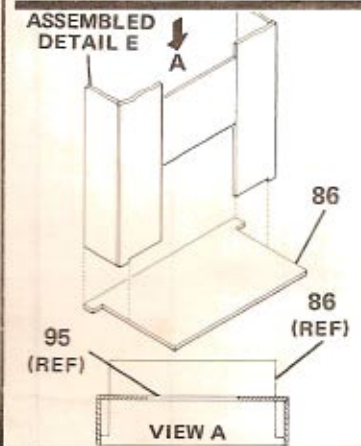

DETAIL E

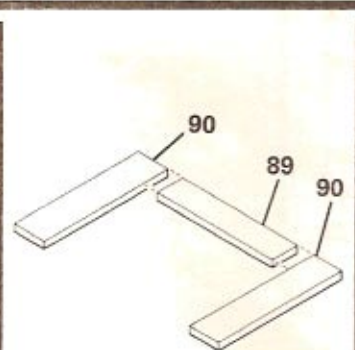

DETAIL F

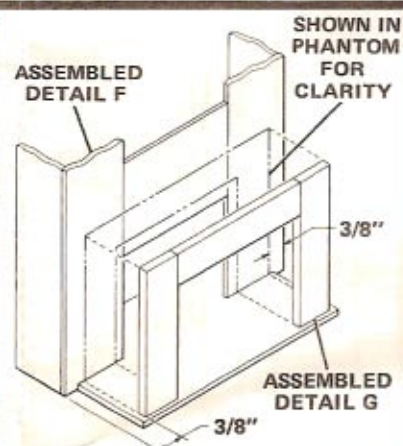

DETAIL G

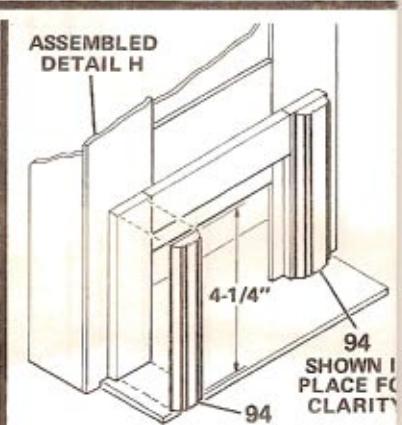

DETAIL H

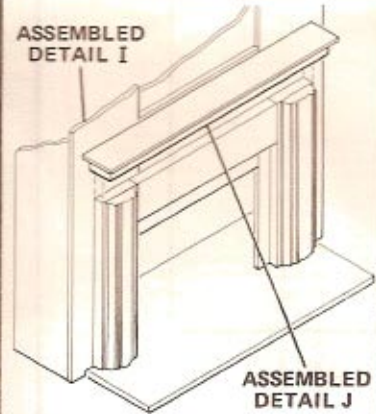

DETAIL I

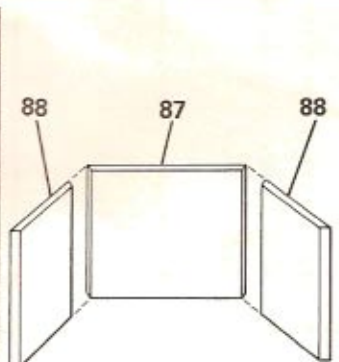

DETAIL J

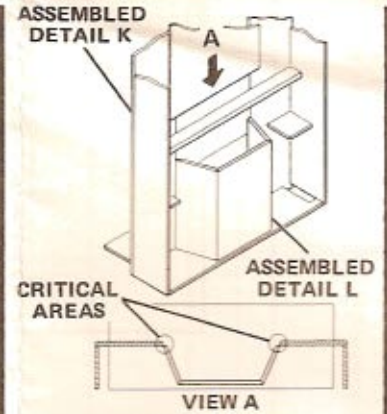

DETAIL K

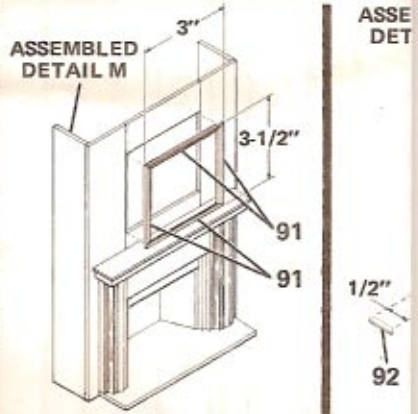

DETAIL L

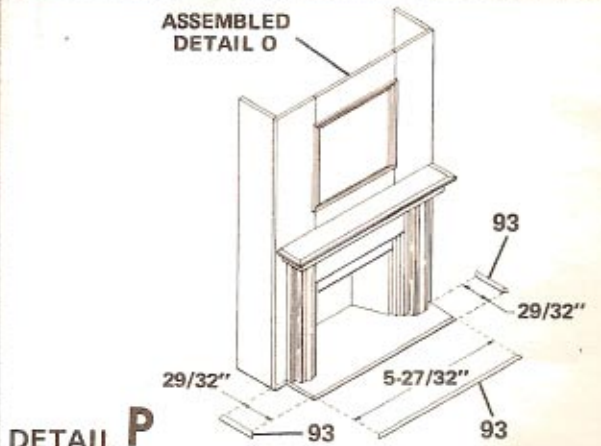

DETAIL M

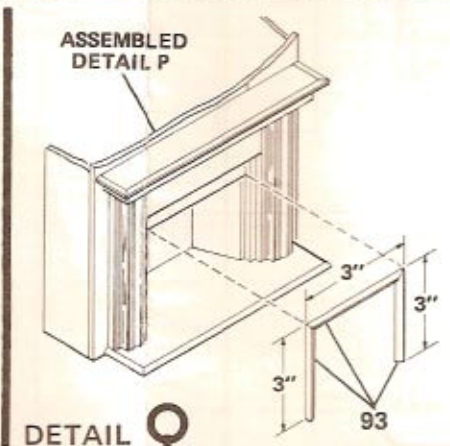

DETAIL N

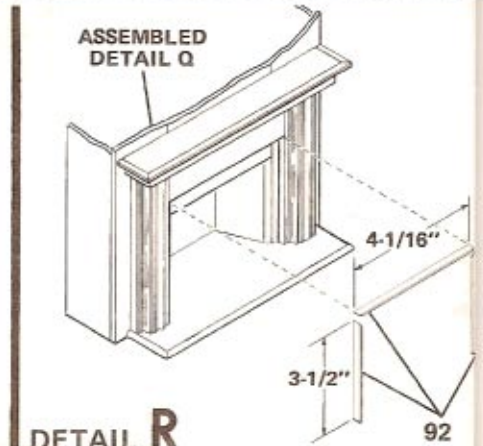

DETAIL O

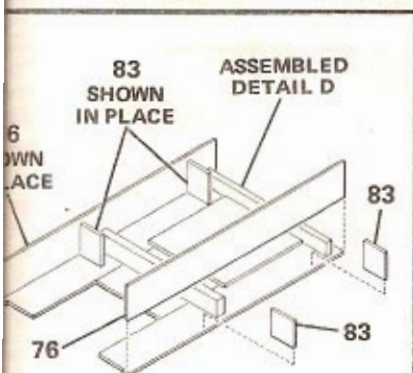

DETAIL E

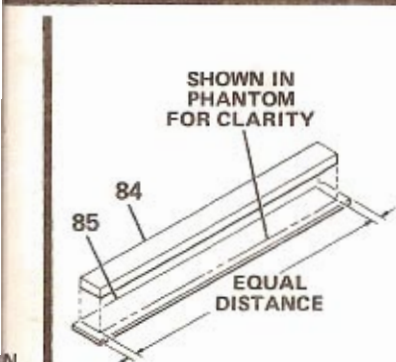

DETAIL F

DETAIL J

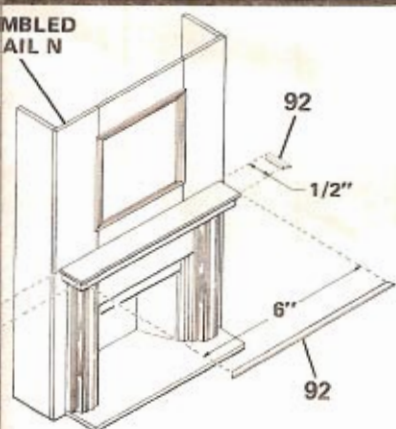

DETAIL O

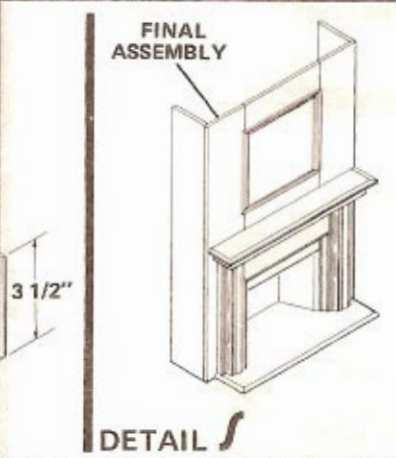

A. Before starting to assemble your kit, study all illustrations and instructions carefully. Be certain you understand each step before proceeding to the next one.

B. Follow the sequence of steps in the order they are presented. **Do not** skip steps or take any short cuts.

C. Refer to **ALIGNMENT** (page 5) for patterns to be used to align the frame for gluing. When gluing parts together, use a flat toothpick or similar tool to apply a small amount of glue to the parts to be joined. Remove any excess glue promptly with a damp cloth. **Remember to let each glued assembly dry thoroughly before adding the next part.**

D. Begin assembly of the **frame** (see **DETAIL A**, page 3) as follows:

**NOTE:** Before gluing ensure smoothest surfaces face outward to enhance the beauty of your finished piece.

1. Glue top cross member (part no. 79) to two sides (part no. 78).

**NOTE:** Part no. 96 may be used to aid in aligning parts. **Do not** glue.

2. Align parts face down on alignment pattern no. 1 (see **ALIGNMENT**, page 5).
3. Hold, pin, or clamp parts in place until glue sets. (Follow instructions for glue being used for the proper setting time.)

E. Continue assembly of the **frame** (see **DETAIL B**, page 3) as follows:

**NOTE:** Structure should still be in the face down position. Before gluing, small pencil marks on the back at the predetermined dimensions will aid in assembly of this part.

1. Glue lower cross member (part no. 96) to assembled **DETAIL A**, 3-1/2 inches from top cross member (part no. 79).
2. Use clamps to hold parts in place until glue sets.

F. Assemble **rear frame supports** (see **DETAIL C**, page 3) as follows:

1. Glue lower rear frame support (part no. 82) to back of assembled **DETAIL B**, 3-3/8 inches from the bottom and ensure equal distances on either side.
2. Glue upper rear frame support (part no. 82) to back of assembled **DETAIL B**, 3/4 inch from top and ensure equal distances on either side.
3. Use clamps to hold parts in place until glue sets.

G. Assemble **recessed center section** (see **DETAIL D**, page 3) as follows:

**NOTE:** a. Structure should still be in the face down position. Before gluing, small pencil marks on the back at the predetermined dimensions will aid in assembly of this part.

b. When gluing recessed center section (part no. 95) apply glue along outboard 1/4 inch of surface, so there will be no glue deposits visible from front of fireplace.

1. Glue recessed center section (part no. 95) to assembled **DETAIL C**, 1-1/4 inch from either side with top butted directly against upper rear frame support (part no. 82) for squareness.
2. Hold part in place until glue sets.

H. Assemble **frame sides** (see **DETAIL E**, page 3) as follows:

1. Glue two frame sides (parts no. 76) to assembled **DETAIL D**.

**NOTE:** The four side supports (parts no. 83) shall be positioned in the approximate areas shown. The side supports add squareness and rigidity to the frame sides.

2. Glue four side supports (parts no. 83) to frame sides (parts no. 76) and assembled **DETAIL D**.

I. Assemble the **hearth** (see **DETAIL F**, page 3) as follows:

**NOTE:** When installing hearth (part no. 86) ensure notched portion is aligned with rear edge of assembled **DETAIL E**.

1. Glue hearth (part no. 86) to assembled **DETAIL E**.
2. Stand assembly in an upright position and allow glue to set.

J. Begin assembly of the **front frame** (see **DETAIL G**, page 3) as follows:

1. Glue two sides (parts no. 90) to top (part no. 89).
2. Align parts face down on alignment pattern no. 2 (see **ALIGNMENT**, page 5).
3. Pin to hold parts in place until glue sets.

K. Assemble the **front frame** (see **DETAIL H**, page 3) as follows:

**NOTE:** Structure should be face up. Before gluing, small pencil marks on the extreme lower part of the structure at the predetermined dimensions will aid in assembly of this part.

1. Position assembled **DETAIL G** on front of assembled **DETAIL F** maintaining a 3/8 inch dimension on either side and flush with bottom.
2. Hold part in place until glue sets.

L. Assemble moldings (see **DETAIL I**, page 3) as follows:

**NOTE:** Use the Mitre Box, X-ACTO No. 533 and the Razor Saw Set, X-ACTO No. 4055C to obtain a straight clean cut. Also, use the **Molding Configuration List** (see **INTRODUCTION**, page 1) to identify the molding number with the actual molding configuration.

1. Straight cut two lengths 4-1/4 inches long from molding (part no. 94).
2. Glue two moldings (part no. 94) to assembled DETAIL H.

M. Begin assembly of the **mantle** (see **DETAIL J**, page 3) as follows:

1. Glue mantle support (part no. 84) to mantle (part no. 85).
2. Align parts on alignment pattern no. 3 (see **ALIGNMENT**, page 5).
3. Use clamps to hold parts in place until glue sets.

N. Assemble the **mantle** (see **DETAIL K**, page 3) as follows:

**NOTE:** Ensure assembled DETAIL J is centered on front frame.

1. Glue assembled DETAIL J to assembled DETAIL I.
2. Hold part in place until glue sets.

O. Begin assembly of the **fire box** (see **DETAIL L**, page 3) as follows:

**NOTE:** The **fire box sides** (part no. 88) and fire box back (part no. 87) have been designed with chamfered edges. This ensures the proper angle is obtained after gluing.

1. Glue fire box sides (part no. 88) to fire box back (part no. 87).
2. Align parts on alignment pattern no. 4 (see **ALIGNMENT**, page 5).
3. Hold parts in place until glue sets.

P. Assemble **fire box** (see **DETAIL M**, page 3) as follows:

**NOTE:** Ensure fire box is centered in opening and chamfered edge of fire box touches fireplace frame.

1. Glue assembled DETAIL L to assembled DETAIL K.
2. Hold in place until glue sets.

**NOTE:** a. In the following steps we will be assembling moldings of different sizes and shapes, this is a very time consuming task and should be given your undivided attention. **Take your time** as precision work in this area will greatly enhance the beauty of your fireplace.

b. Use the Mitre Box, X-ACTO No. 533 and the Razor Saw Set, X-ACTO No. 4055C.

c. The **INTRODUCTION** (page 1) contains a **Molding Configuration List** which will help you to identify the actual molding configuration to the molding part no. and a brief explanation of some terms used in the following detailed instructions on mitering moldings.

Q. Assemble **recessed center section molding** (see **DETAIL N**, page 3) as follows:

**NOTE:** Inside molding (see **INTRODUCTION**, page 1).

1. **Miter cut** two pieces molding (part no. 91) 3-1/2 inches long and two pieces 3 inches long.
2. Glue to recessed center section (assembled DETAIL M).
3. Hold in place until glue sets.

R. Assemble **mantle molding** (see **DETAIL O**, page 3) as follows:

**NOTE:** Outside molding. (See **INTRODUCTION**, page 1).

1. **Miter cut** two pieces molding (part no. 92) 1/2 inch long **straight cut** one side.
2. **Miter cut** one piece molding (part no. 92) 6 inches.
3. Glue to mantle (assembled DETAIL N).
4. Hold in place until glue sets.

S. Assemble **hearth molding** (see **DETAIL P**, page 3) as follows:

**NOTE:** Outside molding. (See **INTRODUCTION**, page 1).

1. Assemble **hearth molding**. (See **INTRODUCTION**, page 1).
1. **Miter cut** two pieces molding (part no. 93) 29/32 long **straight cut** one side.
2. **Miter cut** one piece molding (part no. 93) 5-27/32 inches.
3. Glue to hearth (assembled DETAIL O).
4. Hold in place until glue sets.

T. Assemble **fire box molding** (see **DETAIL Q**, page 3) as follows:

**NOTE:** Inside molding. (See **INTRODUCTION**, page 1).

1. **Miter cut** two pieces molding (part no. 93) 3 inches long, **straight cut** one side.
2. **Miter cut** one piece molding (part no. 93) 3 inches long.
3. Glue to chamfered edge of fire box (assembled DETAIL P).

U. Assemble **front frame molding** (see **DETAIL R**, page 3) as follows:

**NOTE:** Inside Molding. (See **INTRODUCTION**, page 1).

1. **Miter cut** two pieces molding (part no. 92) 3-1/2 inches long, **straight cut** one side.
2. **Miter cut** one piece molding (part no. 92) 4-1/16 inches long.
3. Glue to front frame (assembled DETAIL Q).
4. Hold in place until glue sets.

V. You have now completed assembly of your fireplace. The completed piece should look like that shown in **DETAIL S**. Lightly sand all joint areas to remove excess glue using 220 grit sandpaper. Moisten a cloth slightly and rub the surface to remove all particles of wood. When all signs of moisture have gone from the wood, paint with a high quality paint of your choice.

# ALIGNMENT

A. Tape this sheet to a smooth, flat surface. Then tape sheet of waxed paper to the pattern so that any excess glue at the joint will not stick to the pattern, making it difficult to remove the completed assembly.

B. Use the alignment patterns shown here to position the indicated parts properly and to hold them in alignment while drying. The arrowheads show the points to insert the straight pins to properly secure the parts.

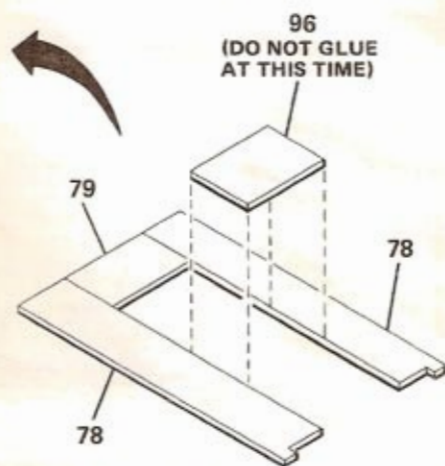
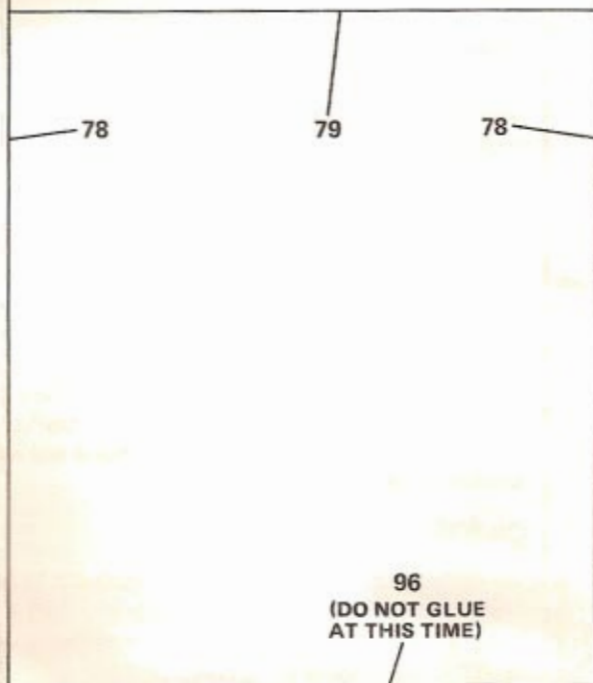

PATTERN 1



PATTERN 2

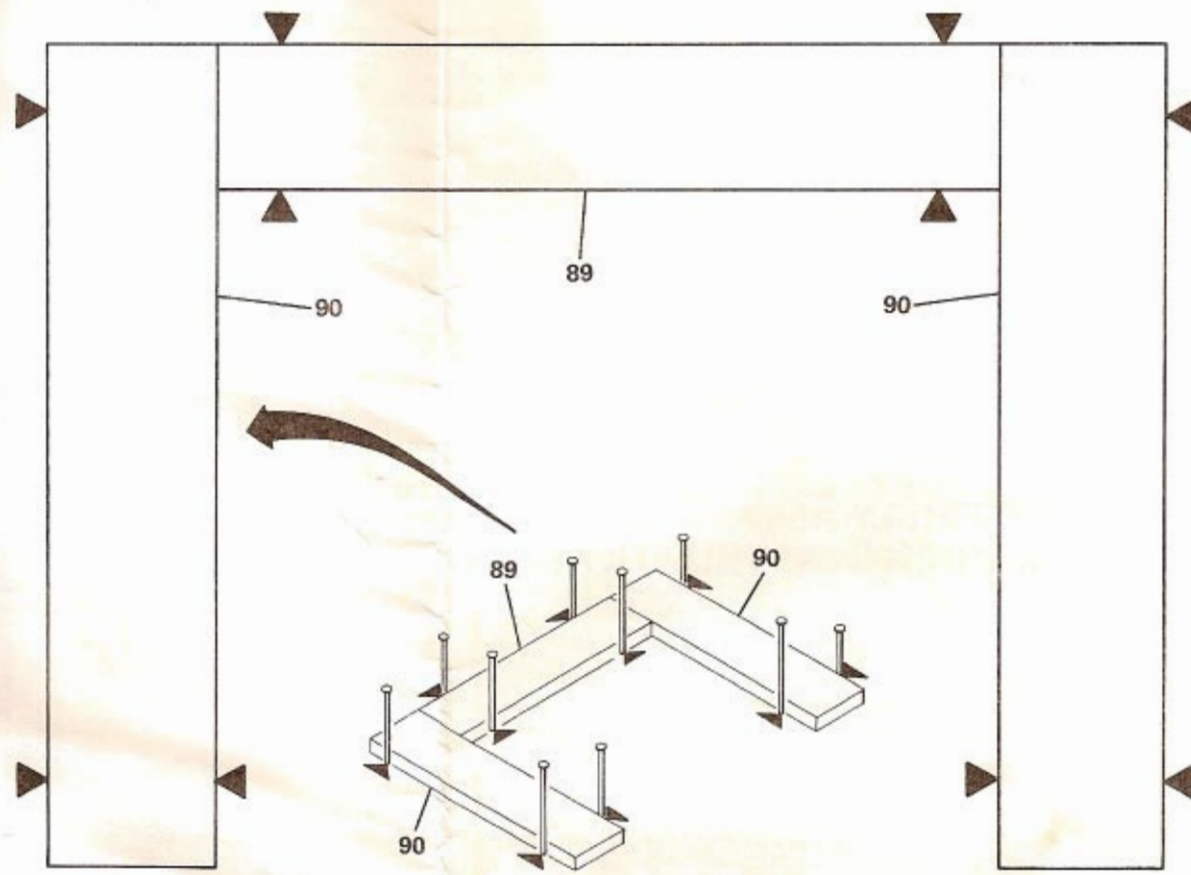

PATTERN 3

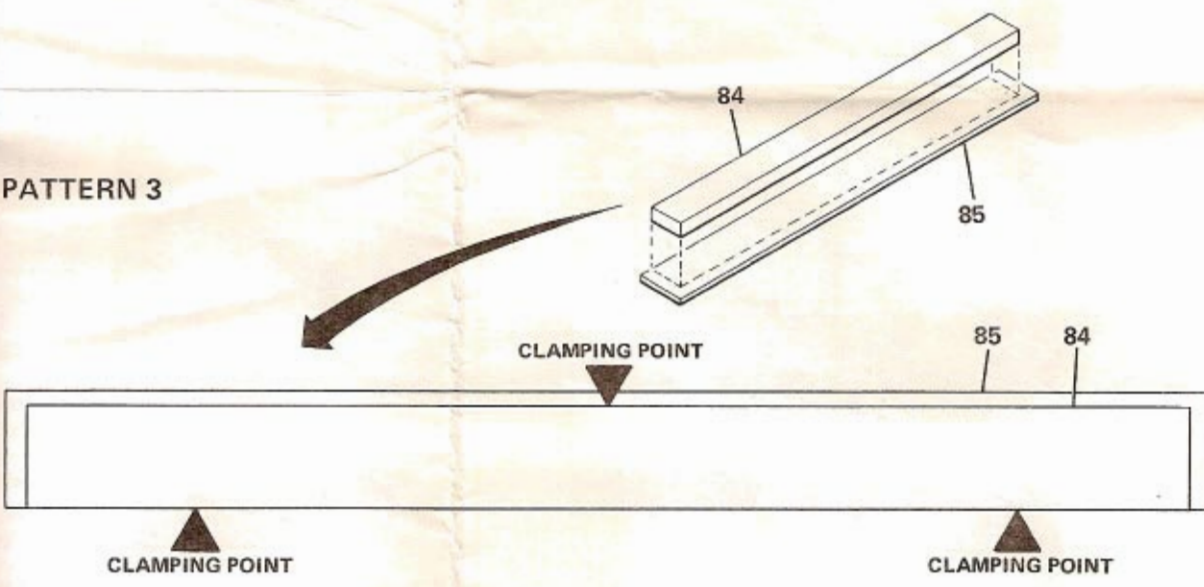

PATTERN 4

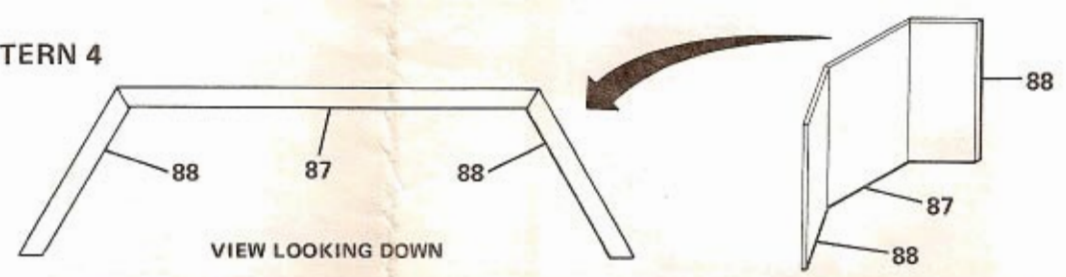

Every effort has been made to insure the completeness of this KIT—however, should any parts be missing, write directly to:  
 X-ACTO/THE HOUSE OF MINIATURES  
 45-35 Van Dam Street  
 Long Island City, N.Y. 11101



When ordering missing parts, please print your name and address plainly. State the missing PART NO. (See LAYOUT SHEET page 2), KIT NO. 40020 and the Kit Name, "TIDEWATER VIRGINIA FIREPLACE."