



Chippendale  
Style Wing Chair  
Circa 1750-1790

Few furniture designers become influential enough to have their names rather than a monarch's linked with current styles.

One of these was Thomas Chippendale, who operated one of the most fashionable shops in London from 1745 until his death in 1777.

Wing chairs generally known as "easy" chairs were popular in our country for more than 100 years, about 1700-1810. The distinctive features in all types of wing chairs are the high backs, the arms and the "wings". The wings were meant not only to make the chair comfortable, but also to protect the occupant from strong drafts which resulted from the open fires in the homes of our ancestors. The upholstery of the chair was as important as the cabinet work. In the homes of well-to-do families, the best needle work was often used, covering the entire visible surface of the chair except for the legs and feet.

The Chippendale style chairs are perhaps the most elegant in appearance of any of the wing types. His earlier chairs had cabriole legs, generally with ball and claw feet, and the later ones with straight square legs and stretchers. The arms are attached to the wings rather than the back of the chair. Mahogany was the usual wood in this type of chair.



AUTHENTIC REPRODUCTIONS IN MINIATURE

The CRAFTMARK House of Miniature Collectors Series of furniture and accessories have all been carefully researched by specialists through major museum and library collections to assure the highest quality of authenticity in reproduction. Details are extraordinarily accurate to satisfy the most discriminating miniaturist.

All wood parts are machined to assure accurate and precise acceptance of each piece by another.

For a complete catalog of the CRAFTMARK HOUSE OF MINIATURES furniture line and accessories, write to:

THE HOUSE OF  
MINIATURES  
Customer Service-Catalog Dept.  
147 Lake Street  
Delaware, OH 43015

Please include \$2.00 for  
Postage & Handling.

## INTRODUCTION

### BEFORE STARTING

Identify and account for each part by placing it on the Layout Sheet (make sure the correct layout sheet is used when working on multi-kit Instruction Sheets). Should any parts be missing, send a post card to:

**THE HOUSE OF MINIATURES**  
Customer Service - Parts Dept.  
147 Lake Street  
Delaware, OH 43015

Please print Name, Address, Part Number (Number from Layout Sheet) and Kit Name and Number on card when ordering.

### SANDING

Before assembly, sand all the outer surfaces of individual parts with 220 grit sandpaper, or finer, sanded in the same direction as the wood grain until the surface is smooth. Take care not to round any edges or corners of the pieces. Finish sanding with 280 grit sandpaper.

### PRE-ASSEMBLY

A. After sanding, check the proper location and fit of each part by assembling parts loosely, without gluing. Use the DETAIL VIEWS as a guide.

B. All parts for CRAFTMARK kits are made on precision milling machines. When adjustments are required, sand to fit.

### TOOLS AND MATERIALS

- A. The following tools will be helpful in constructing this kit:
1. Knife with blade
  2. Two-inch Sander
  3. Large Clamp
  4. Small Clamp
  5. CRAFTMARK Professional Finishing Kit (or equivalent, see note)
- B. The following materials will be needed to construct this kit:
1. CRAFTMARK Tinted Glue (see note)
  2. Waxed paper
  3. Sandpaper-220 and 280 grit
  4. Small Scissors
  5. White glue (or equivalent)
  6. Small Artist's Brush

**NOTE:** The CRAFTMARK tinted glue is matched to the finish used in the Professional Finishing Kit. This will produce the authentic finish of the period in which the original Furniture was produced. When not using our glue follow manufacturer's directions.

### GLUING

- A. Glue should be applied in small amounts to surface being joined. When gluing dado joints apply glue to dado only.
- B. To ensure a tight fit, squeeze excess glue out of the joints. Hold glued parts together with clamps, rubber bands or weights on the parts.
- C. Wipe off excess glue promptly.
- D. Be sure a glued assembly has dried thoroughly before adding parts.

### FINISHING

The CRAFTMARK Professional Finishing Kit enables you to finish your furniture by the same process used by the professional furniture maker. The end result is what is important—there are easier methods, but none that will give the quality results that this process will. If you use a finish other than CRAFTMARK'S refer to the manufacturer's directions.

# Layout Sheet

Kit 40016

51

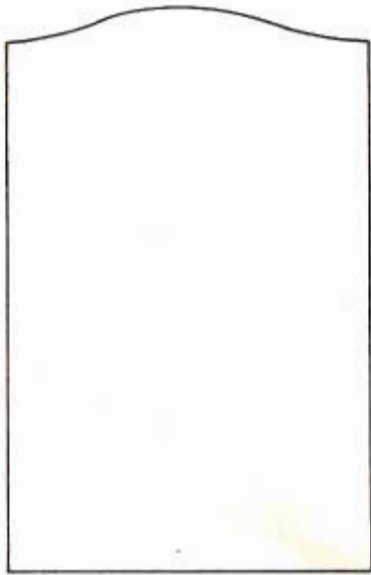

52

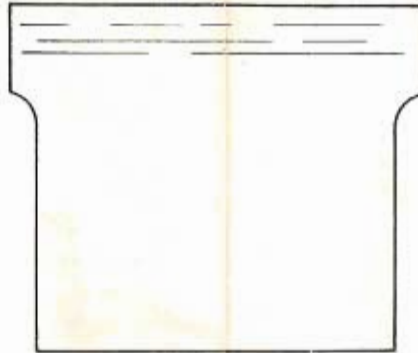

55

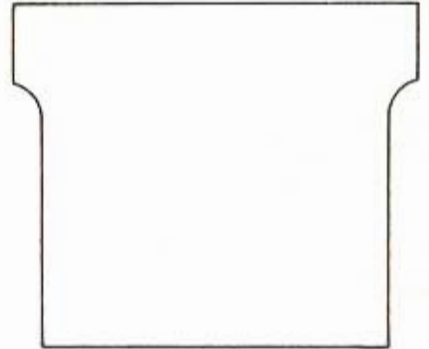

57 (FOAM RUBBER)

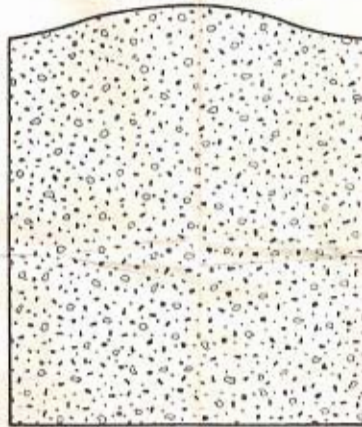

56 (FOAM RUBBER)

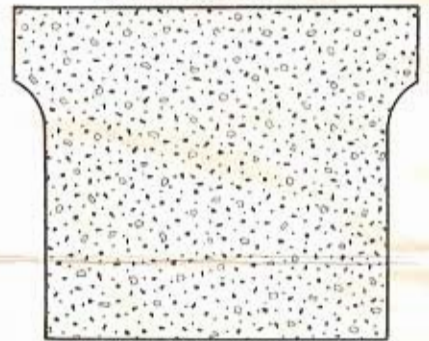

47 (2 REQ'D)

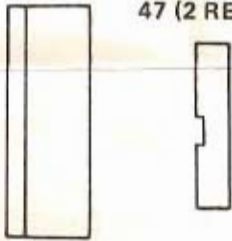

59 (2 REQ'D)



50 (2 REQ'D)

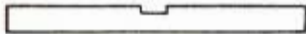

48 (2 REQ'D)

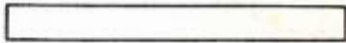

60 28

53

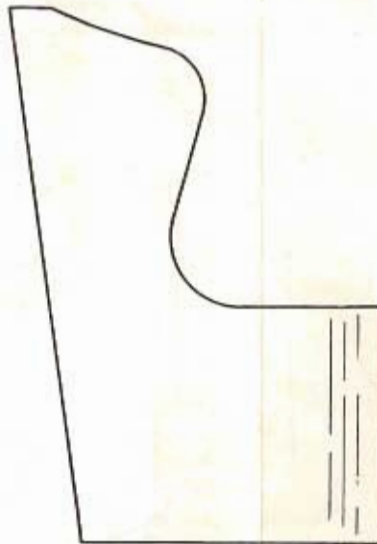

54

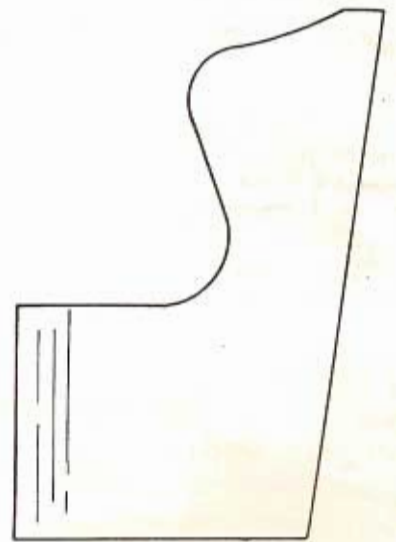

# Detail Views

Kit 40016

## Alignment Pattern

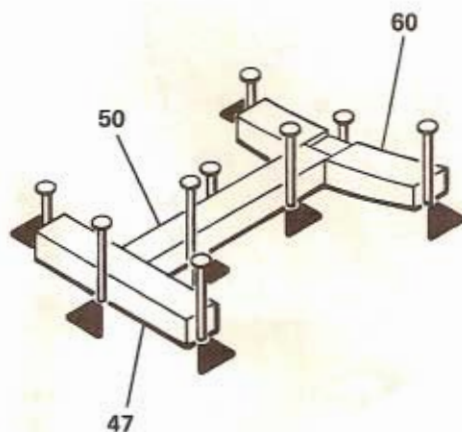
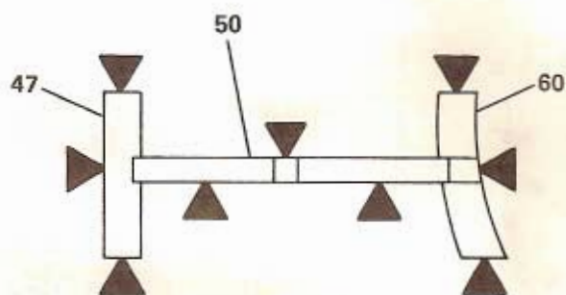

### Step 1

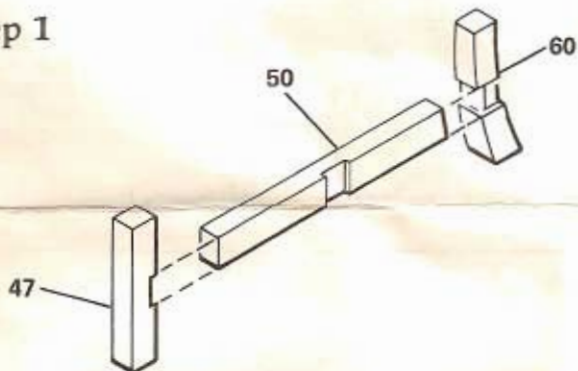

A. Glue front leg (47) to spreader (50), then glue rear leg (60) to spreader (50).

B. Place on Alignment Pattern until glue is dry.

C. Construct second leg set using rear leg (28) in place of (60). Spreader (50) should have notch facing in opposite direction.

### Step 2

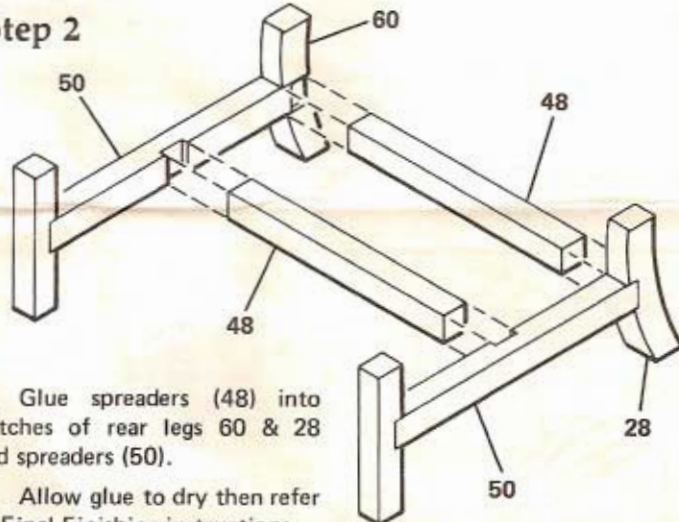

A. Glue spreaders (48) into notches of rear legs 60 & 28 and spreaders (50).

B. Allow glue to dry then refer to Final Finishing instructions.

### Step 3

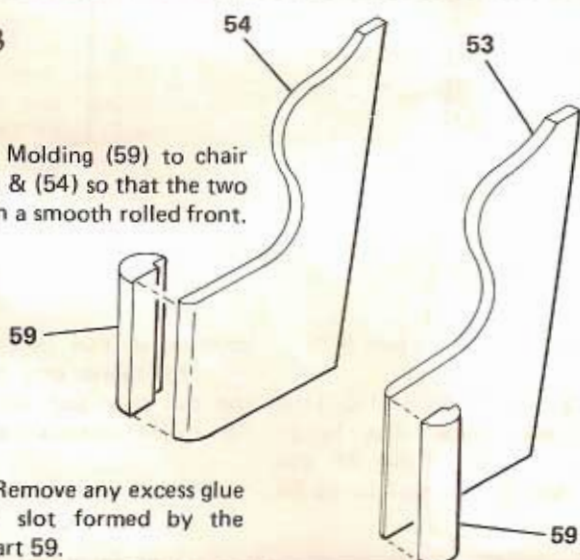

A. Glue Molding (59) to chair sides (53) & (54) so that the two parts form a smooth rolled front.

**NOTE:** Remove any excess glue from the slot formed by the dado in part 59.

### Step 4

A. Glue foam cushion (56) to cushion base (55).

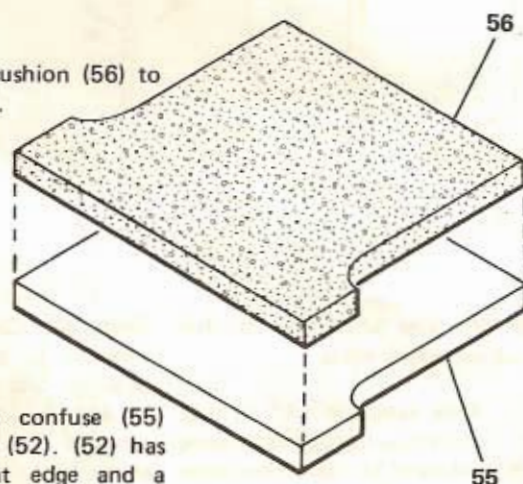

**NOTE:** Do not confuse (55) with chair base (52). (52) has a rounded front edge and a beveled rear edge while all edges on (55) are square.

# Detail Views

Kit 40016

## Step 5

PATTERNS REQUIRING UPHOLSTERY ( DOTTED LINE INDICATES TRIM SIZE OF FABRIC)

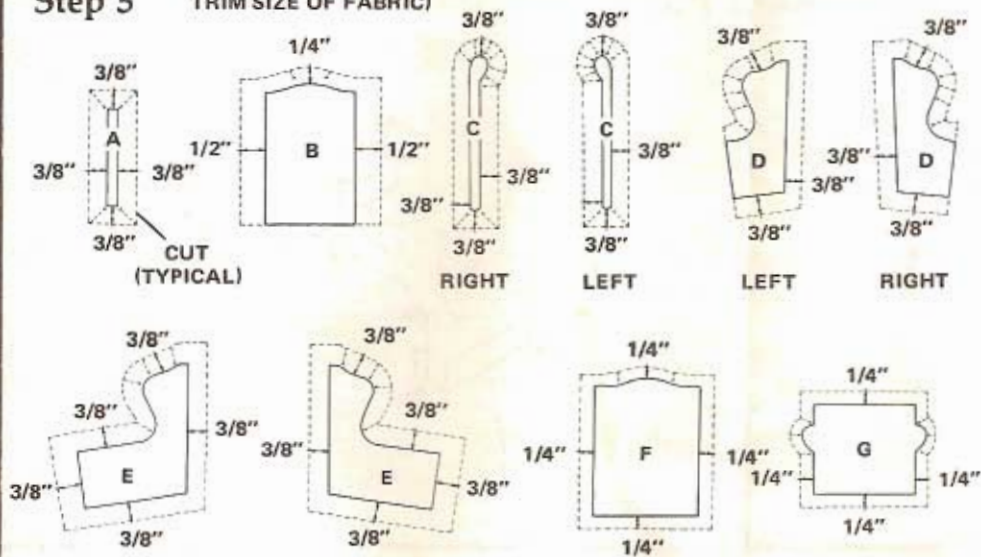

PRE-CUT PATTERNS

ASSEMBLIES REQUIRING UPHOLSTERY

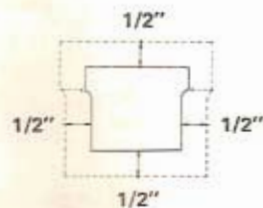

PATTERN FOR SEAT PART NO. 52

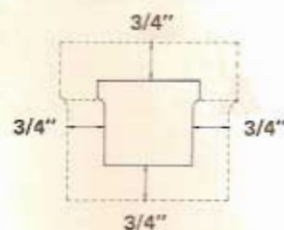

PATTERN FOR SEAT CUSHION NO'S. 55 & 56

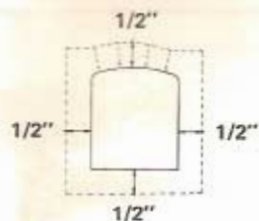

PATTERN FOR BACK CUSHION PART NO. 57 (FOAM)

A. Layout templates on upholstery material. Do not attach or cut at this time. Each template must be trimmed to size before covering with material.

## Step 6

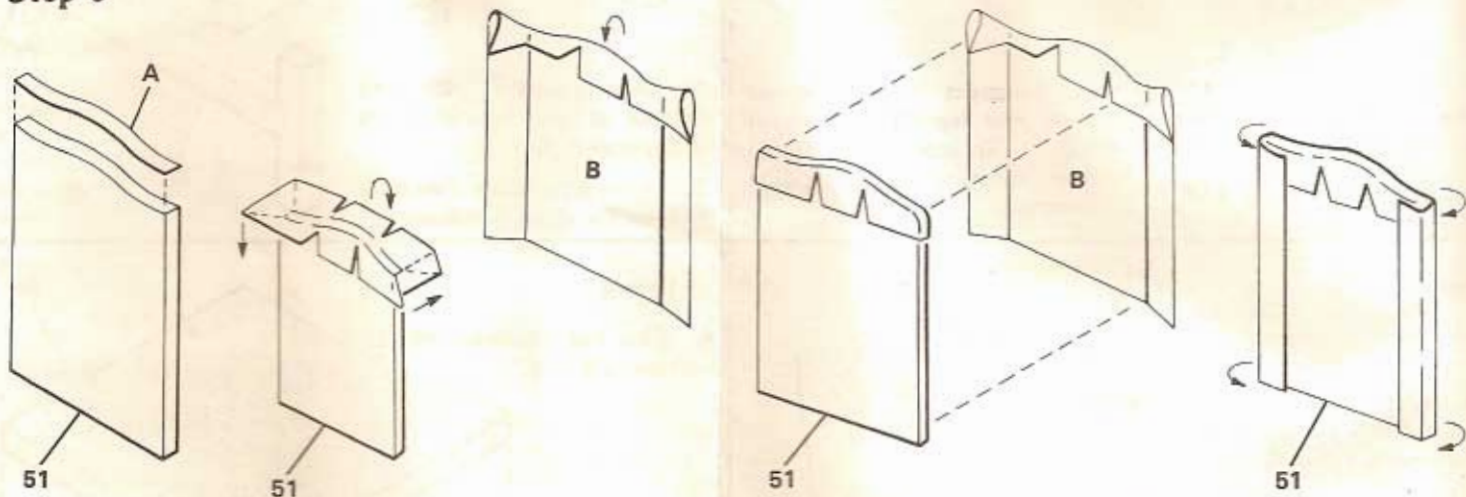

**NOTE:** Use white glue for this and successive steps.

A. Trim template "A" so that it fits the top edge of chair back (51). Attach to fabric and trim

(Step 5). Cover top of (51) clipping at curves to prevent wrinkles. Use white glue sparingly and avoid getting glue on surfaces that will be exposed on finished piece.

B. Trim "B" to fit part (51).

**NOTE:** The bottom of (51) has a beveled edge. The longer surface is the front of this part and is the surface to be

covered at this point. Attach "B" to fabric and fold over the top only and glue. Attach "B" to (51) and cover sides.

# Detail Views

Kit 40016

Step 7

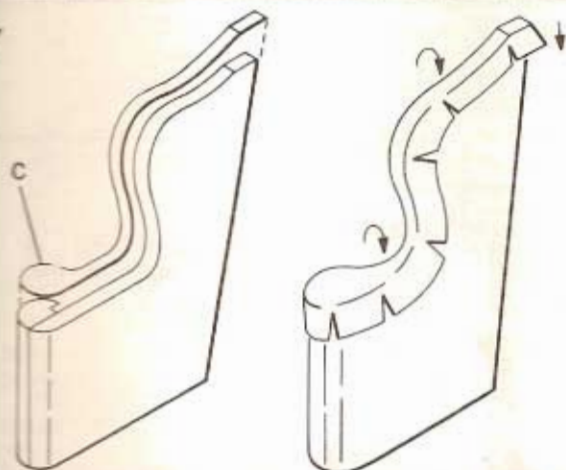

Trim "C" to fit arm and side assembly. Attach fabric, glue "C" to arm then

glue down fabric, clipping curves as you work from front to back. Repeat for other arm.

Step 8

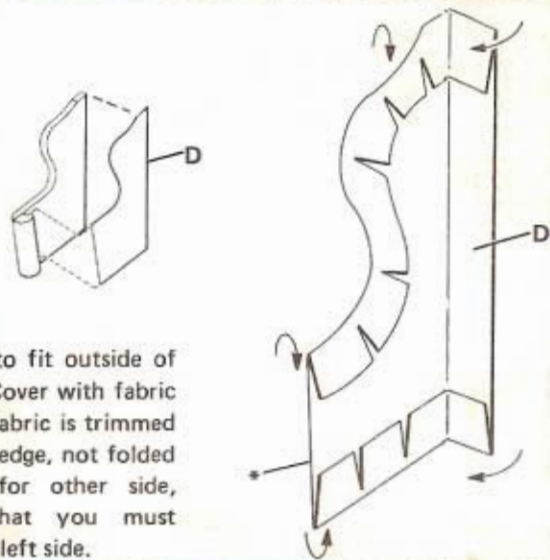

A. Trim "D" to fit outside of arm assembly. Cover with fabric as indicated. \*Fabric is trimmed flush with this edge, not folded over. Repeat for other side, remembering that you must have a right and left side.

Step 9

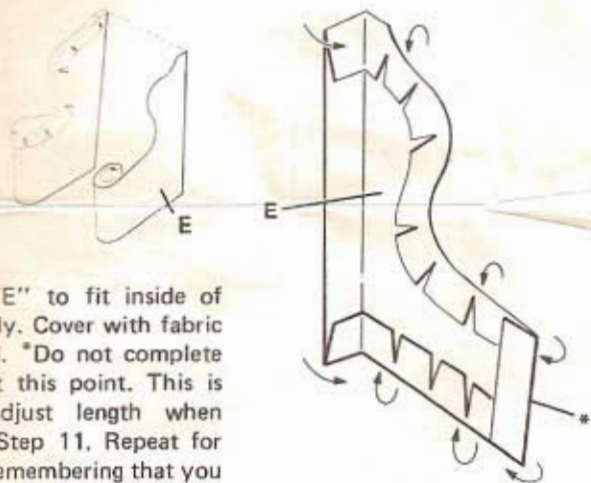

Trim "E" to fit inside of arm assembly. Cover with fabric as indicated. \*Do not complete fold at this point. This is needed to adjust length when applied in Step 11. Repeat for other side remembering that you must have a right and left side.

Step 10

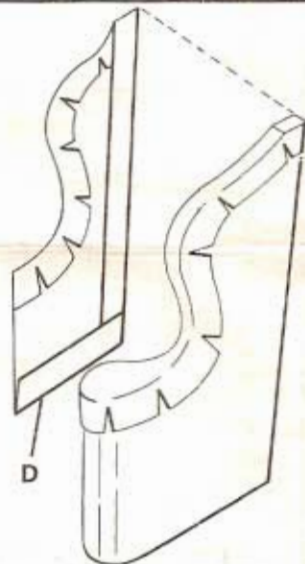

A. Glue fabric covered "D" to outside of arm working front edge into the slot formed by pieces (53) & (59) [or (54 & (59))]. If fabric applied in Step 7 interferes, clip or force it to one side until slot is clear. Repeat for opposite arm.

Step 11



Glue fabric covered "E" to side of arm. Before gluing around the front of the arm check the length and shorten or lengthen as needed, complete covering, the glue to the arm. Repeat for other arm.

Step 12

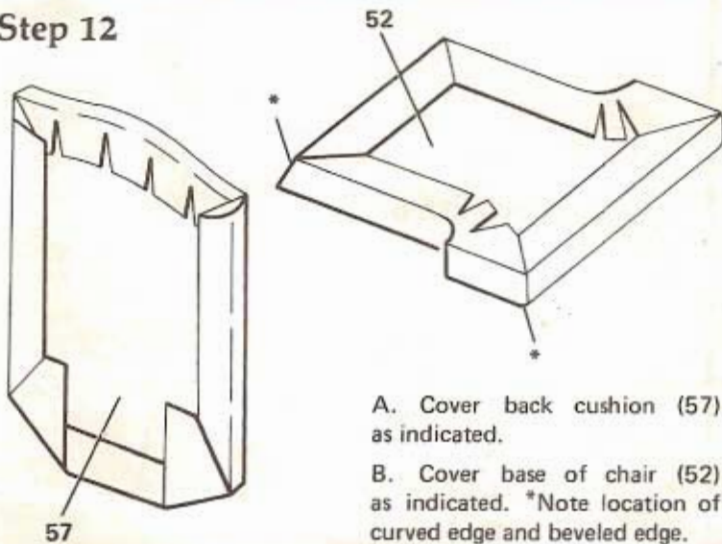

A. Cover back cushion (57) as indicated.

B. Cover base of chair (52) as indicated. \*Note location of curved edge and beveled edge.

# Detail Views

Kit 40016

## Step 13

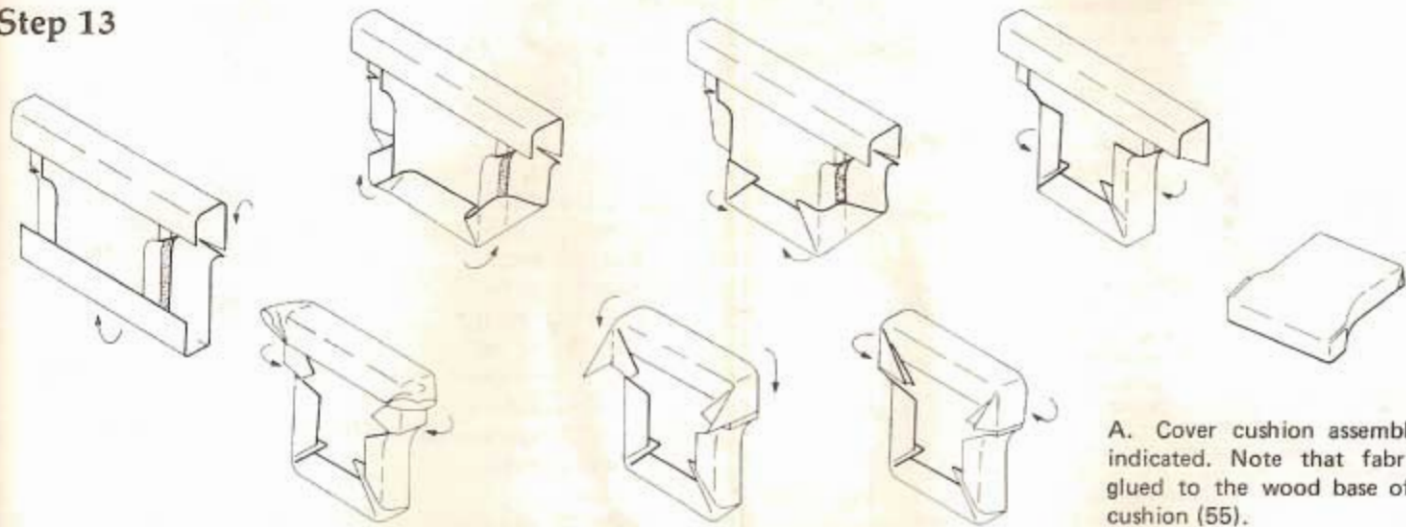

A. Cover cushion assembly as indicated. Note that fabric is glued to the wood base of the cushion (55).

## Step 14



A. Glue the base (Step 12) to the back (Step 6). Then glue the arms (Step 11) in place. When gluing this assembly saturate the fabric on the edges to be joined with glue so that a tight bond is created.

## Step 15

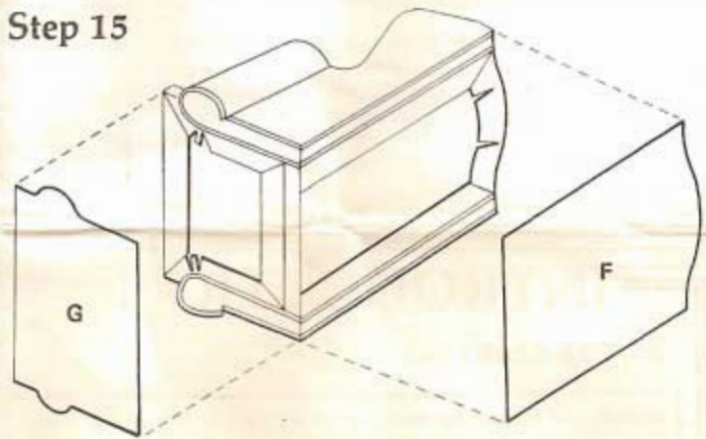

A. Trim templates "G" & "F" to fit.

## Step 16

A. Cover templates "G" and "F" with fabric.

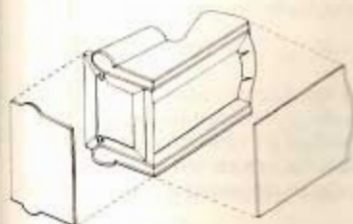
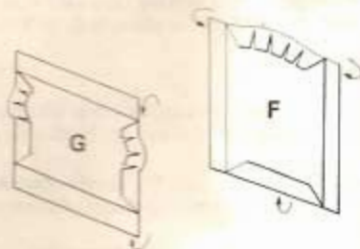

B. Glue "G" & "F" onto chair assembly.

## Step 17

A. Glue finished leg assembly (Step 1 & 2) to the base of the chair.

B. Put bottom cushion in place and then the back cushion.

