

COLLECTORS NO. 40007

Side Chair



A basic side chair typical of many built in the early 1800's. Variations of this design was used by craftsmen such as Phyfe.

Almost all were made of mahogany. The front legs are called saber-leg due to the sharp incurved profile similar to a saber. These legs were often ornately carved in a leaf, water, or acanthus leaf design. They were sometimes finished off with a paw or claw design. The rear legs were almost square and tapered slightly rearward.

Most of the variations in this chair occurred in the splat which is the central member in the chair back. Ornate lyre or fiddle back shapes were used, either made from decorative wood or ornately carved.

Chairs with a horizontal central member as this one often used highly grained wood for decoration or could be ornately carved or painted.

## ASSEMBLY AND FINISHING INSTRUCTIONS



**AUTHENTIC REPRODUCTIONS IN MINIATURE**

The X-ACTO® House of Miniatures Collectors Series of furniture and accessories have all been carefully researched by specialists through major museum and library collections to assure the highest quality of authenticity in reproduction. Details are extraordinarily accurate to satisfy the most discriminating miniaturist.

Every item in the line is an authentic reproduction in miniature of regular-size furniture created by master craftsmen during the Colonial period, precision scaled, one inch to one foot.

All wood parts are machined to assure accurate and precise acceptance of each piece by another.

The rooms illustrated have been completed using standard X-ACTO® HOUSE OF MINIATURES products. All individual components are available.

For a complete catalog of the X-ACTO® HOUSE OF MINIATURES furniture line and accessories, write to:

X-ACTO/ THE HOUSE OF MINIATURES  
Dept. KIT 45-35 Van Dam Street, Long Island  
City, New York 11101.

Please include \$1.00 for postage and handling.

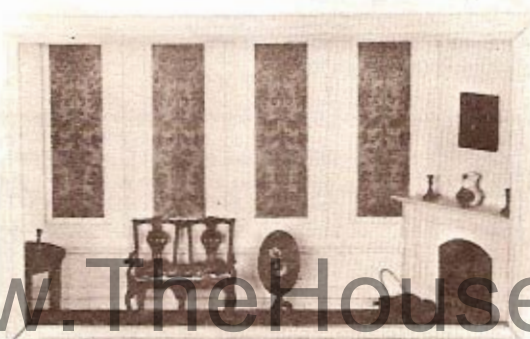
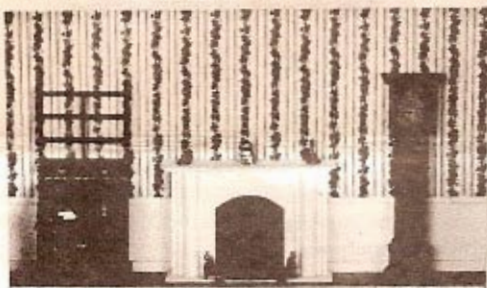

# X-ACTO

# INTRODUCTION

## INSTRUCTIONS BEFORE STARTING

### before starting

Identify and account for each part by placing it on the **LAYOUT SHEET** (Page 2). This will indicate, at a glance, whether any parts are missing. **(See instructions at bottom of last sheet to order missing parts.)**

### sanding

**NOTE:** When using sandpaper, remember that the higher the grit number, the finer the finish.

A. One sanding method that has proved successful is the use of a sanding platform. Tape a sheet of sandpaper of the proper grit size to a hard flat surface such as a table top or wood block. Press down **lightly** and move the piece to be sanded **in the same direction** as the wood grain until the surface is smooth. **Take care not to round any edges or corners of the pieces.**

B. Before assembly, sand all the outer surfaces of individual parts with 220 grit sandpaper, or finer, paying particular attention to edges that will be exposed after assembly. After sanding each piece thoroughly, finish sanding with 400 grit sandpaper. Remember, your final stained finish will only be as smooth as the surface under it.

### gluing

A. Glue should be applied in small amounts to both surfaces being joined. On end cuts, it may be necessary to apply a second coat of glue before joining the parts.

B. To ensure a tight fit, squeeze excess glue out of the joints by holding glued parts together with either clamps, rubber bands or by placing weights on the parts.

C. Wipe off excess glue promptly with a damp cloth.

D. Be sure a glued assembly has dried thoroughly before adding any more parts.

### tools and materials

A. The following tools **will be helpful** in constructing this kit:

1. Knife, X-ACTO No. 1, with Blade, X-ACTO No. 11
2. Two-inch Sander, X-ACTO No. 42
3. Large Clamp, X-ACTO No. 4004
4. Swiss Needle File Set, X-ACTO No. 60S
5. Professional Finishing Kit, X-ACTO No. 43801
6. Power Sprayer, X-ACTO No. 43561

B. The following materials **will be needed** to construct this kit:

1. Waxed paper
2. Sandpaper - 220, 320 and 400 grit
3. Steel wool - Grade 000
4. Fabric included. **(Other X-ACTO Fabric Shades, Series 42100 through 42107 available)**
5. Wood stain of your choice. **(See Note)**
6. Glaze stain of your choice. **(See Note)**
7. Lacquer or varnish of your choice. **(See Note)**
8. White glue, or any good wood glue. **(See Note)**
9. Sealer **(See Note)**

**NOTE:** The X-ACTO No. 43801 Professional Finishing Kit will produce the authentic Mahogany finish of the period in which the original furniture was produced. Base stain, glaze stain, lacquer or varnish, sealer and glue are required only if the X-ACTO Professional Finishing Kit is not used.

### pre-assembly

A. After sanding, check the proper location and fit of each part by assembling parts loosely, without gluing. Use the **DETAIL VIEWS** (Page 3) as a guide.

B. All parts for X-ACTO kits are made on precision milling machines, using rabbet and dado joints. Parts will fit together snugly with very little adjustments required. When adjustments are required, sand or file to fit.

# LAYOUT SHEET

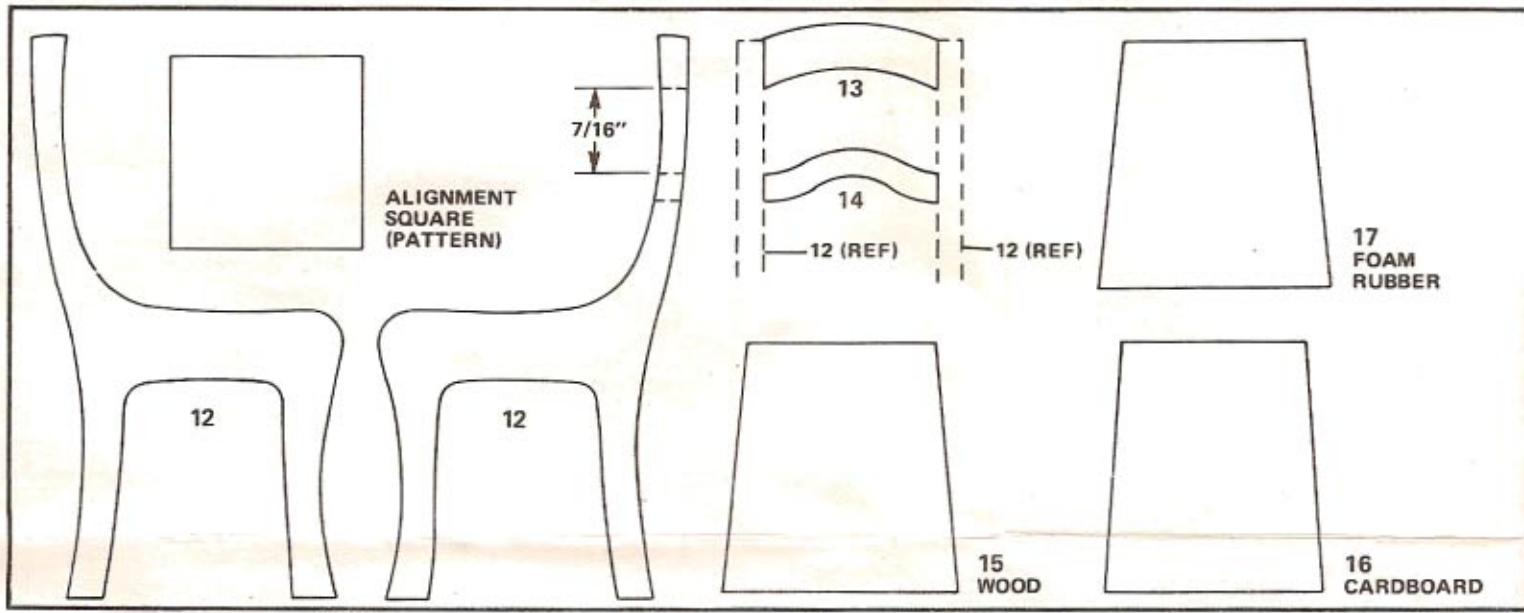

## DETAIL VIEWS

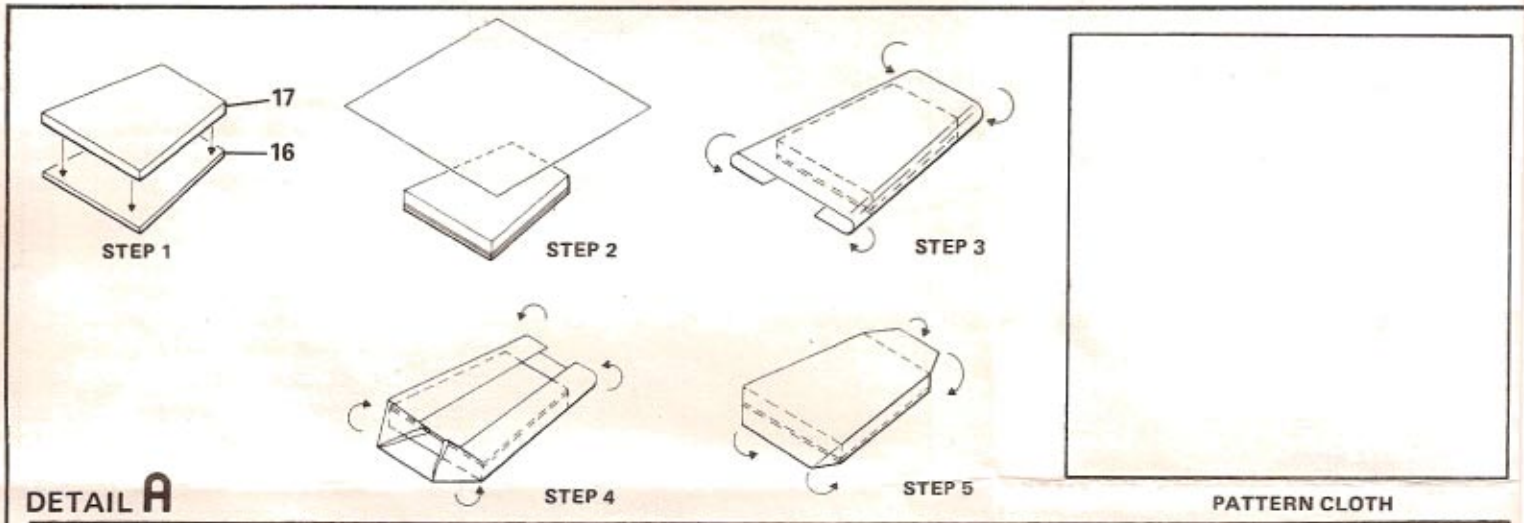

### DETAIL A

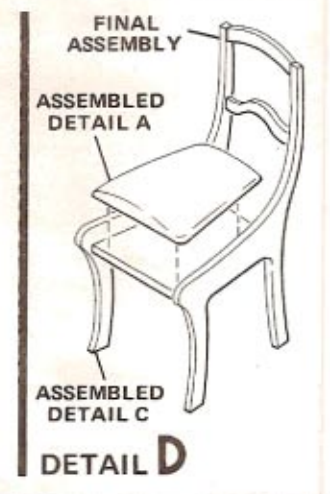
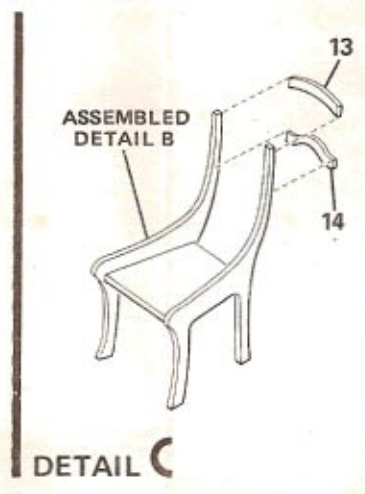
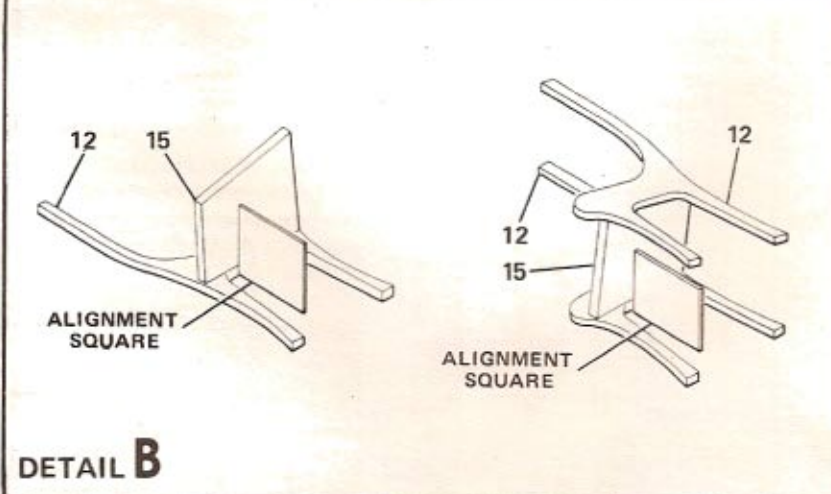

# ASSEMBLY

A. Before starting to assemble your kit, study all illustrations and instructions carefully. Be certain you understand each step before proceeding to the next one.

B. Follow the sequence of steps in the order they are presented. **Do not** skip steps or take any short cuts.

C. When gluing parts together, use a flat toothpick or similar tool to apply a small amount of glue to the parts to be joined. Remove any excess glue promptly with a damp cloth. **Remember to let each glued assembly dry thoroughly before adding the next part.**

D. The Professional Finishing Kit, X-ACTO No. 43801, will produce the authentic Mahogany finish of this period and contains a **matching tinted glue**, which is recommended for assembly of this kit. The **tinted glue** is of furniture grade quality, equivalent to that used by professional cabinet makers and its use will avoid the appearance of a glue line at each joint.

E. Assemble **seat cushion** (see **DETAIL A**, page 2) as follows:

1. Glue foam cushion (part no. 17) to cardboard (part no. 16).
2. Transfer pattern for seat cushion onto fabric. Cut out fabric.
3. Place fabric as shown in step 3 over foam cushion (part no. 17).
4. Fold the two sides under and glue to cardboard (part no. 16) using white glue.
5. Tuck each corner under.

6. Fold the front and rear of fabric under and glue in place.

F. Assemble **frame** (see **DETAIL B**, page 2) as follows:

1. Place side of chair (part no. 12) on a flat surface. Glue seat (part no. 15) to side (part no. 12). Use alignment square for proper alignment. Ensure seat (part no. 15) tapers to back of chair and seat bottom is flush with bottom of side rail. Allow glue to dry. (Follow the instructions for the glue being used for the proper setting time.)

2. Glue opposite side (part no. 12) to seat (part no. 15). Use alignment square for proper alignment, allow glue to dry.

G. Assemble **chair back** (see **DETAIL C**, page 2) by gluing part no.'s 13 and 14 to assembled **DETAIL B**. See layout sheet for alignment.

H. You have now completed assembly of your furniture with the exception of the attachment of the fabric seat cushion. Proceed now to **FINAL FINISHING**.

I. After **FINAL FINISHING** has been accomplished, attach the fabric seat cushion (see **DETAIL D**, page 2) by gluing cushions as assembled in **DETAIL A** to seat.

J. You have now completed assembly of your furniture. The completed piece should look like that shown in **DETAIL C**, (page 2).

## FINAL FINISHING

In order to ensure that your piece is stained and highlighted in the tones of the period in which the original furniture was produced, we recommend that X-ACTO Professional Finishing Kit, No. 43801 be used. The following method is used by professional furniture makers, and, if done properly, will result in museum quality.

A. After assembly is completed and the glue has set, **lightly** sand all joint areas to remove excess glue, using 220 grit sandpaper or finer. Moisten a cloth slightly and rub the dampened cloth over the entire wood surface to raise the grain. When all signs of moisture have gone from the wood, resand using a 320 to 400 grit sandpaper.

B. With a small brush, apply a light sealer coat to all edges and end grains. Use the side of the brush rather than the tip, in a wiping motion, so that the sealer does not touch other surfaces. Sealing the edge and end grains will prevent the subsequent stains from penetrating these areas as deeply, resulting in a more uniform stain on all parts.

**NOTE:** If the X-ACTO Finishing Kit (which contains a high quality sealer) is not used, thinned varnish or lacquer can be used for this purpose.

C. To match the color of furniture of this period apply **X-ACTO Base Stain** or mahogany or cherry stain of your choice with a brush or cloth over the entire wood surface. Immediately wipe off all excess stain leaving an even color on the surface. Allow to dry.

D. Apply a thin coat of **X-ACTO Sealer** or any commercial wood sealer over the base stain. This can be applied with either a brush or with the **X-ACTO Power Sprayer**. Make sure there are no drip marks present. Allow the sealer to dry for at least 6 hours.

X-ACTO POWER SPRAYER No. 43561 can be used to apply sealer, top coat, and paints for outstanding results. This spray ensures application of an even coat, especially on intricate and flat surfaces, and it is highly recommended for finishing your furniture.

E. Lightly go over all surfaces with Grade 000 steel wool until they are smooth to the touch.

F. "**Highlighting**" is a technique of creating light and dark areas and is accomplished by applying the **X-ACTO Glaze Stain** or any commercial glaze stain of your choice (Van Dyck Brown is the color recommended) and then toning by rubbing off the glaze in certain areas, exposing the base stain. In order to "highlight", apply a dark glaze with a brush or rag over the entire piece of furniture. As soon as you have applied this glaze, wipe off the excess. Blend tones of base color and glaze stain by using a piece of soft cloth. There should never be a sharp line of dark color to light color, but rather a smooth blending effect. Lighten the middle surface of the wood, but do not lighten the entire surface. The "**highlighting**" technique will produce museum quality miniature furniture.

G. After the glaze stain has dried for 24 hours, thoroughly and briskly wipe all surfaces with a clean cloth until you are satisfied with the appearance. Apply the **X-ACTO Top Coat** or a coat of lacquer or varnish, with a brush, an airbrush, or with the **X-ACTO Power Sprayer**. Apply two or more top coats with light buffing between coats using Grade 000 steel wool. After each steel wool rubbing make sure all steel wool "dust" is removed thoroughly. **Continue with ASSEMBLY starting with paragraph I.**

Every effort has been made to insure the completeness of this KIT—however, should any parts be missing, write directly to:  
X-ACTO/THE HOUSE OF MINIATURES  
45-35 Van Dam Street  
Long Island City, N.Y. 11101



When ordering missing parts, please Print your name and address plainly. State the missing PART NO. (See LAYOUT SHEET, page 1), KIT NO. 40007 and the Kit Name, "SIDE CHAIR".