

COLLECTORS NO. 40004



Hepplewhite Side Table
Circa early 1800's

All the Hepplewhite style side and card tables were probably made before any decadence in furniture styles took place. The simple graceful tapered lines of the legs are indicative of the Hepplewhite design that has lasted over the many years. The half round side table was most done with mahogany veneers with ornate inlays on the legs and outlining the half round top. Fancy burl veneers were commonly used to enhance the simple yet elegant side table. The side table should not be confused with the card tables of the same period. Card tables, although of the same size, had an extra leg that was used as a support of a second top that folded flat when the table was not extended. When both tops were used it formed a round table and was commonly used as a "socializing table" when tea was served or on which social card games were played.

There are side tables that also had double hinged tops but did not have the fifth support leg. These side tables were commonly used in hallways where the second leaf was folded upward against the wall showing the beautiful veneers and inlays.

The side table was often found in halls, ante rooms, dining rooms and parlors and, in several historic homes, in sleeping salons. This table is a fine example of simple design elegance typical of the fine English cabinet maker, George Hepplewhite.

ASSEMBLY AND FINISHING INSTRUCTIONS



AUTHENTIC REPRODUCTIONS IN MINIATURE.

The X-ACTO® House of Miniatures® Collectors Series of furniture and accessories have all been carefully researched by specialists through major museum and library collections to assure the highest quality of authenticity in reproduction. Details are extraordinarily accurate to satisfy the most discriminating miniaturist.

All wood parts are machined to assure accurate and precise acceptance of each piece by another.

For a complete catalog of the X-ACTO® HOUSE OF MINIATURES furniture line and accessories, write to:

X-ACTO® THE HOUSE OF MINIATURES Dept. KIT
45-35 Van Dam Street
Long Island City,
New York 11101

Please include \$1.00 for postage and handling.

INTRODUCTION

BEFORE STARTING

Identify and account for each part by placing it on the Layout Sheet (make sure the correct layout sheet is used when working on multi-kit Instruction Sheets). Should any parts be missing, send a post card to:

X-ACTO/The House of Miniatures
45-35 Van Dam Street
Long Island City, N.Y. 11101

Please print Name, Address, Part Number (Number from Layout Sheet) and Kit Name and Number on card when ordering.

SANDING

Before assembly, sand all the outer surfaces of individual parts with 220 grit sandpaper, or finer, sanded in the same direction as the wood grain until the surface is smooth. Take care not to round any edges or corners of the pieces. Finish sanding with 280 grit sandpaper.

PRE-ASSEMBLY

- After sanding, check the proper location and fit of each part by assembling parts loosely, without gluing. Use the **DETAIL VIEWS** as a guide.
- All parts for X-ACTO kits are made on precision milling machines. When adjustments are required, sand to fit.

TOOLS AND MATERIALS

A. The following tools will be helpful in constructing this kit:

- Two-inch Sander, X-ACTO No. 42
- Small Clamp, X-ACTO No. 4003
- X-ACTO Professional Finishing Kit (or equivalent, see note)

B. The following materials will be needed to construct this kit:

- X-ACTO Tinted Glue (see note)
- Sandpaper - 220 and 280 grit
- Steel Wool - Grade 0000
- Small Artist's Brush.

NOTE: The X-ACTO tinted glue is matched to the finish used in the Professional Finishing Kit. This will produce the authentic finish of the period in which the original Furniture was produced. When not using X-ACTO glue follow manufacturer's directions.

GLUING

- Glue should be applied in small amounts to surface being joined. When gluing dado joints apply glue to dado only.
- To ensure a tight fit, squeeze excess glue out of the joints. Hold glued parts together with clamps, rubber bands or weights on the parts.
- Wipe off excess glue promptly.
- Be sure a glued assembly has dried thoroughly before adding parts.

FINISHING

The X-ACTO Professional Finishing Kit enables you to finish your furniture by the same process used by the professional furniture maker. The end result is what is important — there are easier methods, but none that will give the quality results that this process will. If you use a finish other than X-ACTO's, refer to the manufacturer's directions.

Layout Sheet

Kit 40004

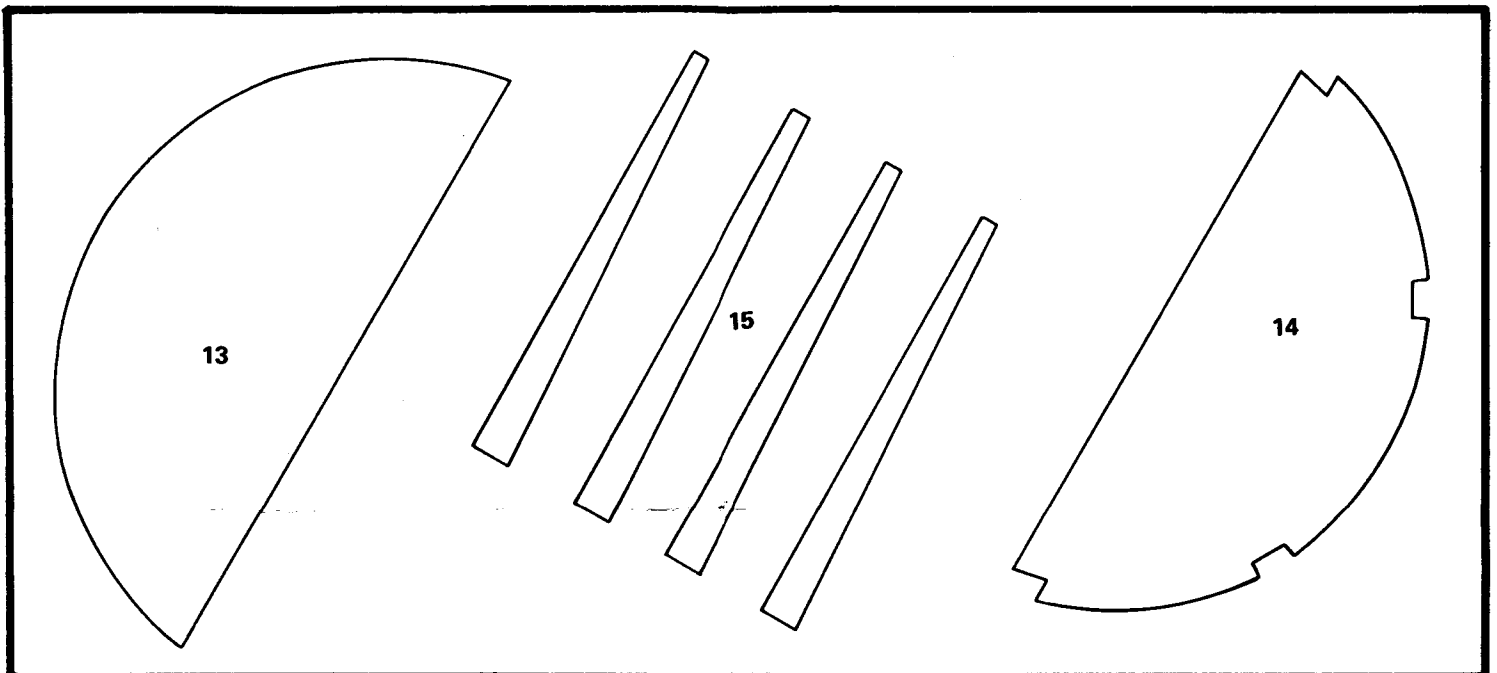

Step 1

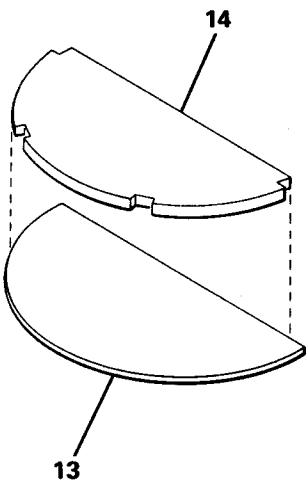
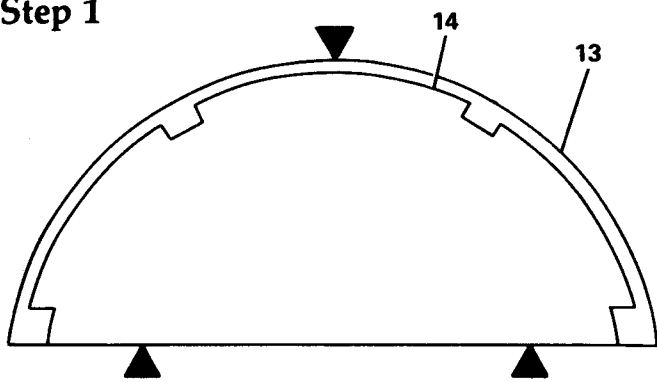

A. Glue top (13) to base (14). Parts should be centered as indicated and back edges should be flush.

B. Clamp at points indicated by large arrows to avoid warping of top (13).

Step 2

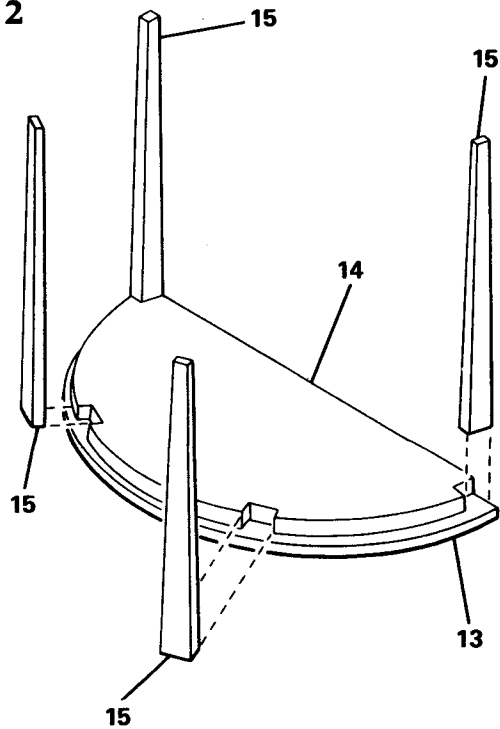

A. Glue legs (15) into dados B. The table is now ready for in top assembly. Inside edges of legs should be perpendicular to top assembly and taper of leg is at the same angle on each side of leg.