

COLLECTORS NO. 40003

Hutch Cabinet
Circa 1750-1790



This particular cabinet base is modeled after the Chippendale cabinets built between 1750 and 1790. These cabinets had many uses within the colonist's house. By themselves they provided useful storage in several rooms of the house.

When topped with either an open cabinet top or a closed cabinet top they became an attractive and useful dining room piece. There the colonist could display his best china, silver, or pewter.

The top drawer was usually provided with a lock to provide some measure of protection to the family silverware. The doors on the bottom either closed in a large storage area or a multiple shelf arrangement.

There resided the fine table linens, or sometimes then, as now, provided a place to tuck away items that they just didn't know what else to do with.

ASSEMBLY AND FINISHING INSTRUCTIONS



AUTHENTIC REPRODUCTIONS IN MINIATURE

The X-ACTO® House of Miniatures Collectors Series of furniture and accessories have all been carefully researched by specialists through major museum and library collections to assure the highest quality of authenticity in reproduction. Details are extraordinarily accurate to satisfy the most discriminating miniaturist.

Every item in the line is an authentic reproduction in miniature of regular-size furniture created by master craftsmen during the Colonial period, precision scaled, one inch to one foot.

All wood parts are machined to assure accurate and precise acceptance of each piece by another.

The rooms illustrated have been completed using standard X-ACTO® HOUSE OF MINIATURES products. All individual components are available.

For a complete catalog of the X-ACTO® HOUSE OF MINIATURES furniture line and accessories, write to:

X-ACTO / THE HOUSE OF MINIATURES
Dept. KIT 45-35 Van Dam Street, Long Island
City, New York 11101.

Please include \$1.00 for postage and handling.



X-ACTO

INTRODUCTION

INSTRUCTIONS BEFORE STARTING

before starting

A. Identify and account for each part by placing it on the **LAYOUT SHEET** (Page 2). This will indicate, at a glance, whether any parts are missing. **(See instructions at bottom of last sheet to order missing parts.)**

B. The LAYOUT SHEET contains a hardware check list. Use this to identify and account for all hardware that comes with the kit.

sanding

NOTE: When using sandpaper, remember that the higher the grit number, the finer the finish.

A. One sanding method that has proved successful is the use of a sanding platform. Tape a sheet of sandpaper of the proper grit size to a hard flat surface such as a table top or wood block. Press down **lightly** and move the piece to be sanded **in the same direction** as the wood grain until the surface is smooth. **Take care not to round any edges or corners of the pieces.**

B. Before assembly, sand all the outer surfaces of individual parts with 220 grit sandpaper, or finer, paying particular attention to edges that will be exposed after assembly. After sanding each piece thoroughly, finish sanding with 400 grit sandpaper. Remember, your final stained finish will only be as smooth as the surface under it.

hardware

A. All hardware to complete this kit is provided. Installation holes for all hardware must be made in accordance with the **ASSEMBLY** instructions that follow. Use the **DETAIL VIEWS** (Page 3) for hole locations.

B. Do not force handle into holes in handle plate. If a hole is too small, enlarge it slightly with a small knife or needle file.

C. Do not install brass hardware until final finishing has been done to avoid staining hardware.

gluing

A. Glue should be applied in small amounts to both surfaces being joined. On end cuts, it may be necessary to apply a second coat of glue before joining the parts.

B. To ensure a tight fit, squeeze excess glue out of the joints by holding glued parts together with either clamps, rubber bands or by placing weights on the parts.

C. Wipe off excess glue promptly with a damp cloth.

D. Be sure a glued assembly has dried thoroughly before adding any more parts.

tools and materials

A. The following tools **will be helpful** in constructing this kit:

1. Knife, X-ACTO No. 1, with Blade, X-ACTO No. 11
2. Tweezer, X-ACTO No. 36
3. One-inch Sander, X-ACTO No. 41
4. Two-inch Sander, X-ACTO No. 42
5. Large Clamp, X-ACTO No. 4004
6. Small Clamp, X-ACTO No. 4003
7. Swiss Needle File Set, X-ACTO No. 60S
8. End Snip Pliers, X-ACTO No. 1510, or Diagonal Cutting Pliers, X-ACTO No. 1505
9. Professional Finishing Kit, X-ACTO No. 43801
10. Power Sprayer, X-ACTO No. 43561

B. The following materials **will be needed** to construct this kit:

1. Straight pins or artist's push pins
2. Rubber bands
3. Waxed paper
4. Sandpaper - 220, 320 and 400 grit
5. Steel wool - Grade 000
6. Masking tape
7. Ruler
8. Wood stain of your choice. **(See Note)**
9. Glaze stain of your choice. **(See Note)**
10. Lacquer or varnish of your choice. **(See Note)**
11. White glue, or any good wood glue. **(See Note)**
12. Sealer **(See Note)**
13. Small Artist's Brush

NOTE: The X-ACTO No. 43801 Professional Finishing Kit will produce the authentic Mahogany finish of the period in which the original furniture was produced. Base stain, glaze stain, lacquer or varnish, sealer and glue are required only if the X-ACTO Professional Finishing Kit is not used.

pre-assembly

A. After sanding, check the proper location and fit of each part by assembling parts loosely, without gluing. Use the **DETAIL VIEWS** (Page 3) as a guide.

B. Parts can be held together to check proper fit with rubber bands or masking tape.

C. All parts for X-ACTO kits are made on precision milling machines, using rabbet and dado joints. Parts will fit together snugly with very little adjustments required. When adjustments are required, sand or file to fit.

INTRODUCTION

INSTRUCTIONS BEFORE STARTING

before starting

A. Identify and account for each part by placing it on the **LAYOUT SHEET** (Page 2). This will indicate, at a glance, whether any parts are missing. **(See instructions at bottom of last sheet to order missing parts.)**

B. The **LAYOUT SHEET** contains a hardware check list. Use this to identify and account for all hardware that comes with the kit.

sanding

NOTE: When using sandpaper, remember that the higher the grit number, the finer the finish.

A. One sanding method that has proved successful is the use of a sanding platform. Tape a sheet of sandpaper of the proper grit size to a hard flat surface such as a table top or wood block. Press down **lightly** and move the piece to be sanded **in the same direction** as the wood grain until the surface is smooth. **Take care not to round any edges or corners of the pieces.**

B. Before assembly, sand all the outer surfaces of individual parts with 220 grit sandpaper, or finer, paying particular attention to edges that will be exposed after assembly. After sanding each piece thoroughly, finish sanding with 400 grit sandpaper. Remember, your final stained finish will only be as smooth as the surface under it.

hardware

A. All hardware to complete this kit is provided. Installation holes for all hardware must be made in accordance with the **ASSEMBLY** instructions that follow. Use the **DETAIL VIEWS** (Page 3) for hole locations.

B. Do not force handle into holes in handle plate. If a hole is too small, enlarge it slightly with a small knife or needle file.

C. Do not install brass hardware until final finishing has been done to avoid staining hardware.

gluing

A. Glue should be applied in small amounts to both surfaces being joined. On end cuts, it may be necessary to apply a second coat of glue before joining the parts.

B. To ensure a tight fit, squeeze excess glue out of the joints by holding glued parts together with either clamps, rubber bands or by placing weights on the parts.

C. Wipe off excess glue promptly with a damp cloth.

D. Be sure a glued assembly has dried thoroughly before adding any more parts.

tools and materials

A. The following tools **will be helpful** in constructing this kit:

1. Knife, X-ACTO No. 1, with Blade, X-ACTO No. 11
2. Tweezer, X-ACTO No. 36
3. One-inch Sander, X-ACTO No. 41
4. Two-inch Sander, X-ACTO No. 42
5. Large Clamp, X-ACTO No. 4004
6. Small Clamp, X-ACTO No. 4003
7. Swiss Needle File Set, X-ACTO No. 60S
8. End Snip Pliers, X-ACTO No. 1510, or Diagonal Cutting Pliers, X-ACTO No. 1505
9. Professional Finishing Kit, X-ACTO No. 43801
10. Power Sprayer, X-ACTO No. 43561

B. The following materials **will be needed** to construct this kit:

1. Straight pins or artist's push pins
2. Rubber bands
3. Waxed paper
4. Sandpaper - 220, 320 and 400 grit
5. Steel wool - Grade 000
6. Masking tape
7. Ruler
8. Wood stain of your choice. **(See Note)**
9. Glaze stain of your choice. **(See Note)**
10. Lacquer or varnish of your choice. **(See Note)**
11. White glue, or any good wood glue. **(See Note)**
12. Sealer **(See Note)**
13. Small Artist's Brush

NOTE: The X-ACTO No. 43801 Professional Finishing Kit will produce the authentic Mahogany finish of the period in which the original furniture was produced. Base stain, glaze stain, lacquer or varnish, sealer and glue are required only if the X-ACTO Professional Finishing Kit is not used.

pre-assembly





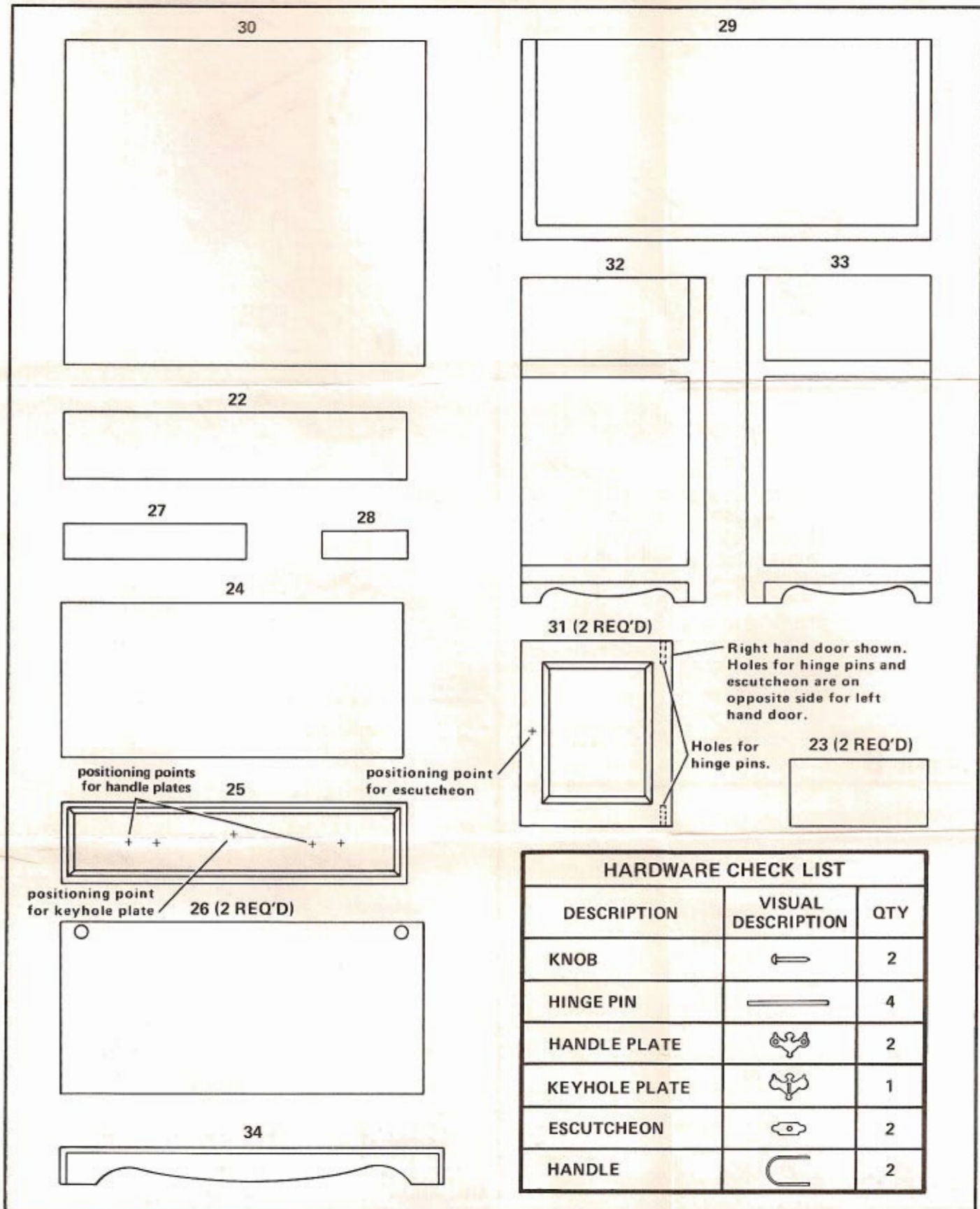

A. After sanding, check the proper location and fit of each part by assembling parts loosely, without gluing. Use the **DETAIL VIEWS** (Page 3) as a guide.

B. Parts can be held together to check proper fit with rubber bands or masking tape.

C. All parts for X-ACTO kits are made on precision milling machines, using rabbet and dado joints. Parts will fit together snugly with very little adjustments required. When adjustments are required, sand or file to fit.

LAYOUT SHEET



HARDWARE CHECK LIST		
DESCRIPTION	VISUAL DESCRIPTION	QTY
KNOB		2
HINGE PIN		4
HANDLE PLATE		2
KEYHOLE PLATE		1
ESCUTCHEON		2
HANDLE		2

DETAIL VIEWS

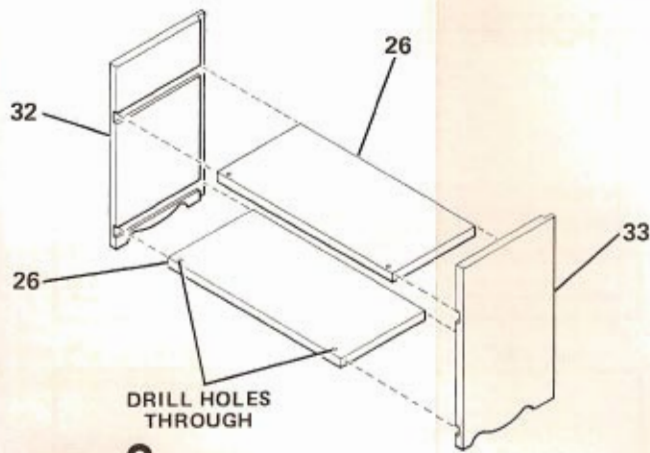

DETAIL A

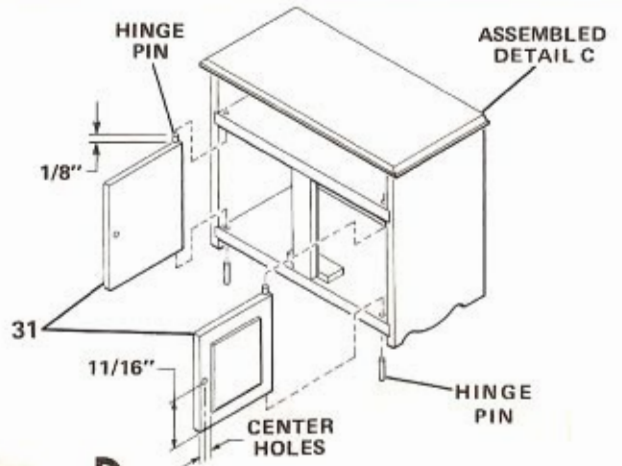

DETAIL D

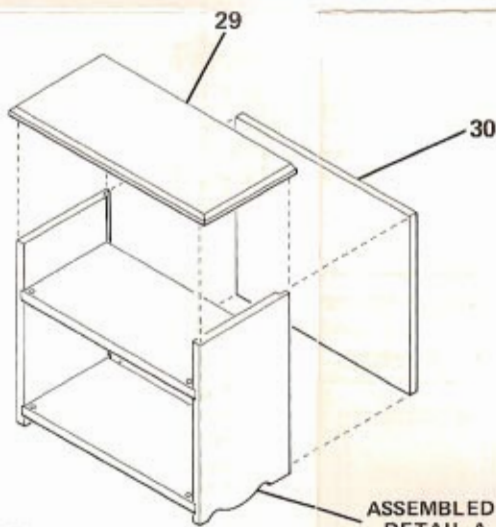

DETAIL B

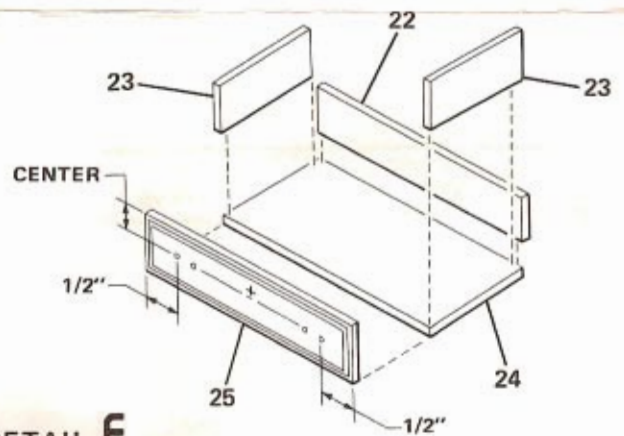

DETAIL E

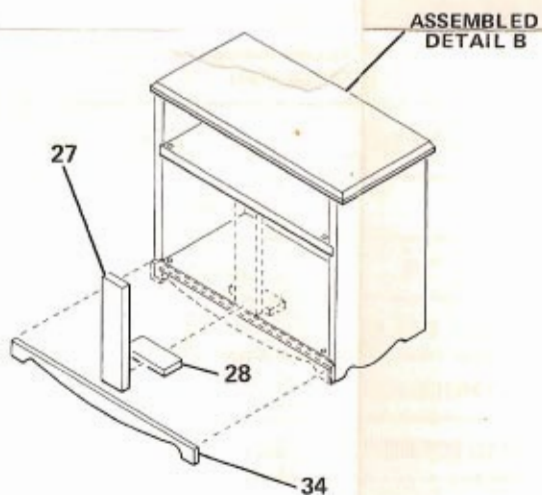

DETAIL C

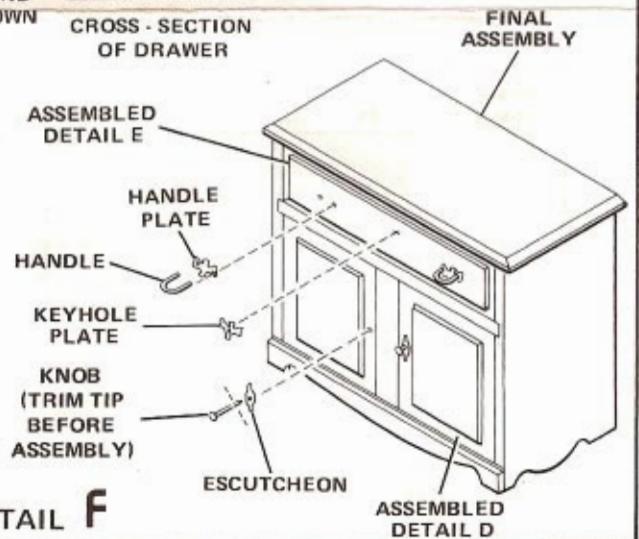
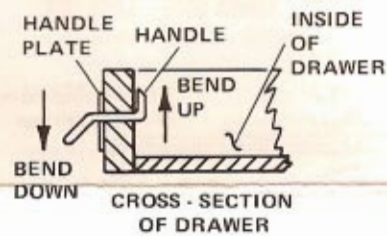

DETAIL F

ASSEMBLY

A. Before starting to assemble your kit, study all illustrations and instructions carefully. Be certain you understand each step before proceeding to the next one.

B. Follow the sequence of steps in the order they are presented. **Do not** skip steps or take any short cuts.

C. Refer to **ALIGNMENT** (page 5) for the pattern to be used to align the frame for gluing. When gluing parts together, use a flat toothpick or similar tool to apply a small amount of glue to the parts to be joined. Remove any excess glue promptly with a damp cloth. **Remember to let each glued assembly dry thoroughly before adding the next part.**

D. The Professional Finishing Kit, X-ACTO No. 43801, will produce the authentic mahogany finish of this period and contains a **matching tinted glue**, which is recommended for assembly of this kit. The **tinted glue** is of furniture grade quality, equivalent to that used by professional cabinet makers, and its use will avoid the appearance of a glue line at each joint.

E. Begin assembly of the **frame** (see **DETAIL A**, page 3) as follows:

1. Note the location of the hinge pin holes in the shelves (part no. 26). In one shelf, extend the hinge pin holes through the material using a straight pin or artist's push pin. This will be used as the bottom shelf.

2. Glue two shelves (part no. 26) into the grooves in the sides (part no.'s 32 and 33). **Make sure that the hinge pin holes are toward the front of the frame and the shelf with the through-holes at the bottom.**

3. Place the frame face down on the alignment pattern (see **ALIGNMENT**, page 5) and position the back (part no. 30) in place without gluing. This will serve to square off the frame and keep the parts in alignment. Use clamps or rubber bands to hold the parts together until the glue sets.

F. Continue assembly of the frame (see **DETAIL B**, page 3) as follows:

1. Glue the back (part no. 30) in place, as shown.
2. Glue the top (part no. 29) to top edges of the sides and back. Make sure that the rear edge of the top is flush with the edge of the back and that the top is centered over the sides.

G. Complete assembly of the frame (see **DETAIL C**, page 3) as follows:

1. Temporarily place the two doors (part no. 31) in position between the shelves and center the door separator (part no. 27) between the doors. Mark the position, then glue the door separator between the shelves.
3. Glue the door jamb (part no. 28) in position behind the door separator (part no. 27), as shown.
4. Glue the bottom molding (part no. 34) in place, as shown.

H. Install the doors (see **DETAIL D**, page 3) as follows:

1. Insert one hinge pin in top of door, as shown. Push pin in hole as far as it will go. Trim pin 1/8 inch above door using end snip pliers or diagonal cutters.

2. Using the dimensions shown, make a hole in each door with a straight pin or artist's push pin. Hardware will be installed in each hole in a later step.

3. Install door by angling door and inserting top hinge pin in hole in bottom of the top shelf (part no. 26). Position door over through-hole in bottom shelf (part no. 26) and insert lower hinge pin through shelf from bottom. Press in pin as far as it will go, then cut off excess. Repeat procedure for second door.

4. The doors should now swing freely on the hinge pins.

I. Assemble **drawer** (see **DETAIL E**, page 3) as follows:

1. Glue the drawer back (part no. 22) and the two sides (part no. 23) to the drawer bottom (part no. 24).

2. Position a handle plate at the locations shown on the drawer front (part no. 25) and mark the positions of the holes with a straight pin or artist's push pin.

3. Using the straight pin or push pin, make through-holes at each of the marked locations. Hardware will be installed in these holes in a later step.

4. Glue the drawer front (part no. 25) to the front edges of the sides (part no. 23) and bottom (part no. 24).

J. You have now completed assembly of your furniture, except for the installation of hardware. Now refer to **FINAL FINISHING**, to complete the piece.

NOTE: For authenticity, when finishing drawer, finish only the drawer front.

K. After **FINAL FINISHING** has been accomplished, install **brass hardware** (see **DETAIL F**, page 3) as follows:

1. Apply a small amount of glue to the back of an escutcheon.
2. Insert a knob through the hole in the escutcheon and press into the hole in the door, as shown. Remember that the pointed tip of the knob must be trimmed off before inserting it into the door.
3. Repeat procedure for the other door.
4. Apply a small amount of glue to the back of a handle plate.
5. Insert a handle through the holes in the handle plate and press into holes through the drawer, as shown. Bend up the ends of the handle together at the rear of the drawer front to hold it in place and bend down front of handles. Repeat procedure for the other drawer handle and plate.
6. Apply a small amount of glue to the back of a keyhole plate and attach to the drawer front as shown.

L. This completes your furniture. With the drawer in place in the cabinet and the brass hardware installed, your piece should look like that shown in **DETAIL F** (page 3).

FINAL FINISHING

In order to ensure that your piece is stained and highlighted in the tones of the period in which the original furniture was produced, we recommend that **X-ACTO Professional Finishing Kit, No. 43801** be used. The following method is used by professional furniture makers, and, if done properly, will result in museum quality.

A. After assembly is completed and the glue has set, **lightly** sand all joint areas to remove excess glue, using 220 grit sandpaper or finer. Moisten a cloth slightly and rub the dampened cloth over the entire wood surface to raise the grain. When all signs of moisture have gone from the wood, resand using a 320 to 400 grit sandpaper.

B. With a small brush, apply a light sealer coat to all edges and end grains. Use the side of the brush rather than the tip, in a wiping motion, so that the sealer does not touch other surfaces. Sealing the edge and end grains will prevent the subsequent stains from penetrating these areas as deeply, resulting in a more uniform stain on all parts.

NOTE: If the X-ACTO Finishing Kit (which contains a high quality sealer) is not used, thinned varnish or lacquer can be used for this purpose.

C. To match the color of furniture of this period apply **X-ACTO Base Stain** or mahogany or cherry stain of your choice with a brush or cloth over the entire wood surface. Immediately wipe off all excess stain leaving an even color on the surface. Allow to dry.

D. Apply a thin coat of **X-ACTO Sealer** or any commercial wood sealer over the base stain. This can be applied with either a brush or with the **X-ACTO Power Sprayer**. Make sure there are no drip marks present. Allow the sealer to dry for at least 6 hours.

X-ACTO POWER SPRAYER No. 43561 can be used to apply sealer, top coat, and paints for outstanding results. This spray ensures application of an even coat, especially on intricate and flat surfaces, and it is highly recommended for finishing your furniture.

E. Lightly go over all surfaces with Grade 000 steel wool until they are smooth to the touch.

F. "**Highlighting**" is a technique of creating light and dark areas and is accomplished by applying the **X-ACTO Glaze Stain** or any commercial glaze stain of your choice (Van Dyck Brown is the color recommended) and then toning by rubbing off the glaze in certain areas, exposing the base stain. In order to "highlight", apply a dark glaze with a brush or rag over the entire piece of furniture. As soon as you have applied this glaze, wipe off the excess. Blend tones of base color and glaze stain by using a piece of soft cloth. There should never be a sharp line of dark color to light color, but rather a smooth blending effect. Lighten the middle surface of the wood, but do not lighten the entire surface. The "**highlighting**" technique will produce museum quality miniature furniture.

G. After the glaze stain has dried for 24 hours, thoroughly and briskly wipe all surfaces with a clean cloth until you are satisfied with the appearance. Apply the **X-ACTO Top Coat** or a coat of lacquer or varnish, with a brush, an airbrush, or with the **X-ACTO Power Sprayer**. Apply two or more top coats with light buffing between coats using Grade 000 steel wool. After each steel wool rubbing make sure all steel wool "dust" is removed thoroughly. (Continue with **ASSEMBLY** starting with paragraph K).

